IC Bus® CE Series

Operation and Maintenance Manual

IC Bus, LLC

2701 Navistar Drive, Lisle, IL 60532 USA

IMPORTANT

The information, specifications, and illustrations contained in this manual are based on data that was current at the time of publication. IC Bus, LLC reserves the right to make changes and/or improvements at any time without notification, liability, or without applying those changes or improvements to vehicles previously manufactured and/or sold.

NOTICE

Be advised that this motor vehicle may be equipped with computer / recording devices. Their function is to allow an authorized individual to download data or information relating to the operation or performance of this vehicle.

The stored data or information may be neither downloaded nor retrieved except by the vehicle's registered owner, or, in the alternative, by another individual or entity authorized by the registered owner (e.g., IC Bus® dealer) who may need this data or information to properly service or diagnose this vehicle for repair or following an accident.

Any access to this information without the owner's consent may be in violation of law and may subject that person or entity to criminal penalties.

CALIFORNIA

Proposition 65 Warning



WARNING Breathing diesel engine exhaust exposes you to chemicals known to the State of California to cause cancer and birth defects or other reproductive harm.

- Always start and operate the engine in a well-ventilated area
- If in an enclosed area, vent the exhaust to the outside.
- Do not modify or tamper with the exhaust system.
- Do not idle the engine except as necessary.

For more information go to www.P65warnings.ca.gov/diesel

Battery posts, terminals and other related accessories contain lead and lead compounds, chemicals known to the State of California to cause cancer and birth defects or other reproductive harm.

Wash hands after handling.

IMPORTANT

It is important that the applicable vehicle identification number (VIN), engine serial number and or component feature codes are recorded. These numbers are required to obtain pertinent information for this vehicle or engine.

VEHICLE IDENTIFICATION NUMBER (VIN)

--

CUSTOMER ASSISTANCE CENTER

1-800-44-TRUCK (1-800-448-7825)

ENGINE

Feature Code: Serial Number:

--	--

Navistar, Inc.

2701 Navistar Drive
Lisle, IL 60532 USA
www.navistar.com

FRONT AXLE

Feature Code: Serial Number:

--	--

IC Bus, LLC

2701 Navistar Drive
Lisle, IL 60532 USA
www.navistar.com

REAR AXLE

Feature Code: Serial Number:

--	--

TRANSMISSION

Feature Code: Serial Number:

--	--

TRANSFER CASE

Feature Code: Serial Number:

--	--

Summary of Changes

Section	Description	Revision Level
Section 3 — Instrumentation	Electronic Stability Control (ESC) Information	2
Section 9 — Operations	ESC Information	2
Manual	Proposition 65 Warning Update	3
Section 6 — Passenger Control	Emergency Exit Window Information	3
Section 6 — Passenger Control	Vandal Locks	3
Section 3 — Instrumentation	Vehicle Telematics Information	4
Section 13 — Maintenance Instructions	Parking Brake Burnish Procedure	4

Section 1 – Introduction

Preface.....1
 Cautions / Warnings / Notes.....1
 Vehicle Identification.....1
 Assistance Guide.....2
 Component Code Numbers.....2
 Line Set Ticket.....2
 Vehicle Storage Instructions.....3
 Storage Duration – One Month or Less.....3
 Storage Duration–Over One Month4
 Diesel Exhaust Fluid (DEF) Storage.....4
 Reporting Safety Defects.....5
 U.S. Registered Vehicles.....5
 Canadian Registered Vehicles.....5
 Safety Recalls and Authorized Field Changes.....5
 Exterior Noise Emissions.....5
 Noise Emissions Warranty.....6
 Tampering with Noise Control System Prohibited.....6
 Emission Control Systems.....7
 HD-OBD Foreword.....7
 Supplemental Federal Emission Control System
 Warranty.....7

Section 2 – Vehicle Inspection Guide

Introduction.....9
 Inspection Check Lists.....13
 Underhood and Fluid Checks.....16

Section 3 – Instrumentation

Instrument Panel Gauge Cluster.....23

Warning Indicators.....25
 Instrument Panel Gauge Cluster.....28
 Direct Drive Warning Indicators.....29
 Integral Digital Display.....30
 Integral Digital Display Detailed Information.....33
 Outside Temperature and Compass Displays (Optional)...45
 Outside Temperature Reading.....46
 Optional Instrument Panel Gauge Cluster Compass
 Calibration Procedure.....46
 Compass Declination Zone Set Procedure.....47
 Compass Directional Calibration Procedure.....50
 User Switches.....52
 Instrument Panel Gauge Audible Alarms.....53
 Vehicle Telematics (If Equipped).....55
 Overview.....55
 Telematics Module (If Equipped).....55

Section 4 – Driver Controls

Windshield Wiper / Washer System.....57
 Wiper Blade Speed.....57
 Windshield Wiper Speed Control.....57
 Windshield Washer.....57
 Turn Signal.....58
 Steering Wheel and Column.....58
 Steering Wheel Controls.....58
 Steering Wheel Controls (Optional).....59
 Horn.....59
 Steering Wheel Controls (Optional).....59
 Cruise Control.....60
 Basic Functions of Steering Wheel Controls.....60
 Operational Procedures.....60

Table of Contents

Throttle.....	61
Stationary Variable Speed Control (12VXT).....	61
Stationary Pre-Set Speed Control (12VXU).....	61
Mobile Variable Speed Control (12VXV).....	62
Adjustable Tilt Steering Column.....	62
Left Console Switch Panel.....	63
Rocker Switches and Their Functions.....	63
Power Outlet.....	66
Transmission, Parking Brake, and Ignition Switch Panel.....	67
Right Console Switch Panel.....	69
Rocker Switches and Their Functions.....	69
Cruise Control.....	71
Operation.....	71
Mirror Adjustment.....	72

Section 5 – Lights

Headlight Switch and Panel Lighting Control.....	75
Headlight Switch.....	75
Automatic Headlights.....	75
Panel Lighting Control.....	75
Interior (Dome) Lights.....	75
Hazard Warning Light Switch.....	76
Turn Signal Switch.....	76
Signaling for a Turn.....	76
Lane Change.....	77
HIGH / LOW Beam.....	77
Strobe Light.....	78
Exterior Lamp Check.....	78
Switch Location.....	78
Function.....	78
Activation.....	78

Deactivation.....	78
-------------------	----

Section 6 – Passenger Control

Door Opening / Closing.....	79
Opening / Closing.....	79
Two-Position Door Switch.....	79
Three-Position Door Switch.....	80
Opening the Entrance Door.....	80
Opening the Entrance Door Manually.....	80
Electric-Actuated Door.....	80
Air-Actuated Door.....	81
Traffic Warning System.....	81
Electronic Safety Messages.....	81
Eight-Lamp AMBER and RED Warning Lights.....	81
Optional Rocker Switches.....	82
WIG WAG Warning System.....	83
Flashing Stop Arm.....	83
Crossing Gate.....	84
Driver Visual Warning Lights and Indicators.....	84
Audible Warning Buzzer.....	84
Post-Trip Inspection (No Student Left Behind).....	85
System Purpose.....	85
System Function.....	85
System Activation.....	85
System Deactivation.....	85
Snooze Mode.....	86
BUS-SCAN® 100 System.....	86
Unloading Students With Engine OFF.....	87
Wheelchair Lift Operation.....	87
Wheelchair Lift Interlocks – Extending.....	87
Wheelchair Lift Interlocks–Retracting and Stowing.....	88

Wheelchair Lift Alarm	88
Emergency Exits.....	88
Emergency Door.....	89
Emergency Exit Windows.....	89
Horizontal Emergency Exit Window.....	89
Vertical Emergency Exit Window.....	90
Roof Vent / Hatch.....	91
Vandal Locks.....	91
Vandal Locks with Starter Interlock (If Equipped).....	91
Entrance Door Lock (If Equipped).....	92

Section 7 – Seating and Safety Restraints

Driver Seat Adjustment.....	93
Seat Height Adjustment.....	94
Optional Air Suspension Seat.....	95
Driver Seat Belts.....	96
Driver’s Adjustable Lap and Shoulder (Three-Point) Belt.....	96
Seat Belt Tether.....	97
Tether Adjuster Procedure.....	97
Adjusting the Length of the Tether.....	98
Care of Seat Belts.....	98
Inspection of Seat Belts.....	99
Seat Belt Cutter.....	99
Passenger Seat Belts.....	100
Passenger Two-Point Seat Belt (Lap Belts).....	101
Passenger Three-Point Seat Belts (Optional).....	101
Buckling Up.....	101
Unbuckling.....	103
39-Inch Flex Seat.....	104
Integrated Child Restraint Seats (Optional).....	104

CE White Integrated Child Restraint Seats (Optional).....	107
Child Restraint Anchorage Systems (Optional).....	109
Location and Use of Lower Latch Anchors.....	110
Location of the Tether Anchor (Optional).....	110
IMMI® Seats Tether Installation.....	111
Location and Use of Tether Anchors (BTI Bus Seats).....	111
Installing Tether.....	111
Location and Use of Tether Anchors (SafeGuard® XChange Bus Seats).....	111
Cushion Release Latch.....	112
Track Seat Mounting Seat Type Specific.....	113

Section 8 – Climate Controls

Heater System.....	117
Driver Heater.....	117
Auxiliary Heaters.....	118
Defrost Operating Instructions.....	118
Auxiliary Fuel-Fired Heater System (Optional).....	118
Introduction.....	118
Description.....	119
Operation.....	119
Heater Control Switch.....	120
Heating Mode.....	120
Switching-Off Sequence.....	121
Air Conditioning.....	121
Integrated Air Conditioning System (IC Air).....	121
Circulation Fans.....	122
Heater Booster Pump.....	122
Heater Cutoff Valve.....	123

Table of Contents

Section 9 – Operation

Starting Procedures.....	125	Cold Weather Operation.....	142
Starting the Engine.....	125	Instructions.....	142
Automatic Transmission Starter Interlock.....	126	Engine Idling.....	143
After the Engine Starts.....	127	Winter Fronts.....	143
Engine Features.....	127	Hot Weather Operation.....	143
Fuel.....	128	Turning OFF the Engine.....	144
Ultra-Low Sulfur Diesel Fuel Requirements.....	128	Brakes.....	144
Unacceptable Fuel Blends.....	128	Downhill Operation.....	144
Hazards of Diesel Fuel / Gasoline Blends.....	128	Warning Indicators.....	144
Additional Unsafe Practices.....	129	SmartTrac™ Hydraulic Brake Booster System (If Equipped).....	145
Fuel and Lubricant Additives.....	129	Split-System Feature.....	146
Fueling Procedures.....	129	Manual Foot Operated Parking Brake System with Hydraulic Brakes.....	146
Fueling Precautions.....	130	Air Brakes.....	148
Reserve Fuel.....	130	Air Disc Brakes (0004JBZ, 0004JCC, 0004WEY, 0004WEZ).....	148
Restarting After Running Out of Fuel.....	130	Using Air Brakes.....	149
Engine Brake, Exhaust Brake, or Retarder (Optional).....	130	Using the Air Parking Brake.....	149
Engine and Exhaust Brake Systems Operation.....	130	Parking Brake Indicator Light.....	150
Operational Modes.....	131	Parking Brake / Wheelchair Lift Interlock and Alarm.....	151
Exhaust Aftertreatment.....	131	Wheelchair Lift Extension Operation.....	151
Selective Catalytic Reduction System (If Equipped).....	131	Parking Brake / Wheelchair Lift Interlock–Retracting and Stowing Operation.....	151
Introduction.....	131	Parking Brake / Wheelchair Lift (Optional) Alarm.....	151
Diesel Exhaust Fluid.....	131	Antilock Braking System (ABS).....	152
DEF Tank.....	132	Antilock Driving Tips.....	153
Low DEF Level.....	132	ABS Self-Check.....	153
DEF Contamination or SCR System Fault.....	134	Pedal Adjustment Switch (If Equipped).....	154
Exhaust Diesel Particulate Filter Regeneration.....	138	Traction Control.....	154
Parked Regeneration Procedure.....	141	Driver Assist Systems.....	155
Regeneration Inhibit Switch.....	141	Bendix® Wingman® Advanced™ Collision Warning System.....	155
Two-Position Regeneration Inhibit Switch.....	142		
Three-Position Regeneration Inhibit Switch.....	142		
Restarting After Running Out of Fuel.....	142		

Bendix® Wingman® Fusion™ System.....157
 Stability Control Systems – Bendix® Electronic Stability Program (ESP).....159
 International® Ride Optimized Suspension (IROS) (If Equipped).....160
 Automatic Transmission Operation.....160
 Standard Allison 1000 PTS Transmission.....160
 Allison Transmission Mechanical Lever Shifters.....161
 Allison Generation IV T-Bar Gearshift Control.....162
 Allison Generation IV Push-Button Shift Selector.....163
 Parking the Vehicle.....164
 Eaton® Procision™ Transmission.....164
 Parking the Bus With Transmission Shift / Wheelchair Lift Interlocks.....166
 Wheelchair Lift Extension Operation.....166
 Starting Bus in Motion.....166
 Starting Bus in Motion With Transmission Shift / Wheelchair Lift Interlocks.....167
 Retracting and Stowing Operation.....167
 Backup Alarms.....167
 Economy Mode.....167
 Automatic Transmission Operating Temperatures.....168

Section 10 – Roadside Emergencies

Hazard Warning Switch.....169
 Emergency Equipment (Recommended On-Board).....169
 Fire Extinguisher.....169
 First Aid Kit.....170
 Body Fluid Cleanup Kit.....170
 Reflective Triangle.....171
 Fuse / Circuit Breaker Charts.....171

Body Fuse / Circuit Breaker Panel.....174
 Tilt Hood.....178
 Raising the Hood.....178
 Lowering the Hood.....179
 Emergency Starting Using Jumper Cables.....179
 Towing Instructions.....180
 Towing Preparation: Air Parking Brakes.....181
 Towing Vehicle With Front Wheels Suspended.....181
 Towing Vehicles With Rear Wheels Suspended.....181

Section 11 – Cleaning

Surface Cleaning.....183
 General Cleaning, All Surface Types.....183
 ABS / Plastic.....184
 Glass.....184
 Interior.....184
 Interior Light Bar Cleaning.....184
 Upholstery Care.....184
 Flooring.....185
 Exterior.....185
 Waxing or Polishing Vehicles.....186
 Crossing Arm Cleaning.....186

Section 12 – Maintenance

Preface.....187
 Maintenance Guidelines.....187
 Supporting Your Vehicle for Service.....189
 Pre-Trip and Post-Trip Inspections.....189
 Chassis Lubrication.....189
 Engine Compartment Fluid Check Points.....190

Table of Contents

Air-Operated Passenger Door Adjustments.....	191	Terminal Inspection–Cleaning–Corrosion Protection... ..	202
Door Opening and Closing Speed Adjustment Points... ..	191	Accessory Feed Connections.....	202
Pressure Regulator Adjustment.....	191	Engine.....	203
Opening Speed Adjustment.....	192	General.....	203
Closing Speed Adjustment.....	192	Engine Fluids and Contaminated Material.....	203
Electrically Actuated Entrance Door Adjustment.....	192	Scheduled Maintenance.....	204
Axles.....	192	Air Induction System.....	204
Front Axle – Inspection and Lubrication.....	192	Air Cleaner Element Service.....	204
Front Axle – Normal Maintenance.....	193	Air Restriction Gauge Service	206
Front Axle – Alignment.....	193	Chassis-Mounted Charge Air Cooler and Radiator	
Rear Axle – Inspection and Lubrication.....	194	Core Inspection and Cleaning.....	208
Body.....	194	Cooling System.....	208
Brakes.....	194	Gravity-Fill Coolant Method.....	208
General Information.....	194	Coolant and Optional Coolant Filter.....	211
Air Brakes.....	195	Coolant Concentration / Freeze Point.....	212
Brake Inspection and Adjustment.....	195	Fan Clutch.....	212
Air Dryer.....	197	Heater and Coolant Hose Inspection and	
Air Dryer Desiccant Replacement.....	197	Replacement Guide.....	212
Air Dryer Purge Valve.....	198	Frame and Optional Tow Hooks.....	213
Air Dryer Heater.....	198	Fuel System.....	214
Air Reservoir / Tanks Moisture Draining.....	198	Fuel Tank Draining and Cleaning.....	214
SmartTrac™ Hydraulic Brakes (If Equipped).....	199	Heater System.....	215
Brake Inspection and Adjustment.....	199	Integrated Air Conditioning (IC Air) System.....	215
Fluid Precautions.....	199	Noise Emissions – Maintenance, Use and Repair.....	215
Brake Lines, Hoses, and Fittings.....	199	Instructions for Proper Maintenance.....	215
Hydraulic Brakes.....	200	Air Intake System.....	215
Brake Fluid Level (SmartTrac™ System).....	200	Body.....	215
SmartTrac™ Hydraulic Brakes - Fluid Precautions... ..	201	Cooling System.....	215
Driveline Parking Brake.....	201	Engine Noise Shields / Blankets.....	216
Chassis Inspection.....	201	Exhaust System.....	216
Electrical.....	202	Maintenance Record – Noise Control.....	217
Alternator–Starter–Battery Test.....	202	Drive Shaft.....	218

Suspension (Air and Steel Springs).....	218
Steering.....	218
General.....	218
Tightening Steering Intermediate Shaft Joint Bolts.....	219
Lubrication Points.....	219
Power Steering.....	220
DEF Tank Filling.....	221
Exhaust Diesel Particulate Filter (DPF).....	222
Regeneration.....	222
Cleaning.....	222
Transmission.....	222
Transmission Fluid Level.....	222
Tires.....	223
Tire Warnings.....	223
Tire Maintenance.....	224
Checking Inflation.....	224
Underinflation.....	225
Inspection.....	225
Loads.....	225
Dual Tires Matching.....	226
Dual Tires Mixing.....	226
Rotation.....	226
Rotation Is Advisable.....	226
Tire Replacement.....	227
Wheel and Tire Balancing.....	227
Wear.....	227
Irregular Wear.....	227
Use of Tire Chains.....	228
Wheels.....	228
Wheel and Wheel Nut Maintenance and Installation....	228

Wheel Nut Torque Maintenance.....	229
Hub-Piloted Wheel Installation Procedures.....	229
Windshield Wiper.....	231
Wiper Blade Assembly Replacement.....	231
Wiper Arm Removal / Replacement.....	231
Removal.....	232
Installation.....	232

Section 13 – Maintenance Intervals and Specifications

Maintenance Intervals.....	233
Unit Refill Capacities.....	243
Air Conditioner Refrigerant.....	243
Cooling System Refill Capacities.....	243
Diesel Exhaust Fluid Tank.....	244
Engine Crankcase.....	244
Tire and Rim Combinations.....	245
Lubricant and Sealer Specifications.....	246
Torque Specification Charts.....	254
Filter List.....	256

Section 14 – Customer Assistance

Service Information.....	257
Navistar, Inc., Warranty Program.....	257

Section 15 – Index

Index.....	259
------------	-----

Table of Contents

SECTION 1 — INTRODUCTION

Preface

All IC Bus® vehicles are engineered and manufactured to provide economical and trouble-free service. It is the owner's responsibility to ensure the bus receives proper care and maintenance.

Making modifications to various parts, components and systems of your bus can adversely affect the quality and reliability of your vehicle. IC Bus does not recommend making modifications to this bus.

This manual provides information needed to understand the operation of your bus and its safety features. It also contains information necessary for the proper operation and maintenance of various bus body and chassis systems.

Do not operate this bus until you are completely familiar with the contents of this manual. Keep this manual in your bus for reference. If you sell the bus, ensure this manual stays with it.

Optional Features. This manual describes many optional features that may not be installed in this vehicle.

Cautions / Warnings / Notes

Cautions, Warnings and Notes are included throughout this manual.



CAUTION

Cautions advise you of the proper care to be taken to prevent damage to your vehicle or property.



WARNING

Warnings advise you of hazards, the consequences, and what to do to prevent them, not only to prevent damage to your vehicle or property, but to help prevent situations and occurrences that could result in personal injury or death.

NOTE: Notes indicate an operation, procedure or instruction that is important for correct service.

Vehicle Identification

It is important that you record the Vehicle Identification Number (VIN), Component Code Numbers, and Serial Numbers. Use these numbers to obtain parts and information for your bus.

NOTE: The following illustration represents a typical VIN tag. The actual VIN tag may vary.

Introduction

821280

MANUFACTURED BY
IC CORPORATION

DATE OF MANUFACTURE 5 MO. 03 YR.

GVWR 12474 KGS(27500 LBS)
GAWR FRONT 4536 KGS(10000 LBS) GAWR REAR 7938 KGS(17500 LBS)
WITH 265/75R22.5G TIRES 14 PLY WITH 245/75R22.5G TIRES 14 PLY
AT 759 KPa(110 PSI) COLD AT 759 KPa(110 PSI) COLD
RIMS 22.5X7.50 RIMS 22.5X7.50

THIS VEHICLE CONFORMS TO ALL APPLICABLE FEDERAL
MOTOR VEHICLE SAFETY STANDARDS IN EFFECT ON
THE DATE OF MANUFACTURE SHOWN ABOVE.

VEHICLE IDENTIFICATION NO. 4DRBRAAPX3A953275

VEHICLE TYPE 452308001 SCHOOL BUS BODY# 953275MD

ICB100112

Assistance Guide

IC Bus believes that every customer is entitled to the best service, both from the product itself and from the firm who sells and services that product.

If for any reason, you do not feel you are receiving these services for the operation of your vehicle or the sales transaction, return to your selling dealer to correct these matters. If the matter is not resolved at that time:

- Contact a member of management at the Dealership to discuss the details of the difficulty. In most cases a problem can be resolved to your satisfaction by the owner or manager.

When parts are required, always provide the Component Code Number, vehicle model and Vehicle Identification Number. Ask your salesperson to assist you in obtaining this information.

For more information not given in this manual, or if you require services of trained service personnel, we urge you to contact a nearby IC Bus® or International® dealer or phone 1-800-44-TRUCK (87825) for assistance.

Component Code Numbers

Code numbers are the basis for identifying the components used on your IC Bus® vehicle. They are used by sales personnel to order the bus, by manufacturing to build it, and by parts to service the bus. Many items in this manual are identified by codes.

Code numbers are a combination of numbers and / or letters. These codes are listed on the Vehicle Line Set Ticket which is sometimes called the Vehicle Specification Card or Code Sheet.

Line Set Ticket

Each vehicle has a Line Set Ticket (Code Sheet) which lists the identification code numbers of components used to build the vehicle.

A copy of the Line Set Ticket is included in the literature provided with the vehicle. When replacement parts are required, use this copy to positively identify International® or IC Bus® vehicle components to ensure you get the correct parts.

Vehicle Storage Instructions

When a vehicle is not used for an extended period of time, precautions must be taken to prevent deterioration of vehicle components. Vehicles that are out of service for extended periods of time can experience corrosion and other undesirable effects. Drive vehicle monthly to exercise the brakes, driveline and steering. Run the vehicle long enough for the engine to reach operating temperature.

NOTE: Losses occurring to a unit while it is in storage will not be considered for warranty reimbursement.

Storage Duration – One Month or Less

1. Wash vehicles as necessary. Always wash vehicles that have been exposed to road salt.

NOTE: Washing Instructions - Wash the vehicle with warm water and mild soap, then wipe wet surfaces with a chamois or soft cloth. DO NOT use hot water or strong soaps or detergents. DO NOT wash the vehicle in direct sun, or when the sheet metal is hot to the touch. This will streak the finish. DO NOT wipe dirt off dry surfaces, as this will scratch the finish.

NOTE: When vehicles are stored outside, particularly in coastal areas (salt water and high humidity atmosphere) or other areas of corrosive environment, paint and bright metal may require frequent washing and waxing to prevent deterioration. Determining washing frequency is the customer's responsibility.

NOTE: For vehicles exposed to ultraviolet rays of the sun, apply a coating of Bon Ami® soap, or similar product, to the inside surfaces of the windshield and windows, to shade the interior and prevent fading of the interior trim.

2. Inspect painted surfaces; touch up all exposed primed or raw metal areas to prevent rust.
3. Apply a thick coat of wax to prevent discoloration from the elements; wax all chrome and stainless steel metal parts.
4. Check the radiator coolant for proper level and adequate freeze protection (-20°F [-29°C] is standard for medium duty models and bus chassis; -40°F [-40°C] is standard for heavy duty models.)
5. Cover open ends of vertical exhaust stack(s).
6. Drain air brake reservoirs and close the drain cocks.
7. Lubricate all exposed transmission, auxiliary transmission, and Power Take Off (PTO) shift rails.
8. Check state-of-charge eye in batteries and re-charge if open circuit voltage is below 12.6 volts. Disconnect battery ground cables to prevent accidental starting, or parasitic electrical loads from discharging the battery.

Introduction

Storage Duration—Over One Month

Units in storage longer than one month should be driven until the engine reaches operating temperature:

1. Ensure all tires are inflated properly, remove vertical exhaust stack covers, and reconnect batteries.
2. Check all vehicle fluid levels and fill as required.
3. Start and run the vehicle at fast idle, until it reaches operating temperature. To remove surface charge from the battery, built up from previous start-ups and short idle periods, operate the heater and / or air conditioner, headlights, and other accessories for several minutes.
4. Turn OFF heater and / or air conditioner and any other accessories; shut OFF the headlights. Park the vehicle and shut OFF the engine.
5. Perform the procedure for **Storage Duration - One Month or Less**, if returning the vehicle to storage.

NOTE: After every 30 additional days of storage, perform Items 1 through 5.

Storage Facilities

1. Whenever possible, store vehicles indoors, protected from sunlight, in a dry, well ventilated area. If indoor storage is not available, select storage lots to eliminate conditions that cause deterioration.
2. Park away from transformers and / or electrical motors, because when the protective wax in tire

compound cracks, ozone in the air attacks the exposed areas.

3. Park away from trees, high weeds and / or grass to prevent damage from tree or weed sap, and to minimize bird and insect stains.
4. Park away from railroad tracks, paint shops, smoky industrial areas, and locations of possible road splash contact.
5. If a vehicle is parked on an incline, install wheel chocks.

Diesel Exhaust Fluid (DEF) Storage

Diesel Exhaust Fluid has a limited shelf life, both in the vehicle's diesel exhaust fluid (DEF) tank and in storage containers.

The following conditions are ideal for maintaining DEF quality and shelf life during prolonged transportation and storage:

- Storage temperature between 23°F and 77°F (-5°C and 25°C)
- Store in sealed containers to avoid contamination
- Avoid direct sunlight

Long term in vehicle storage (in excess of 6 months) is not recommended. If long term storage is necessary, periodic testing of the Diesel Exhaust Fluid is recommended to ensure proper DEF concentration.

Reporting Safety Defects

U.S. Registered Vehicles

If you believe that your vehicle has a defect that could cause a crash or could cause injury or death, you should immediately inform the National Highway Traffic Safety Administration (NHTSA) in addition to notifying Navistar, Inc. To notify Navistar, Inc., see the contact information listed in the front of the manual.

If NHTSA receives similar complaints, it may open an investigation and, if it finds that a safety defect exists in a group of vehicles, it may order a recall and remedy campaign. However, NHTSA cannot become involved in individual problems between you, your dealer, or Navistar.

To contact NHTSA, you may either call the Auto Safety Hotline toll-free at 1-800-424-9393 (or 202-366-0123 in Washington, D.C. area) or write to: NHTSA, U.S. Department of Transportation, Washington, D.C. 20590. You can also obtain other information about motor vehicle safety from the hotline.

Canadian Registered Vehicles

If you believe that your vehicle has a defect which could cause injury or death, to the operator, passengers or persons outside the vehicle, immediately inform Transport Canada in addition to notifying IC Bus.

To contact Transport Canada, you may call 800-333-0510. You can also write to: Transport Canada, Motor Vehicle Defect Investigation, 2780 Sheffield Road, Ottawa, Ontario K1G 3V9.

Safety Recalls and Authorized Field Changes

Safety Recalls and Authorized Field Changes are two campaigns that are used to notify owners of modifications that may involve their vehicle. If you receive such notification, PLEASE FOLLOW ALL INSTRUCTIONS PROVIDED IN THE CUSTOMER LETTER. If your vehicle is part of a Safety Recall campaign, the recall service procedure must be completed to ensure safe operation of your vehicle. As a vehicle owner, you must provide IC Bus® dealers with address corrections and changes to ensure that you receive all notifications. Please verify that your IC Bus® dealer has your correct address. Dealers also have a record of any outstanding campaigns that affect your vehicle.

Exterior Noise Emissions

Many operators and owners of the type of vehicles described herein are subject to *Federal Motor Carrier Safety Regulations and Noise Emission Requirements*. All owners and operators are urged to obtain a copy and comply with these regulations. Copies of these regulations can be purchased from:

Superintendent of Documents
U.S. Government Printing Office
Washington, D.C. 20401
<https://www.gpo.gov/>

Introduction

Noise Emissions Warranty

IC Bus warrants to the first person who purchases this vehicle for purposes other than resale and to each subsequent purchaser that this vehicle, as manufactured by Navistar, was designed, built, and equipped to conform at the time it left Navistar control with all applicable U.S. Environmental Protection Agency Noise Control Regulations.

This warranty covers this vehicle as designed, built, and equipped by IC Bus and is not limited to any particular part, component, or system of the vehicle manufactured by IC Bus. Defects in design, assembly, or in any part, component, or system of the vehicle as manufactured by IC Bus, which at the time it left IC Bus control, that cause noise emissions to exceed Federal standards are covered by this warranty for the life of the vehicle.

Tampering with Noise Control System Prohibited

Federal law prohibits the following acts or the causing thereof:

1. Removing or rendering inoperative by any person, other than for purposes of maintenance, repair, or replacement, of any device or element of design incorporated into any new vehicle for the purpose of noise control prior to its sale or delivery to the ultimate purchaser or while it is in use.
2. Using of the vehicle after such device or element of design has been removed or rendered inoperative by any person.

Among those acts presumed to constitute tampering are the acts listed as follows:

1. Air Intake System: removal of air cleaner, intake silencer, or piping.
2. Acoustical Shielding (Body): removal of wheel well splash shields, cab shields, or acoustical (underhood) insulation.
3. Cooling System: removal or rendering inoperative the fan clutch and / or removal of fan shrouds.
4. Engine and Driveline System: removal or rendering engine speed governor inoperative so as to allow engine speed to exceed manufacturer specifications, and / or removal of engine block shield, oil sump shield, or transmission enclosures.
5. Changes in hardware, software, calibration or programmable parameters that increase engine operating speed or horsepower other than those provided by IC Bus.
6. Exhaust System: removal or rendering inoperative exhaust system components, including muffler, resonator, exhaust aftertreatment components, or tailpipe.

NOTE: Refer to Section 12 – Maintenance Instructions for proper maintenance, use and repair of noise emission items.

Emission Control Systems

NOTE: Federal and California Emission system warranties are found in your Engine Operation and Maintenance Manual.

HD-OBD Foreword

Heavy Duty On-Board Diagnostics (HD-OBD) is a U.S. Government mandated standard for all 2013 and later Class 4 and above vehicles with a Gross Vehicle Weight Rating (GVWR) of 14,001 pounds or more. The HD-OBD system monitors the engine and aftertreatment systems to verify they are operating within emissions limits. If an emissions fault is logged, the Malfunction Indicator Lamp (MIL) will illuminate and one or more fault codes will be set.

The HD-OBD system operates similarly to previous power train control systems by storing fault codes and turning on the MIL. If the problem that caused the fault goes away, the code will clear and the MIL will go out after certain operating conditions have been met. This may take several times operating the vehicle.

Supplemental Federal Emission Control System Warranty

The United States Environmental Protection Agency adopted new heavy-duty Greenhouse Gas (GHG) vehicle regulations on 15 September 2011. This vehicle may be certified to the GHG regulations. For certified vehicles, additional GHG emissions control system warranty covers certain vehicle components. This Supplemental GHG Federal Emission Control System Warranty coverage for these vehicle components will be managed according to current Federal Emission Control System

Warranty process. The GHG emission control system warranty applies to the below listed vehicle components such that they meet the following two conditions:

1. The vehicle and / or GHG emission control system component is designed, built, and equipped so it conforms at the time of sale to the ultimate purchaser with the requirements of the GHG regulations and such component is an emission control and appears on the GHG vehicle emission certification label, and
2. The vehicle and / or GHG emission control system component is free from defects in materials and workmanship that cause the vehicle to fail to conform to the GHG requirements during the applicable supplemental warranty period.

GHG Emission Control System Warranty Period

The GHG emission control system warranty period begins on the date the new GHG certified vehicle is delivered to you. The period of coverage is the greater of the base mechanical warranty or:

- Five (5) years or 50,000 miles, whichever comes first, for spark-ignition and light heavy-duty diesel vehicles with GVWR below 19,500 pounds.
- Five (5) years or 100,000 miles, whichever comes first, for medium and heavy heavy-duty vehicles with GVWR equal to or greater than 19,500 pounds.
- Two (2) years or 24,000 miles, whichever comes first, for tires.

Introduction

Additional Components Covered

Applies to all certified models:

The GHG emission-related warranty covers the following components such that they meet the two conditions listed above: .

1. Hybrid system components (where applicable)
2. Components whose failure would increase a vehicle's evaporative emissions (for vehicles subject to evaporative emission standards)
3. Tires

Applies only to certain certified Fifth wheel equipped ProStar®, LoneStar®, TranStar®, DuraStar®, and 9900 models:

The GHG emission-related warranty covers:

1. Vehicle speed limiters
2. Idle shutdown systems
3. Fairings to the extent such emission-related components are included in the certified emission controls and are listed on the vehicle GHG certification label

The GHG emission-related warranty covers all components whose failure would increase a vehicle's emissions of air conditioning refrigerants for vehicles subject to air conditioning leakage standards.

Applies only to certified vehicles equipped with innovative technologies:

The GHG emission-related warranty covers components certified as innovative technologies which are part of the certified emission controls. Please contact your authorized International Dealer for further information.

Supplemental Federal Emission Control System Maintenance, Repair, and Replacement

Your vehicle may comply with the Greenhouse Gas (GHG) regulations adopted by the Environmental Protection Agency on 15 September 2011. As owner or operator of a GHG compliant vehicle, your vehicle and GHG emissions control system components should be properly maintained in good working order.

Repair and replacement of GHG emission control system components should be done to original vehicle manufacturers' specifications to ensure proper function of the vehicle. Tire replacement should be to tires with GHG emission performance as good, or better, than tires originally equipped on the vehicle. Consult with the tire manufacturer for tire specifications.

The United States Environmental Protection Agency allows limited modification of your vehicle and its GHG emission control system components. Please refer to applicable regulations for allowable and prohibited modifications.

SECTION 2 — VEHICLE INSPECTION GUIDE

Introduction

A pre-trip inspection, in accordance with Commercial Driver License (CDL) regulations, the Department of Transportation (DOT) and state regulations, is absolutely necessary before you can begin the first route of the day. The routine can vary from bus to bus, but it is essential to have a routine and stick to it. The following inspections may include checks that are in addition to the CDL requirements. If the pre-trip inspection reveals a problem, report it to the service department or a qualified technician so that it can be repaired before operating the vehicle.

After returning from your daily routes, you must complete a written inspection report in accordance with CDL regulations. Report any faults that you find, or any problems that occurred during your trip, to the service department so that they can be repaired before the next trip.

NOTE: Ensure your bus is in proper operating condition to keep the passengers safe.

NOTE: The driver's window cannot be unlocked from the outside.

NOTE: If the buzzers do not activate with the ignition turned ON and the emergency exits open, have the vehicle repaired before placing the vehicle in service.

NOTE: Ensure that every emergency exit door and release bar is not blocked.

NOTE: The following illustrations are for reference only and may slightly differ from the actual vehicle.

Vehicle Inspection Guide

CE Bus Front View

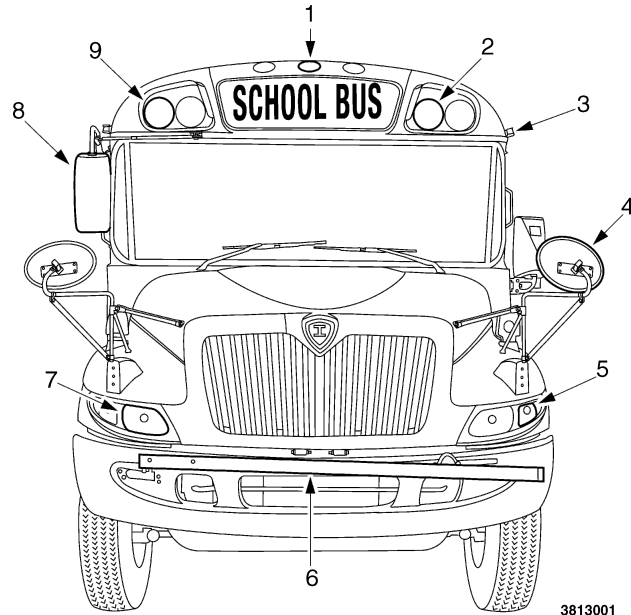

3813001

1. Identification lamp (3)
2. AMBER warning light (2)
3. Clearance lamp (2)
4. Cross view mirror (2)
5. Turn signal (2)
6. Crossing gate
7. Headlight (2)
8. Rearview mirror (2)
9. RED warning light (2)

CE Bus Rear View

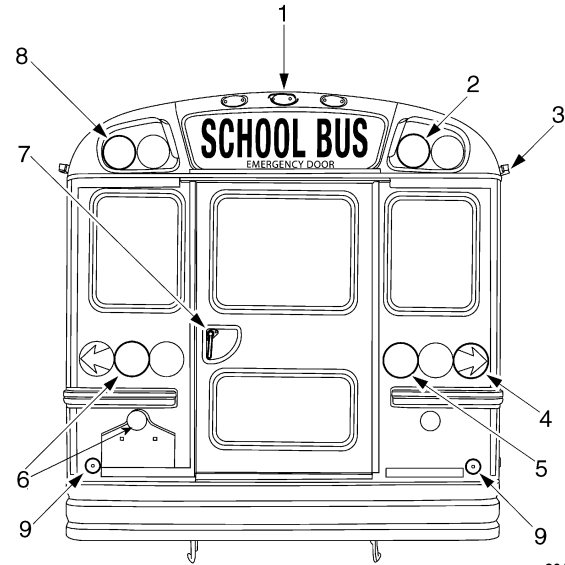

3813002

1. Identification lamp (3)
2. Amber warning light (2)
3. Clearance lamp (2)
4. Turn signals (2) (with or without arrows)
5. Backup light (2)
6. Stop light / tail light (2)
7. Emergency door handle
8. RED warning light (2)
9. Reflex reflector (2)

CE Bus Right View

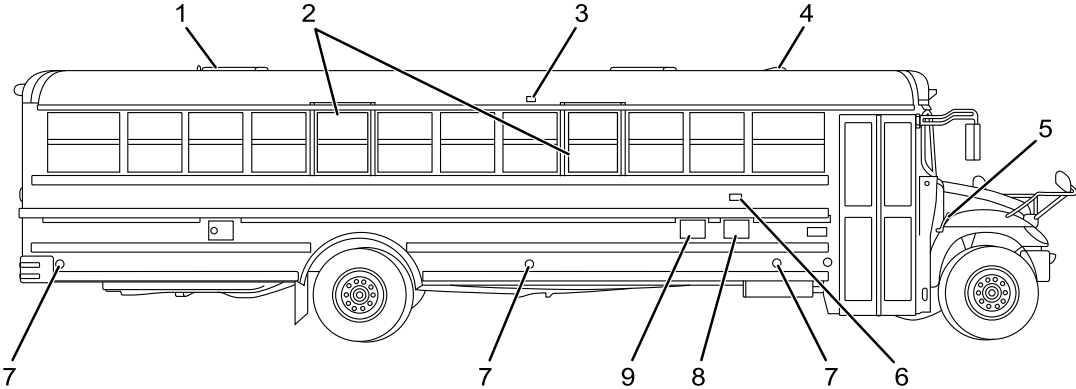

0000413625

- | | | |
|----------------------------------|----------------------------------|-------------------------------------|
| 1. Emergency roof vent / hatch | 4. Static vent | 7. Reflex reflector |
| 2. Emergency kickout window | 5. Hood latch | 8. DEF fill door (typical location) |
| 3. Side mounted turn signal lamp | 6. Side mounted turn signal lamp | 9. Fuel door (typical location) |

Vehicle Inspection Guide

CE Bus Left View

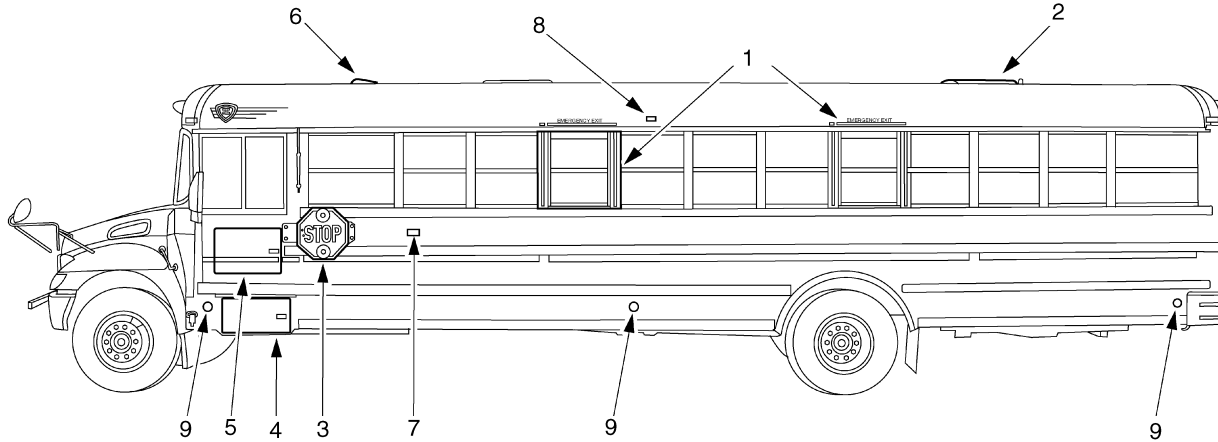



3813004

- | | | |
|--------------------------------|--|----------------------------------|
| 1. Emergency kickout window | 4. Battery compartment | 7. Side mounted turn signal lamp |
| 2. Emergency roof vent / hatch | 5. Electrical compartment access panel | 8. Intermediate side marker lamp |
| 3. Stop arm | 6. Static vent | 9. Reflex reflector |

Inspection Check Lists

Exterior Checks

Location	Description
<p style="text-align: center;"> WARNING</p> <p>To prevent personal injury and / or death, or damage to property, turn OFF engine and set the parking brake anytime you leave the vehicle. NEVER LEAVE THE VEHICLE UNATTENDED WITH ENGINE RUNNING.</p>	
Walk-Around Inspection	Look and listen for leaks and puddles as you walk up to the bus. Check for vandalism and loose items under the vehicle. Check the fuel door and the fuel tank cap. Review the results of the previous post-trip inspection with your supervisor or previous driver. Check all previously noted items to ensure that all requested repairs have been made.
Leaks	Check for signs of fluid leaks in the engine compartment. Also check for signs of drips on the ground under the engine.
Outside Mirrors	Ensure the outside view is not obstructed. Check the cross-view and rear-view mirrors for cleanliness. Also ensure the mirrors are intact and properly adjusted.
Battery	<p style="text-align: center;"> WARNING</p> <p>To prevent personal injury and / or death, or damage to property, keep lighted tobacco, flames, sparks or other ignition sources away from the batteries. Gas from the battery cells is flammable and can ignite and / or explode. This is particularly true when jumper cables are being used. In addition, inhaling the hydrogen gas produced by the normal operation of the battery could result in partial or permanent damage to the respiratory system.</p> <p>Check the batteries for loose wires or corrosion at the terminals to prevent possible battery or starting failure.</p>

Vehicle Inspection Guide

Exterior Checks (cont.)

Location	Description
Lights and Reflectors	Turn ON the exterior lamp check system to ensure all exterior lights are working. For operation of the system see Section – 5 Lights . Check the operation of the AMBER warning lights, RED warning lights, and hazard warning lights. If your bus has an exterior strobe light, test it as well. Inspect all reflectors, headlights, turn signals, and emergency flashers. Ensure they are clean, firmly attached, and without cracks or breaks.
Wheels and Tires	<p style="text-align: center;"> WARNING</p> <p style="text-align: center;">To prevent personal injury and / or death, or damage to property, if wheels or tires must be changed, obtain expert tire service help. Mounting and dismounting of tires should only be performed by qualified personnel using necessary safety procedures and equipment.</p> <p>Inspect all wheels and tires for any obvious defects, damage, or excessive tread wear. Check tires for the proper inflation. Check wheel or rim nuts for tightness and condition. If equipped with front oil type wheel bearings, check for proper oil level.</p>
Rear Axle and Wheel Bearings	Check for obvious leaking on outside or inside of wheel. Inspect axle flanges and wheel seals for leaks and loose mounting hardware, or broken items. Check lube level, if equipped with sight glass.

Front / Rear Suspension

Location	Description
 WARNING To prevent personal injury and / or death, or damage to property, do not operate vehicle if there is a loss of steering or suspension, which could result in a loss of vehicle control.	
Springs	Look for missing, broken or shifted leaves, or leaves that are in contact or nearly in contact with the tire, wheel, brake drum, brake chamber, frame or body.
Spring Mounts	Check the spring hangers, bolts, bushings, axle mounting U-bolts and nuts for cracks, breaks, wear, damage, tightness, and missing hardware. For proper torque, refer to the torque charts in the Maintenance section .
Shock Absorbers	Check for cracks, leaks, and missing or broken mounting bolts or bushings.

Brakes

Location	Description
Drum or Rotor and Brake Linings	Check to see that there are no cracks, dents or holes and no loose or missing bolts. Check to see that the brake linings, where visible, are not worn thin or contaminated by lubricant.
Hoses	Check for secure couplings and for cracked, worn or frayed hoses.
Chamber (Air Brakes Only)	Check to see that the brake chambers are not cracked or dented and that they are securely mounted.
Slack Adjuster (Air Brakes Only)	Check for broken, loose or missing parts: angle between push rod and adjuster arm should be approximately 90 degrees when the brakes are applied.
Air Wet Tank (Air Brakes Only)	Drain water daily.

Underhood and Fluid Checks



WARNING

To prevent personal injury and / or death, or damage to property, maintain adequate clearance between all parts of the exhaust system and all hoses, wires, and lines for engine cooling, brake system, fuel system, power steering system, and electrical system. Heat damage to hoses and wires may cause vehicle malfunction.



WARNING

To prevent personal injury and / or death from hot coolant or steam scalding, use the following procedure to remove the pressure cap from the deaeration tank:

- A. Allow the engine to cool.
- B. Wrap a thick cloth around pressure cap.
- C. Partially unscrew pressure cap slowly while firmly holding cap down, then pause to allow pressure to release.
- D. When system pressure is released, fully unscrew pressure cap while continuing to hold cap down. Slowly release downward pressure from pressure cap.
- E. Remove cap.



WARNING

To prevent personal injury and / or death, or damage to property, if vehicle is equipped with an automatic transmission, have a qualified technician regularly check operation of transmission neutral start switch. If unit starts in gear, the vehicle may inadvertently move.



WARNING

To prevent personal injury and / or death, or damage to property, exercise care when working on vehicles with running engines that are equipped with an automatic fan clutch. The fan engages when engine coolant reaches a predetermined temperature or the refrigerant pressure (if equipped with air conditioning) reaches a predetermined setting. The fan will start with no advance warning.

Underhood and Fluid Checks

Component	Description
Belts	Open the hood and check that the water pump, alternator, and A/C compressor belts are not frayed and have no excessive cracking, loose fibers, or other signs of wear. Ensure they are snug and secure.
Fan Cooling Ring and Shroud	Check for security of engine-mounted fan cooling ring and fan shroud.
Engine Oil	Use the engine oil dipstick to verify that the engine oil level is correct. Refer to the engine manual for the correct fluid and lubricant specifications.
Automatic Transmission Fluid	With the engine running, use the dipstick to ensure the correct transmission fluid level is present. Refer to the Allison Transmission Manual for correct fluid and lubricant specifications.
Engine Coolant	Ensure the fluid is between the ADD and MAX fluid level range as marked on the reservoir. Do not remove the pressure cap until the coolant has cooled; failure to do so may result in personal injury. If additional fluid is necessary, see the Maintenance section of this manual to find the correct fluid type before filling.
Windshield Washer System Fluid	Inspect the fluid level through the plastic reservoir. If additional fluid is necessary, only use windshield washer fluid.
Power Steering Fluid	Check that the fluid is between the MIN (COLD) and MAX (HOT) marks. If additional fluid is necessary, see the Maintenance section of this manual to find the correct fluid type before filling.
Brake Fluid Check	Check to ensure the brake fluid is between the MIN and MAX lines. If additional fluid is necessary, see the Maintenance section of this manual for the correct fluid type before filling.
Radiator and Charge Air Cooler	Inspect the radiator and charge air cooler for damage and / or blockage. Inspect all radiator and heater hoses.
Hood and Hood Latches	Close and latch the hood. Check that the hood is securely latched in place with the hood latches.

Vehicle Inspection Guide

Interior Visual and Operational Checks

Component	Description
Interior Mirror	Ensure the interior mirror is clean and adjusted to provide a clear view of the entire rear of the bus including the rear windows. To adjust the mirror, loosen the bolts and nuts in the slotted holes. After moving the mirror to the desired position, tighten the bolts and nuts.
Window Operation	Ensure windows are free of dirt, fog, condensation and snow. Ensure the driver and passenger windows can open and close completely.
Engine Starting	With the parking brake applied, insert the key and turn the ignition switch to start the engine. Ensure the gauges perform an ON and OFF cycle during the engine start up. On vehicles with V-8, wait until the WAIT TO START indicator goes out. On vehicles with the I-6 the WAIT TO START indicator is an available option. NOTE: All remaining checks are to be performed with the engine running.
Instrumentation	With engine running, check gauges for oil pressure, temperature, alternator, and fuel levels.
Wiper Blades	Look through the windshield to inspect both wipers for signs of wear, damage, or signs of aging on the rubber blades. Check wiper operation.
Passenger Entry	Ensure the door opens and closes completely. Ensure the entry steps are clear, and the treads are secure and are in good condition.
Heater Leaks / Fans	Inspect for interior heater fluid leaks and check fan operation at all heater locations.
Emergency Devices	Sound the horn. Turn on the heater and defroster. Check the windshield wipers and washers for proper operation. Using cross-view mirrors and another person, or the lamp check system, verify that the front and rear exterior directional signal lights are working. Ensure that all interior lights are working properly.

Interior Visual and Operational Checks (cont.)

Component	Description
Air Brake Check	<p>Check the air brakes as follows:</p> <ul style="list-style-type: none"> • Install wheel chocks.. Push in parking brake and start engine • Check the air compressor or governor cut-out pressure (approximately 120 psi [827 kPa]). • Turn engine OFF and then turn key to ON position. • Without brake pedal applied, note air pressure drop for one minute([It should be less than 2 psi (14 kPa) • Depress and hold brake pedal making sure there is no more than a 3 psi (21 kPa) per minute pressure drop. For combination vehicles, there should be no more than 28 kPa (4 psi) per minute pressure drop. • Step on and off brake pedal and check for warning indicator and buzzer to come on at about 60 to 70 ± 6 psi (414 to 483 kPa)
Air Brake Check (Cont)	<ul style="list-style-type: none"> • Step on and off brake and check to ensure the parking brake knobs pop out between 20 and 45 psi (138 to 310 kPa) • Restart engine, shift into a low gear, and gently pull against service and parking brakes separately to ensure they will hold.
Hydraulic Brake Check	<p>Pump the brake pedal three times. Then apply firm pressure to the pedal and hold for five seconds. The pedal should not move, and the brake pressure indicator should not illuminate.</p>
Accelerator Pedal	<p>Check for smooth, non-binding pedal action.</p>
Shift Selector	<p>NOTE: Foot brake pedal must be pressed to shift out of the Park (P) position. Check for proper functioning of the shift selector and linkage.</p>
Parking Brake Check	<p>NOTE: Foot brake pedal must be pressed to release the parking brake and to shift out of the Park (P) position. With foot on brake pedal, shift the transmission into a forward gear. Take your foot off the service brake pedal, and allow the bus to idle forward. If the bus moves forward, the parking brake has malfunctioned. Stop the bus with the service brake and have the vehicle serviced immediately.</p>

Vehicle Inspection Guide

Interior Visual and Operational Checks (cont.)

Component	Description
(Optional) Backup Alarm Check	Check for proper operation of the Backup alarm. See Driver Section for Backup alarm operation. NOTE: Foot brake pedal must be pressed to release the parking brake and to shift out of the (P) Park position.
Optional Wheelchair Lift System Operational Check	Inspect the optional wheelchair lift system for proper operation every day. Refer to the lift manufacturer's operation manual for items that should be checked before operation.

Integrated Air Conditioning System (IC Air)

Component	Description
Compressor Belts	Check for tension and wear. Inspect for properly tensioned belt. This ensures maximum compressor performance and belt life.
Evaporator Filters	Check for cleanliness. A properly maintained filter maximizes air flow and system performance.
Hoses	Check that hoses are secured and protected. Prevents the possibility of refrigerant leaks.
Wiring Harnesses	Check that hoses are secured and protected. Prevents the possibility of electrical shorts.
Condenser Coil	Check for cleanliness. A properly maintained condenser coil will ensure maximum heat transfer and system performance.
Sight Glass Moisture Indicator	Check color of sight glass: <ul style="list-style-type: none"> • GREEN = Absence of moisture • YELLOW = Moisture is present IMMEDIATE SYSTEM SERVICE REQUIRED

Auxiliary Fuel-Fired Heater System

Component	Description
Coolant hoses, clamps, and valves	Check that hoses are secured and protected. Check for clamp tightness. Ensure valves are open.
Coolant level	Maintain the engine manufacturer's recommended coolant level, and ensure that the heater is properly bled after service on / or involving the coolant system.
Fuel lines / leaks	Visually check all fuel lines for leaks. Check, and if necessary, replace fuel filter inserts.
Electrical lines and connections	Visually check all electrical lines and connections for corrosion.
Battery system condition	Maintain batteries and all electrical connections in good condition. With insufficient power, the heater will not start. Low and high voltage cutouts will shut the heater down automatically.
Proper fuel	Use fuel suitable for the climate (see engine manufacturer's recommendations). Blending used engine oil with diesel fuel is not permitted. Biodiesel of 5% or less is permitted. Greater levels of Biodiesel may result in failures to the heater.

Emergency Exits and Equipment

Component	Description
Roof Hatch	Inspect the roof hatch daily for proper opening, buzzer warning, if supplied, and operating instruction decal attachment. Ensure the emergency hatch is completely closed and secure.
Emergency Exits	Check all emergency exits every day for proper opening, buzzer warning, and operating instruction decal attachment. Check to see that all emergency exit doors can be opened, and that they are firmly closed. Ensure all emergency door release bars are properly secured, and the kickout window handle is properly latched.

Vehicle Inspection Guide

Emergency Exits and Equipment (cont.)

Component	Description
Warning Lights, Stop Arm, Crossing Gate, and Entrance Door Check	<ul style="list-style-type: none">• Check to see that the AMBER and RED warning lights are operating properly. To check these lights use the Exterior Lamp Check procedure in the Lights section of this manual.• Verify the Stop Arm and Crossing Gate are working properly and extend completely• Verify the entrance door is opening and closing properly.• Verify the flasher warning lights and stop arm are working properly with the flasher switches and entrance door operations. Check to see that the AMBER Warning Lights are flashing. When the entrance door is opened, check to see that the AMBER Warning Lights stop flashing and the RED warning lights begin flashing, and Crossing Gate and Stop Arm are extended. Close the entrance door and observe that flasher warning lights go OFF. There is an optional feature that will automatically turn OFF the pupil warning lights after the bus has started to move.
Emergency Equipment	If equipped / required by state law, check to ensure that the fire extinguisher, reflective triangles, first aid kit and body fluid clean up kit are in place and secure.

SECTION 3 — INSTRUMENTATION

Instrument Panel Gauge Cluster

The instrument panel gauge cluster includes the instrument gauges, warning indicators, and an integral digital display, which will provide odometer, transmission gear indication, and compass heading and outside temperature displays. This instrument panel gauge cluster displays the crucial operational functions of the vehicle. The following are descriptions and

illustrations of the gauges, warning indicators, and integral digital display options.

For Vehicles NOT Equipped with Selective Catalytic Reduction (SCR) System:

NOTE: See following tables for descriptions of callout items 26-54.

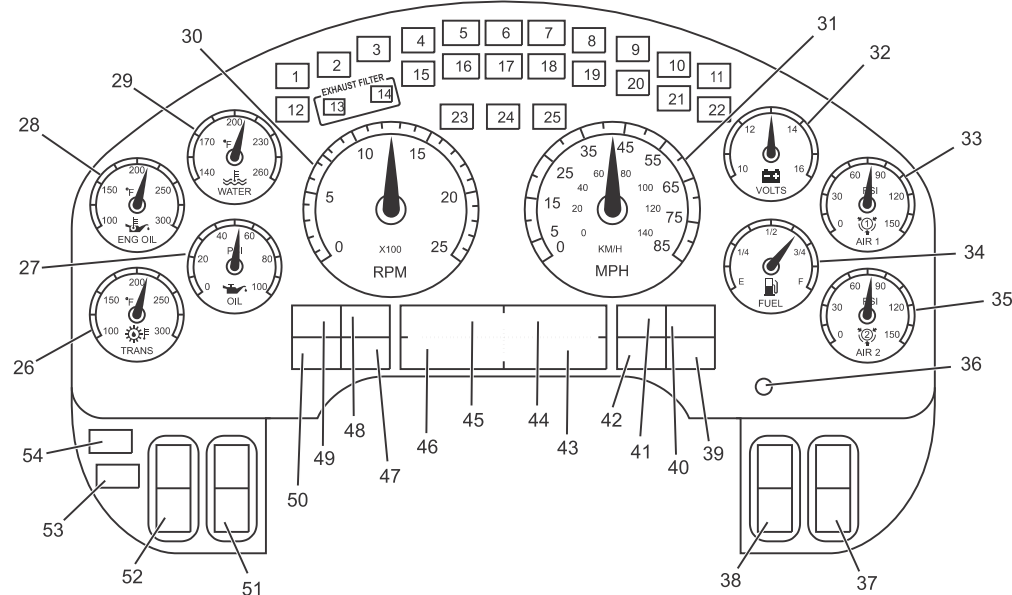

0000037191

Instrumentation

For Vehicles Equipped with Selective Catalytic Reduction (SCR) System:

NOTE: See following tables for descriptions of callout items 26-54.

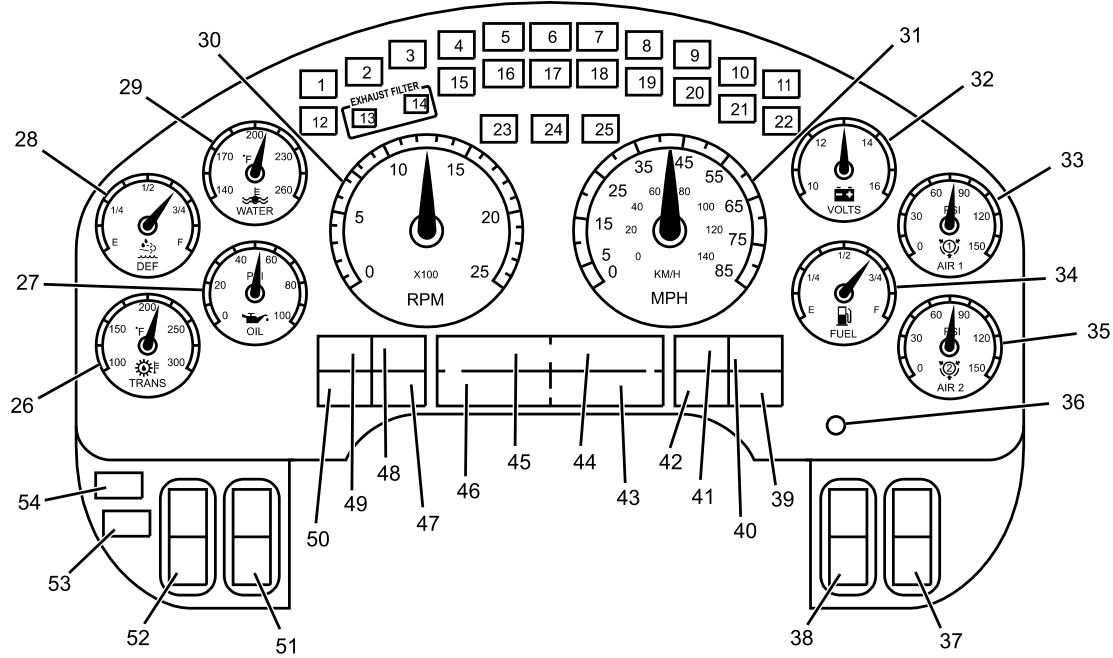





0000055747





Warning Indicators





The instrument panel gauge cluster may contain as many as 25 individual LED warning indicators. These indicators are used to alert the driver of vehicle conditions and functions and may indicate a WARNING or STOP condition. They are turned ON by the software in the instrument panel gauge cluster. At ignition, the warning indicators will illuminate for 8 to 10 seconds, as part of the vehicle power-up sequence.



Item No.	Indicator	Description
1	 3813045	Optional Wait to Start Lamp <ul style="list-style-type: none"> • Illuminates YELLOW when intake air heaters and glow plugs are in operation and special starting procedures are required. Duration of Wait to Start will vary upon ambient air temperature. • Flashes YELLOW when optional engine starting protection activated. Optional feature prevents engine cranking to cool starter motor and prevent burn out. Once starter motor has cooled, normal function is restored.
2	IDLE SHUT DOWN 8487074	Illuminates YELLOW to alert driver that vehicle idle shutdown timer will turn engine OFF in 30 seconds.



Item No.	Indicator	Description
3	 8487080	Illuminates YELLOW. Used in conjunction with other warning indicators or general text and warning messages and may be accompanied by an audible alarm to indicate an Alert condition to the operator.
4	 8487084	AWL - The Amber Warning Lamp (AWL) illuminates when the vehicle needs to be serviced at the first available opportunity.
5	 8487086	RSL - The Red Stop Lamp illuminates RED when a serious problem has occurred. This lamp is accompanied by a message on the odometer display and an AUDIBLE ALARM. If the Red Stop Lamp illuminates, immediately pull the vehicle safely off the roadway, turn ON the flashers, set the parking brake, place warning devices and stop the engine. The engine should not be restarted prior to being serviced.
6	BRAKE  PRESSURE 3813046	Illuminates RED when a failure in the service brake system has occurred. If the Brake Pressure warning indicator illuminates, safely stop the vehicle as soon as possible and seek service immediately.

Instrumentation

Item No.	Indicator	Description
7		Illuminates RED when the parking brake is applied. If the brake warning indicator does not illuminate, or if it stays on with the parking brake not engaged, seek service immediately.
8		Illuminates when the emergency exit is not securely closed when the key switch is in the ACC (Accessory) or ON position.
9		Illuminates YELLOW when the transmission is not engaged in the selected gear. The warning indicator goes out when the gearshift lever is adjusted to the appropriate gear. Refer to the Transmission Operation Manual for more information.
10		Illuminates YELLOW when the optional lift door is not securely closed when the key switch is in the ON position.
11		Illuminates YELLOW when the traction control system is turned OFF. It also illuminates momentarily when the traction control system is on and is limiting wheel spin. Blinks on if slippery road conditions may exist. If this happens, adjust your driving accordingly. Refer to the Operation section for more information.

Item No.	Indicator	Description
12		For vehicles not equipped with Selective Catalytic Reduction (SCR) system: this field is not in use. For vehicles equipped with Selective Catalytic Reduction (SCR) system: Illuminates YELLOW (Solid or Flashing) when the Diesel Exhaust Fluid (DEF) level is low. For details, see Exhaust Aftertreatment < Operation section.
13		Illuminates YELLOW when exhaust system components are operating under normal conditions and exhaust gases are at extremely high temperatures.
14		Diesel Particulate Filter (DPF) status indicator. Illuminates YELLOW (Solid or Flashing) to indicate the need to regenerate the Diesel Particulate Filter. (See Exhaust Regeneration < Operation Section)
15		MIL-The Malfunction Indicator Lamp (MIL) illuminates when the On-Board Diagnostics (OBD) detects a malfunction related to the emissions control system. The illuminated MIL indicates that the vehicle needs to be serviced at the first convenient opportunity. Lamp may remain active after repair until system operation confirms repair.

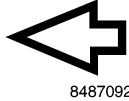
Item No.	Indicator	Description
16	<p>SERVICE</p>  <p>8487088</p>	<p>Illuminates RED when a parking brake system malfunction has been detected. If the Service Parking brake indicator stays illuminated, have the system serviced immediately.</p>
17	 <p>8487073</p>	<p>Optional indicator illuminates RED immediately after ignition is turned ON to remind operator to fasten seat belt. Optional Seat Belt Reminder with Seat Belt Monitoring causes initial visual indication, then flashes with audible alarm when ignition is on, parking brake is released, and seat belt is not fastened.</p>
18	<p>BRAKE FLUID </p> <p>3813054</p>	<p>Illuminates RED when the brake fluid falls below the safe operating level.</p>
19	<p>RED FLSHR</p> <p>3813049</p>	<p>Illuminates when the RED flasher warning lights are activated.</p>
20	<p>AMBER FLSHR</p> <p>3813048</p>	<p>Illuminates when the AMBER warning flasher lights are activated.</p>

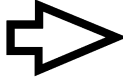
Item No.	Indicator	Description
21	 <p>8487089</p>	<p>Illuminates YELLOW when an antilock brake system malfunction has been detected. If the ABS indicator stays illuminated or continues to flash, have the system serviced immediately.</p>
22	<p>ECON</p> <p>8487091</p>	<p>Illuminates YELLOW when transmission Economy Mode is selected. Refer to the Transmission Operation Manual for more information.</p>
23	 <p>8487092</p>	<p>Flashes GREEN when the left turn signal or the hazard lights are turned ON.</p>
24	 <p>8487094</p>	<p>Illuminates BLUE when the high beam head lamps are turned ON.</p>
25	 <p>8487093</p>	<p>Flashes GREEN when the right turn signal or the hazard lights are turned ON.</p>

NOTE: If the MIL is illuminated, it is the vehicle owner's responsibility to have the engine repaired or face fines.

Instrumentation

Instrument Panel Gauge Cluster













WARNING



To prevent personal injury and / or death, or damage to property, never operate the vehicle when insufficient air pressure (less than 70 psi [483 kPa]) is indicated for either the primary or secondary air system. The volume of air required to stop the vehicle may be greater than that available. Have the brake system checked and repaired before returning the vehicle to service.

There are 10 gauges in the instrument panel gauge cluster to help monitor the vehicle while in service. Most gauges have in-gauge warning indicators that turn ON if the gauge pointer moves into an out-of-acceptable-range condition. When the ignition switch is turned ON, the gauge indicators will be on. Metric versions of the gauges and speedometer are available as an option.

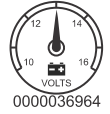
NOTE: If any indicator fails to go out after starting engine, stop engine and determine cause of the gauge indication that is out of acceptable range.

Item No.	Indicator	Description
26		Indicates the transmission lubricant temperature in degrees Fahrenheit (°F) (if equipped).
		Indicates the engine lubricant temperature in degrees Fahrenheit (°F) (if equipped).
27		Indicates engine oil pressure in pounds per square inch (psi).
28		For vehicles not equipped with Selective Catalytic Reduction (SCR) system: Indicates the engine lubricant temperature in degrees Fahrenheit (°F) (if equipped).
		For vehicles equipped with Selective Catalytic Reduction (SCR) system: Indicates the approximate DEF level in the DEF tank.
29		Indicates engine coolant temperature in degrees Fahrenheit (°F).





Item No.	Indicator	Description
30		The tachometer indicates engine speed (rpm). The engine can be operated between idle speed and high idle speed without damage but should not be allowed to over-speed (such as when going downhill).
31		The speedometer indicates the vehicle speed in miles per hour (mph) and kilometers per hour (km/h).
32		Indicates the battery voltage (volts) when the ignition switch is in the ON position.
33		Provides indication of air pressure available for the primary air brakes in pounds per square inch (psi).

Item No.	Indicator	Description
34		Indicates the approximate fuel level in the fuel tanks.
35		Provides indication of air pressure available for the secondary air brakes in pounds per square inch (psi).

Direct Drive Warning Indicators

The instrument panel gauge cluster also houses eight direct drive warning indicators that alert the operator of various conditions of the vehicle. They are in two groups of four each, located on both sides of the LED quadrant displays. The warning indicators that are not used in this particular model will be substituted with a blank cover plate.

NOTE: There are several variation of Direct Drive Warning Indicators. Actual indicator configuration may vary.

Item No.	Indicator	Description
39		Optional transmission fluid / filter change indicator illuminates YELLOW. Refer to Transmission Operation Manual for additional information
40		Illuminates YELLOW when exhaust system components are operating under normal conditions and exhaust gases are at extremely high temperatures.
41		Diesel Particulate Filter (DPF) status indicator. Illuminates YELLOW (solid or flashing) to indicate the need to regenerate the Diesel Particulate Filter. (See Exhaust Regeneration > Operation Section)
42		Not used
47		Electronic Stability Control (if equipped) illuminates YELLOW; a flashing indicator advises the electronic stability control is engaged; an indicator which stays lit advises of a fault in the system.
48		Not used.
49		Not used.
50		Not used.

Integral Digital Display

The integral digital display is located below the speedometer and the tachometer. It is arranged in four quadrants that display vehicle information. The four quadrants can be individually selected by using the display control button.

Display Control. The Display control is used to scroll to a quadrant and to select the various modes within a quadrant. To navigate between quadrants, turn and release the control either clockwise or counterclockwise. To select the screens within a quadrant, press and release the control. Pressing and holding the control for more than 3 seconds to reset the value of the selected quadrant parameter (if the parameter can be reset). The selected quadrant is identified by a vertical bar located in the far right of quadrant. In Quadrant 1, the odometer screen can be toggled between English and Metric, by pressing and holding the control.

Integral Digital Display

Item No.	Quadrant Number and Message Function	Message Description
36	Display Control	Toggles the information display from one screen to the next when pressed and released.
43	Quadrant 2: General Text and Warning Messages	Displays a variety of messages ranging in priority necessary for vehicle monitoring and operation, and vehicle malfunction warnings. Some messages are used in conjunction with instrument panel gauge cluster warning indicators (see list of messages in the Instrument Panel Gauge Cluster > Integral Digital Display Detailed Information section in Controls / Features).

Instrumentation

Integral Digital Display (cont.)

Item No.	Quadrant Number and Message Function	Message Description
44	Quadrant 1: Informational Messages	<p data-bbox="875 259 1207 283">Informational Display Screens:</p> <ul data-bbox="909 306 1406 1094" style="list-style-type: none"><li data-bbox="909 306 1064 330">• Odometer<li data-bbox="909 353 1116 377">• Trip Odometer<li data-bbox="909 400 1164 424">• Total Engine Hours<li data-bbox="909 447 1070 471">• Trip Hours<li data-bbox="909 494 1253 518">• Machine PTO A or B Hours<li data-bbox="909 541 1302 565">• Machine Trip PTO A or B Hours<li data-bbox="909 588 1161 612">• Engine PTO Hours<li data-bbox="909 635 1209 659">• Engine PTO Trip Hours<li data-bbox="909 682 1271 706">• Instantaneous Fuel Economy<li data-bbox="909 729 1257 753">• Trip Average Fuel Economy<li data-bbox="909 776 1300 801">• Machine PTO Fuel Used A or B<li data-bbox="909 823 1348 848">• Machine PTO Trip Fuel Used A or B<li data-bbox="909 870 1209 895">• Engine PTO Fuel Used<li data-bbox="909 917 1257 942">• Engine PTO Trip Fuel Used<li data-bbox="909 964 1164 989">• Trip Idle Fuel Used<li data-bbox="909 1012 1406 1036">• Axle Load Indication (Front and / or Rear)<li data-bbox="909 1059 1271 1083">• Diesel Particulate Filter Level

Integral Digital Display (cont.)

Item No.	Quadrant Number and Message Function	Message Description
45	Quadrant 4: Transmission Gear Indication	Transmission gears for the Allison P-R-N-D-L gear selection display, or the Eaton® Transmission display.
46	Quadrant 3: Compass Heading / Outside Temperature	(Optional) Displays compass heading when vehicle is equipped with a compass module. Displays outside temperature (reading is obtained from the temperature sensor).

Integral Digital Display Detailed Information

NOTE: The available display screens are dependent on the configuration of the vehicle.

Quadrant 1: Informational Displays

Quadrant 1: Display Messages	Description
Odometer	The odometer displays the total distance traveled. Display Format: 100,000.0 TRIP MILES TRIP KM
Trip Odometer	The trip odometer displays a record of the elapsed distance traveled since the last reset. NOTE: The trip hours and trip miles are independently reset. Display Format: 100,000.0 TRIP MILES TRIP KM

Instrumentation

Quadrant 1: Informational Displays (cont.)

Quadrant 1: Display Messages	Description
Total Engine Hours	<p>The Engine Hour display provides a record of accumulated engine hours, and will not show any increase unless the engine is running.</p> <p>NOTE: This display function cannot be reset.</p> <p>Display Format: 100,000.0 HOURS</p>
Trip Hours	<p>The Trip Hour display provides a record of elapsed engine hours since the last reset.</p> <p>NOTE: The trip hours and trip miles are independently reset.</p> <p>Display Format: 100,000.0 TRIP HOURS</p>
Machine PTO A or B Hours	<p>This display will provide a record of the total accumulated Machine PTO hours, while PTO function A or B is engaged.</p> <p>Display Format: 100,000.0 PTO HOURS A PTO HOURS B</p>

Quadrant 1: Informational Displays (cont.)

Quadrant 1: Display Messages	Description
Machine Trip PTO A or B Hours	<p>This display will provide a record of the total accumulated Machine Trip PTO hours, while PTO function A or B is engaged.</p> <p>Display Format: 100,000.0 PTO TRP HOURS A PTO TRP HOURS B</p>
Engine PTO Hours	<p>This display will provide a record of the Engine PTO hours sent from engine.</p> <p>Display Format: 100,000.0 ENG PTO HOURS</p>
Engine PTO Trip Hours	<p>This display will provide a record of the Engine PTO Trip hours sent from engine.</p> <p>Display Format: 100,000.0 ENG PTO TRP HOURS</p>
Instantaneous Fuel Economy	<p>This display provides a record of the instantaneous fuel economy sent from the engine. The display indicates miles per gallon or liters per 100 kilometers, corresponding to the units selected while in the odometer mode.</p> <p>Display Format: 30.0 INST MPG INST L/100KM</p>

Instrumentation

Quadrant 1: Informational Displays (cont.)

Quadrant 1: Display Messages	Description
Trip Average Fuel Economy	<p>The display value will indicate the average fuel economy value since the last reset of the trip odometer. The display indicates in miles per gallon or liters per 100 kilometers, corresponding to the units selected while in the odometer mode.</p> <p>Display Format: 30.0 TRIP MPG TRIP L/100KM</p>
Machine PTO Fuel Used A and B	<p>The display value indicates the calculated Machine PTO Fuel Used.</p> <p>Display Format: 100,000.0 PTO GAL A PTO GAL B PTO L A PTO L B</p>
Machine PTO Trip Fuel Used A and B	<p>The display value indicates the calculated Machine PTO Trip Fuel Used.</p> <p>Display Format: 100,000.0 PTO TRP GAL A PTO TRP GAL B PTO TRP L A PTO TRP L B</p>

Quadrant 1: Informational Displays (cont.)

Quadrant 1: Display Messages	Description
Engine PTO Fuel Used	The display value indicates the calculated Engine PTO Fuel Used. Display Format: 100,000.0 ENG PTO GAL PTO TRP L
Engine PTO Trip Fuel Used	The display value indicates the calculated Engine PTO Trip Fuel Used. Display Format: 100,000.0 ENG PTO TRP GAL ENG PTO TRP L
Trip Idle Fuel Used	The display value indicates the calculated Trip Idle Fuel Used. Display Format: 100,000.0 TRP IDL GAL TRP IDL L

Quadrant 1: Informational Displays (cont.)

Quadrant 1: Display Messages	Description
Axle Load Indication	<p>The instrument panel gauge cluster displays an approximate value of axle load for the front and / or rear axles.</p> <p>NOTE: Axle load readings are most accurate on a level surface with parking brake released.</p> <p>Display Format: approx. 45.0 FT LBSX1000 FT KGX1000 RR LBSX1000 RR KGX1000</p>
Diesel Particulate Filter Level	<p>The instrument panel gauge cluster displays the relative Diesel Particulate Filter (DPF) Level. The instrument panel gauge cluster displays the following graph:</p> <div data-bbox="923 713 1396 837" style="text-align: center;"> <p style="text-align: right; margin-right: 50px;">8487412</p> </div> <p>With L (low) on the left and H (high) on the right, the graph is shown by bars each representing a 10% increase / decrease in soot level.</p> <p>The instrument panel gauge cluster displays the last received level until a new value is received, or until the instrument panel gauge cluster detects that it has not received a response to the SPN request, in which case it shall display the words DATA N/A within the bar graph.</p>

Quadrant 2: Text and Warning Messages

These messages inform the driver of vehicle conditions. If the message flashes, it will flash for 3 - 5 seconds, and then will be displayed for an additional 3 - 5 seconds. If more than one message is viewable, the displayed message will be followed by an asterisk (*), indicating multiple messages. To view additional

messages, press and release the Display Control button to proceed to the next message.

The following is a list of the **routine** text and warning messages that can be displayed and is dependent upon the configuration of your vehicle:

Quadrant 2: Text and Warning Messages

Quadrant 2: Display Messages	Description	Flash (Yes / No)	Warning Indicator Association
PARKD REGEN ACTIVE	Message is displayed during a parked regeneration.	No	No
Washer Fluid Low	Indicates low washer fluid level.	Yes	No
Electrical Fault	When instrument panel gauge cluster's ability to display diagnostic codes is enabled, this message is displayed when there are active diagnostic codes.	Yes	No
Check A/C	Indicates a fault in the HVAC System.	Yes	No
PARKD REGEN INHIBITED	Message is displayed when parked regeneration has been requested, but is not performed due to a vehicle interlock or an engine fault.	No	No
Air Filter Restriction	Message displayed indicates restricted air flow to the engine.	Yes	No
Exterior Lamp Check Active	Message displayed indicates Exterior Lamp Check is in progress.	Yes	No
HVAC Temp Setting	Bar graph displayed show temperature setting in low to high increments.	No	No
Activate HVAC Front Blower	Bar graph displayed show blower speed setting in OFF and low to high increments.	No	No

Instrumentation

Quadrant 2: Text and Warning Messages (cont.)

Quadrant 2: Display Messages	Description	Flash (Yes / No)	Warning Indicator Association
Air Pressure Diagnostic		Yes	No
Cruise	Indicates that the Cruise Control System is turned ON.	No	No
Fuel Filter	Indicates that the fuel filter is clogged.	Yes	No
Check Brake Switch		Yes	No
Check Pupil Warning Indicator		Yes	No
Check Stop Arm / Crossing Gate		Yes	No
Check Exterior Lamps		Yes	No
Engine Control Shutdown		Yes	No
Engine Control System Error		Yes	No
PARKD REGEN REQUIRED	Indicates parked regeneration is necessary.	No	No
PARKD REGEN INHIBITED ENG TMP	Message is displayed when engine coolant temperature is below 76.6°C (170°F).	No	No
REGEN INHIBIT SWITCH ACTIVE	Message is displayed when Regen Inhibit Switch is ON and regeneration is disabled.	No	No
PARKED REGEN AVAILABLE		No	No
Low Coolant Level	Message is displayed when coolant level is less than or equal to 80%.	Yes	No
Stop Engine	Message is displayed when Red Stop Lamp is illuminated.	Yes	Red Stop Lamp

Quadrant 2: Text and Warning Messages (cont.)

Quadrant 2: Display Messages	Description	Flash (Yes / No)	Warning Indicator Association
Warn Engine (Priority 1 or 2)	(1) Message is displayed when ECM turns ON the Red Stop Lamp. (2) Message is displayed when ECM requests the Amber Warning Lamp and not the Red Stop Lamp.	Yes	(1) Red Stop Lamp (2) Amber Warning Lamp
Low Engine Oil Level	Message is displayed when engine oil level is less than or equal to 80%.	Yes	No
Change Engine Oil	Message is displayed when engine oil change is detected as necessary.	Yes	No
Water in Fuel	Message is displayed when water in fuel is present.	Yes	No
Electrical Fault (Priority 1 or 2)	(1) Message is displayed when EGC requests the Red Stop Lamp. (2) Message is displayed when EGC requests the Amber Warning Lamp.	Yes	(1) Red Stop Lamp (2) Amber Warning Lamp
Check Trans	Message is displayed when transmission needs to be serviced.	Yes	Amber Warning Lamp
Trans Temp	Message is displayed when transmission turns on the Amber Warning Lamp. Not available with all transmissions.	Yes	Amber Warning Lamp
Gen Trns Flt	Message is displayed when transmission turns on RED Stop, MIL, or PROTECT, or the YELLOW Warning indicator without the conditions to display Check Trans, Trans Temp, Trans Oil Life, Trans Oil Filter, or Trans Service. Not available with all transmissions.	Yes	Yes (see description)
Trans Oil Life	Message is displayed when transmission oil needs changed. Not available with all transmissions.	Yes	No

Instrumentation

Quadrant 2: Text and Warning Messages (cont.)

Quadrant 2: Display Messages	Description	Flash (Yes / No)	Warning Indicator Association
Trans Oil Filter	Message is displayed when transmission oil filter needs to be changed. Not available with all transmissions.	Yes	No
Trans Service	Message is displayed when transmission needs service. Not available with all transmissions.	Yes	No
DPF Ash Service Required	Message is displayed when diesel particulate filter ash level requires service / cleaning.	Yes	No
See Visor For Info	Message is displayed indicates the particulate trap indicator must be on or must flash.	Yes	Yes (see description)
ECM, TCM, Shift Selector, ABS, Retarder – Driveline, EGC, Compass Module, ESC, VSM, SD, AGSP, TPMS, Exhaust Module, Telematics, AGSP 2, SIC 2, AGSP 3, SIC 1, PAM, Service Tool, Global	Message is displayed when a module other than the engine requests the Red Stop Lamp warning indicator.	Yes	Red Stop Lamp
ECM, TCM, Shift Selector, ABS, Retarder – Driveline, EGC, Compass Module, ESC, VSM, SD, AGSP, TPMS, Exhaust Module, Telematics, AGSP 2, SIC 2, AGSP 3, SIC 1, PAM, Service Tool, Global	Message is displayed when a module other than the engine requests the Amber Warning Lamp.	Yes	Amber Warning Lamp
Retarder Temp	Message is displayed when instrument panel gauge cluster receives signal from the Retarder – Driveline requesting the Amber Warning Lamp.	Yes	Amber Warning Lamp

Quadrant 2: Text and Warning Messages (cont.)

Quadrant 2: Display Messages	Description	Flash (Yes / No)	Warning Indicator Association
Gen Rtrd Flt	Message is displayed when instrument panel gauge cluster receives a signal from the Retarder – Driveline requesting the RED warning, MIL, or PROTECT indicator, or the Amber Warning Lamp without the conditions to display Retarder Temp.	Yes	Yes (see description)
DRV Reward Expected		No	No
DRV Reward Good		No	No
DRV Reward Excellent		No	No
DRV Reward Penalty		No	No
DRV Reward Increasing		No	No
DRV Reward Decreasing		No	No
VSL Ovrđ Active		No	No
VSL Ovrđ Expiring		No	No
	Blank screen, available only when engine rpm less than or equal to 325 rpm, or vehicle speed less than 2 mph (3 km/h).	No	No
Calibrate Compass	Message is displayed when vehicle speed is less than 2 mph (3 km/h) and the operator has not requested Calibrate Compass in the current ignition cycle.	No	No
End Calibration	Message is displayed when vehicle speed is less than 2 mph (3 km/h) and the operator has requested Calibrate Compass in the current ignition cycle.	No	No

Instrumentation

Quadrant 2: Text and Warning Messages (cont.)

Quadrant 2: Display Messages	Description	Flash (Yes / No)	Warning Indicator Association
Calibration Ended	Message is displayed when vehicle speed is less than 2 mph (3 km/h) and the operator has requested Calibrate Compass in the current ignition cycle.	No	No
Declination Zone	Message is displayed only when vehicle speed is less than 2 mph (3 km/h).	No	No
DEF Low Refill Soon	Diesel Exhaust Fluid (DEF) needs to be refilled.	No	DEF Level Lamp
DEF Low Eng Derated	Diesel Exhaust Fluid (DEF) level is very low and engine performance is limited.	No	DEF Level Lamp and Amber Warning Lamp (AWL)
DEF Low Eng Derated 5mph	Diesel Exhaust Fluid (DEF) level is 0%. Engine performance is limited and vehicle speed is limited to 5 mph (8 km/h).	No	DEF Level Lamp, Amber Warning Lamp, and Red Stop Lamp
DEF Quality Service Soon	Diesel Exhaust Fluid (DEF) quality problem is detected.	No	Amber Warning Lamp
DEF Quality Derated	Diesel Exhaust Fluid (DEF) quality problem has been present for 1 hour or longer. Engine performance is limited.	No	Amber Warning Lamp
DEF Quality Derated 5 mph	Diesel Exhaust Fluid (DEF) quality problem has been present for 3 hours or longer. Engine performance is limited and vehicle speed is limited to 5 mph (8 km/h).	No	Amber Warning Lamp, Red Stop Lamp

Warning Messages

In addition to the Diagnostic Trouble Codes (DTC), the digital display will display a warning message whenever an engine indicator is illuminated. This warning message will be toggled with the normal DTC as follows:

Amber Warning Lamp indicator: WARN ENGINE message

Red Stop Lamp indicator: STOP ENGINE message

The following chart provides the warning messages that are displayed along with corresponding Instrument panel gauge cluster indicators.

Warning Message

N9 and N10 Engines	
Warning Indicator	Warning Message
Red Stop Lamp	STOP ENGINE
Amber Warning Lamp	WARN ENGINE

Outside Temperature and Compass Displays (Optional)

The optional Outside Temperature and Compass Heading is displayed in Quadrant 3. Typical displays for Temperature and

Compass Heading are listed in the following table. The display provides both the outside ambient temperature and the relative direction of the vehicle within a particular geographical zone. See below for details of calibration and use.

Vehicle must be moving to acquire an accurate temperature.

Quadrant 3: Display Messages

Quadrant 3: Display Messages	Description
Outside Temperature and Compass Heading	<p>Display Format:</p> <div style="border: 1px solid black; padding: 5px; margin-bottom: 10px;">32°F SE</div> <div style="border: 1px solid black; padding: 5px; margin-bottom: 10px;">0°C SE</div> <div style="border: 1px solid black; padding: 5px;">32°F NO CAL</div> <p style="text-align: right; font-size: small;">8590030</p>

Instrumentation



Outside Temperature Reading

The Outside Temperature is displayed on the first line of Quadrant 3 above the Compass Heading. The temperature sensor is located near the front bumper. Due to its location, the sensor readings can be affected by road or engine heat during idling or prevailing driving conditions (extended slow movement).

The display will be in °F or °C, depending on the units selected while in the odometer mode.

Quadrant 4: Transmission Gear Displays

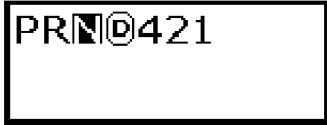
Quadrant 4: Transmission Gear Indications

Description	Transmission Gear Indications
Allison P-R-N-D-L gear display	 8487430
Eaton® Transmission display	 8590031

Optional Instrument Panel Gauge Cluster Compass Calibration Procedure

All new vehicles with an optional compass must have an initial compass calibration performed. A compass calibration may or may not have been completed at the vehicle assembly plant. If the compass headings are noticeably incorrect, or become noticeably incorrect, or the NO CAL message is displayed, the Declination Zone may need to be reset to agree with the current geographic location, or the Compass Directional Calibration will need to be recalibrated.

The compass direction is displayed in the lower left quadrant of the instrument panel gauge cluster display just below the outdoor temperature reading. Text messages necessary to calibrate the compass can be found in the instrument panel gauge cluster display in the lower right quadrant (Quadrant 2) of the display. Twist the instrument panel gauge cluster display knob until the cursor is flashing in the lower right quadrant. Press the instrument panel gauge cluster display knob until the desired text message is displayed. Compass Calibration related text messages include Calibrate Compass, Compass Declination, Declination Zone #, and End Calibration.

NOTE: The Declination Zone for the location where the Compass Calibration procedure is being performed must be set first and thereafter the Compass Directional Calibration procedure can be performed. Both procedures are listed on the following pages and must be followed exactly to ensure proper calibration of the compass.

Compass Declination Zone Set Procedure

The Declination Zone number is used to account for the errors between magnetic North and true North in the vehicle's geographic operating area, and must be set correctly for the compass to display accurate headings.

NOTE: When calibrating / recalibrating the compass, you must select the Declination Zone which corresponds to the geographic location where the compass calibration is being performed. It can be reset later to match the Declination zone where the vehicle will be operating.

For vehicles that regularly operate coast-to-coast or in several different Declination Zones, either choose a Declination Zone in the geographic center of the vehicle's operating area, or change the Declination Zone daily to match the present Declination Zone.



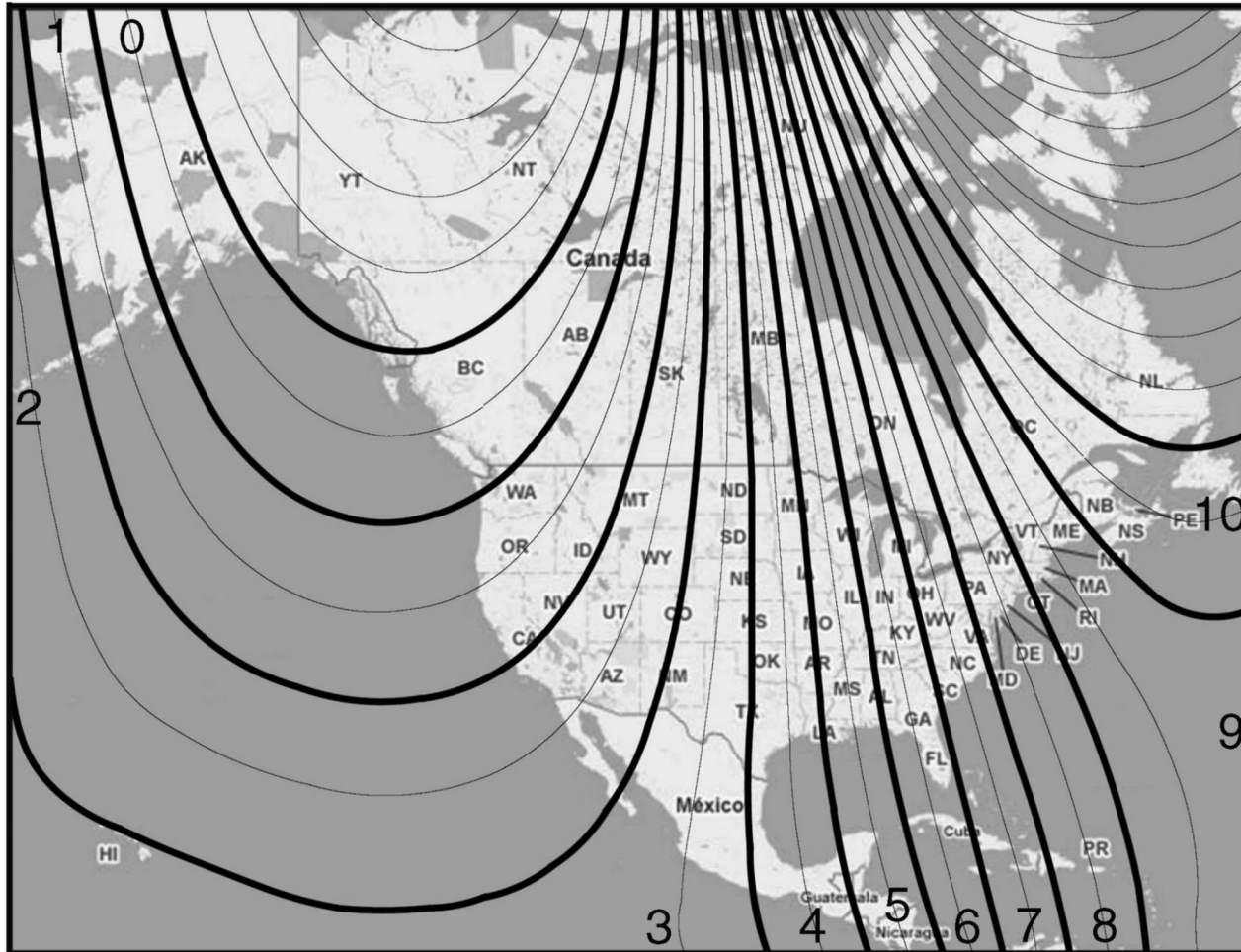

To begin the Declination Zone set procedure, the vehicle must be stopped with ignition key ON. Refer to **Zone Map** for determining the proper Declination Zone number.

Instrumentation

Declination Zone Map







8487229

Step	Procedure	Displayed Message
1	Select Quadrant 2 (lower right) on the display by turning the display control knob either clockwise or counterclockwise.	 <p>(1) (2) * </p> <p>3817049</p>
2	Select the Compass Declination message by pressing and releasing the display control knob until this message appears.	 <p>Compass Declination * </p> <p>3817053</p>
3	Press and hold the display control knob until any Declination Zone number (0 – 10) is displayed.	 <p>Dec Zone 2 </p> <p>3817054</p>
4	<p>Turn the display control knob clockwise or counterclockwise until the desired Declination Zone number is displayed. Refer to Declination Zone Map to determine the proper number for the current geographic location.</p> <p>NOTE: If no Declination Zone number is selected within 15 seconds, the display will return to the Compass Declination message.</p> <p>NOTE: If the compass is being calibrated / recalibrated, the Declination Zone must be set to the Zone number for the location where the compass calibration / recalibration is being performed regardless of the location where the vehicle will eventually operate.</p>	 <p>Dec Zone 6 </p> <p>3817055</p>
5	Press and hold the display control knob until the Compass Declination message appears (this indicates that the new Declination Zone number has been programmed into the compass).	 <p>Compass Declination * </p> <p>3817053</p>

Instrumentation

Compass Directional Calibration Procedure

To begin the Compass Directional Calibration Procedure, stop the vehicle in an area large enough to permit driving in complete circles and perform the following steps:

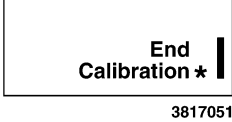
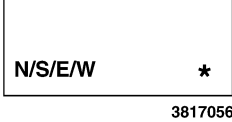

Step	Procedure	Displayed Message
1	Select Quadrant 2 (lower right) on the instrument panel gauge cluster display by turning the display control knob either clockwise or counterclockwise.	 <p style="text-align: right;">3817049</p>
2	Select the Calibrate Compass message by pressing and releasing the display control knob until this message appears.	 <p style="text-align: right;">3817050</p>
3	<p>Press and hold the display control knob until the End Calibration command is displayed.</p> <p>NOTE: IF the End Calibration command will not show up, turn OFF the vehicle, restart it, and return to Step 1.</p> <p>NOTE: The following steps (4 through 6) must be completed within 3 minutes to lock-in the new calibration. Do not press the display control knob or turn the key OFF until these steps are completed or the calibration process will be cancelled.</p>	 <p style="text-align: right;">3817051</p>
4	Immediately following the End Calibration command being displayed, drive the vehicle in three complete circles (during this time the compass display will go blank or have dashed lines present).	 <p style="text-align: right;">3817052</p>

Step	Procedure	Displayed Message
5	Stop the vehicle and wait shortly. The End Calibration message should reappear on the display.	
6	Push and hold the display control knob until the End Calibration command disappears. The calibration should now be complete. IMPORTANT!: Failing to hold the display control knob inward until the End Calibration command disappears will cancel the calibration procedure and you must start over at Step 1.	
7	<p>Test the compass calibration. Turn the vehicle ignition key OFF and then restart the vehicle. Wait 10 seconds for the compass to complete its self test. Drive the vehicle in a circle and note the compass readings:</p> <ul style="list-style-type: none"> • If the lower left quadrant of the Instrument Panel Gauge Cluster Display shows the correct compass / vehicle heading, the compass calibration is now complete. • If the compass readings are incorrect, inspect for correct Declination Zone number, turn OFF the vehicle, restart the vehicle, wait 10 seconds, and perform another circle while periodically noting the compass readings. • If readings are still incorrect, restart the compass calibration procedure. 	

Instrumentation

User Switches

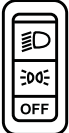
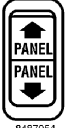
The Instrument Panel Gauge cluster provides locations for six user defined switches. The following table describes the functional details of the standard switch configurations.

Item No.	Item	Description	Switch Indicator Status
Left-Side Optional Push Button Switches			
49	Configured by customer request		
50	Configured by customer request		
51	 0000058012	Headlight / Park Lamp Switch	Go to Lights section
52	 8487054	Instrument Panel Gauge Cluster Dimmer Switch.	Go to Lights section
Right-Side Optional Switches / Indicators			
53	 8487056	Cab Dome Light Switch. Used to turn cab dome light ON and OFF and make it possible to activate / deactivate the dome light coming ON when opening the doors.	
54	Configured by customer request		

Instrument Panel Gauge Audible Alarms



WARNING

To prevent personal injury and / or death, or damage to property, when an alarm sounds, stop normal vehicle operation and determine the source of the alarm condition.

Audible alarms are used in addition to warning indicators and gauges. An audible alarm sounds when a problem exists with one of the vehicle functions. Audible alarms sound when one of the gauges indicates an abnormal condition, or when there is a problem with one of the vehicle systems. When an audible alarm is heard, have the system inspected immediately, and do not operate the bus until the bus is serviced.

Audible Alarms

Alarm Condition	Audible Alarm Pattern	Additional Comments
Fuel Level Gauge low (only alarms on each time key is turned ON)	5 beeps	Gauge warning indicator illuminates.
Voltmeter Gauge out of range reading	5 beeps	Gauge warning indicator illuminates.
Engine Oil Pressure Gauge out of range reading	5 beeps	Gauge warning indicator illuminates.
Engine Coolant Temperature Gauge out of range reading	5 beeps	Gauge warning indicator illuminates.
Transmission Oil Temperature Gauge out of range reading	5 beeps	Gauge warning indicator illuminates.
Diesel Exhaust Fluid (DEF) level low	1 beep	Instrument panel gauge cluster warning indicator illuminates.
Selective Catalytic Reduction (SCR) system fault	1 beep	Instrument panel gauge cluster warning indicator illuminates.
Exhaust Diesel Particulate Filter Regeneration	Continuous tone	Critical soot level.
Auxiliary Air Pressure Gauge out of range reading	5 beeps	Gauge warning indicator illuminates.
Gauge sensor faults	5 beeps	Gauge pointer goes to 6 o'clock position and gauge warning indicator illuminates.

Instrumentation

Audible Alarms (cont.)

Alarm Condition	Audible Alarm Pattern	Additional Comments
Red Stop Lamp illuminates	Repeating single beep	Gauge warning indicator illuminates.
Brake Pressure Indicator illuminates	Repeating single beep	Gauge warning indicator illuminates.
Electrical System Controller fault	10 beeps	CHECK ELEC SYS warning indicator illuminates.
Emergency Exit Alarm	Continuous buzzer	Check for an unlatched emergency exit.
Post Trip Inspection	Repeated single beep, lights flashing then horn honking	Complete the Post Trip Inspection.
Turn Signal Alarm	Continuous tone	Alarm sounds if either turn signal is on for more than one mile. Will not activate when hazard flashers are on.
Low Coolant Alarm	Repeating single beep	Gauge warning indicator illuminates.
Seat Belt Reminder With Seat Belt Monitoring	Repeating single beep	Gauge warning indicator illuminates.

Vehicle Telematics (If Equipped)

Overview

Vehicle telematics allow the customer to create vehicle health reports and remotely update the vehicle Over The Air (OTA). Your vehicle may be equipped with the Telematics Module system.

The vehicle telematics will determine if the vehicle has an outdated calibration and provide the user with the ability to update the calibration. These updates can improve performance, drivability, fuel economy and engine reliability. In addition, these systems relay information to health reports that allow the user to monitor vehicle health and status to help improve uptime. For more information; refer to www.internationaltrucks.com/support/oncommand-connection.

Telematics Module (If Equipped)

The telematics module helps the dealer and user to determine health and status of the vehicle with information such as vehicle health, Global Positioning System (GPS) location, aftertreatment status, Diagnostic Trouble Codes (DTC), warning lamps and basic trip information. The module will have an active data plan when the vehicle is delivered. The module is also able to update the ECM and specific customer programmable parameters to suit preferred driving conditions. This module is equipped with a cellular data connection, GPS satellite connection and is capable of a Bluetooth® connection and connecting to an external Wi-Fi source.

SECTION 4 — DRIVER CONTROLS

Windshield Wiper / Washer System

Wiper Blade Speed

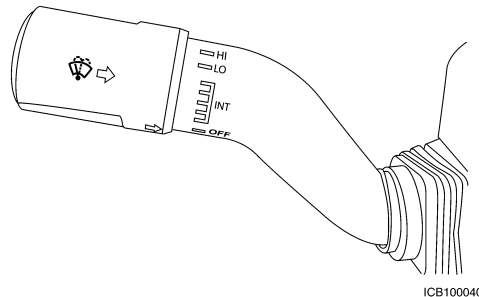

The windshield wiper / washer switch is located on the left-side of the steering column.

Rotate the windshield wiper control to the desired interval, low or high speed position.

The bars are for intermittent wipers. When the wiper control is in the intermittent position, rotate the control upward for faster intervals, and downward for slower intervals.

Windshield Wiper Speed Control

This optional feature forces wipers to slowest intermittent speed when parking brake is set and wipers are left on for a predetermined time.

Windshield Washer

WARNING

To prevent personal injury and / or death, or damage to property, do not use the washers in freezing weather without first warming the windshield with the defrosters; otherwise, the washer solution may freeze on the windshield and obscure your vision, which could cause an accident.

WARNING

To prevent personal injury and / or death, or damage to property, do not use radiator coolant or antifreeze in the windshield washer reservoir. Radiator coolant in the washer reservoir can severely reduce visibility when sprayed on the windshield, which could cause an accident.

Push the control on the end of the stalk inward to activate the washer function. Push and hold for a longer wash cycle. Using the windshield washer function activates the wipers. The wipers automatically cycle to clear the windshield, and also stop automatically after a 5-second cycle.

Turn Signal

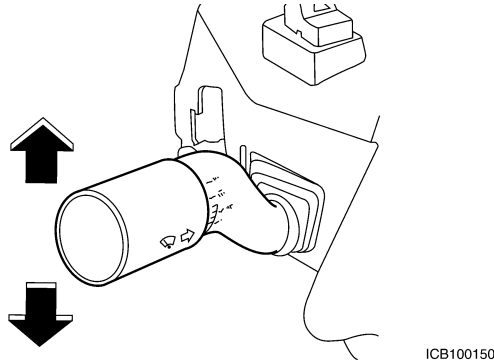

The turn signal switch is located on the left-side of the steering column and is part of the multi-function switch. Move the lever up or down to signal the turning direction. After the turn has been completed, the turn signal automatically cancels.

For additional information about the Turn Signal Multi-Function Switch refer to the **Lights section**.

Steering Wheel and Column

Steering Wheel Controls

NOTE: The location for the entry door and warning flasher switches is the steering wheel, and the right console switch panel.

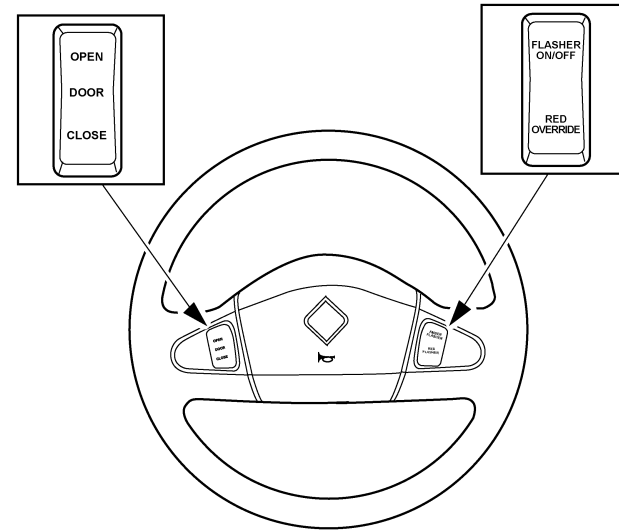

OPEN / CLOSE DOOR button is located on the steering wheel in the left button position.

FLASHERS ON / OFF and RED OVERRIDE button is located on the steering wheel in the right button position.

For more information on these buttons see the **Passenger Control** section.

Steering Wheel Controls (Optional)

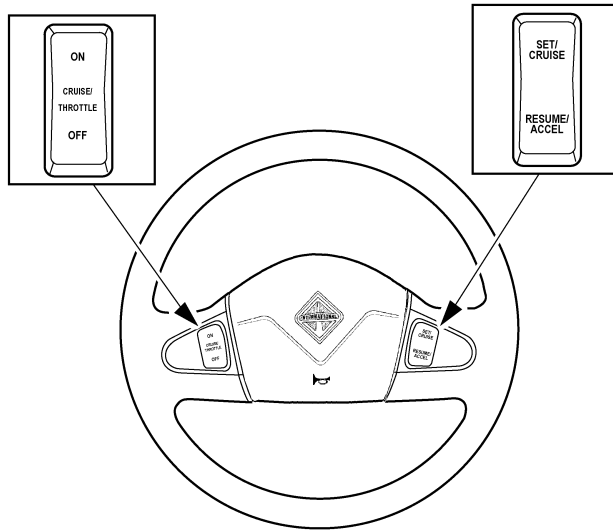

For the correct use of the cruise control switches in this location, refer to the **cruise control procedure** later in this section.



Horn

The horn is a standard electric automotive type and is located in the center of the steering wheel. Push down the horn button to operate it.

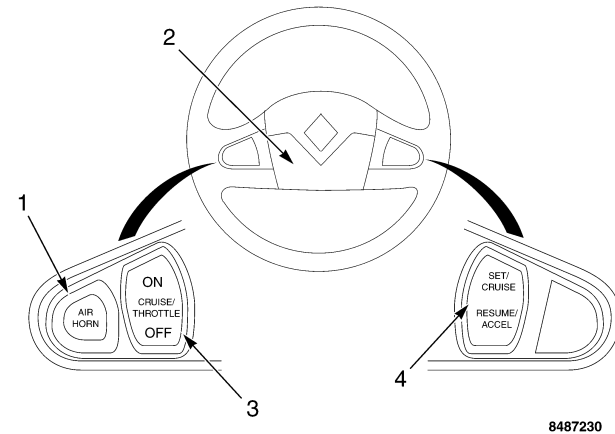

Steering Wheel Controls (Optional)

The steering wheel contains the electric (city) horn, optional air horn control, and cruise / throttle controls.



Callout	Steering Wheel Control	Description
1	 8487234	AIR HORN - Used to activate the air horn.
2	 8487231	HORN - Used to activate the city horn.

Driver Controls

3	 <p>ON CRUISE THROTTLE OFF 8487232</p>	CRUISE / THROTTLE - ON / OFF - Turns the speed control feature ON or OFF. Engine speed does not change when you press the ON position. This control just activates / deactivates the feature. When the OFF position is pressed, the system will be turned OFF.
4	 <p>SET CRUISE RESUME/ ACCEL 8487233</p>	RESUME / ACCEL - Used to resume the desired speed set on the cruise control or accelerate to a higher desired speed. When parked, used to increase idle rpm.

Cruise Control

The cruise control systems for all electronic engines function in a very similar manner. The biggest difference is the minimum and maximum allowable cruise control speeds that will vary from vehicle to vehicle.



WARNING

To prevent personal injury and / or death, or damage to property, do not use the cruise control system when unpredictable driving conditions are present. Such conditions include heavy traffic and / or roads that are winding, icy, snow covered, slippery, wet, or with a loose surface. These conditions may cause wheel slippage and loss of vehicle control.

Basic Functions of Steering Wheel Controls

The CRUISE / THROTTLE - ON / OFF control turns the speed control feature ON or OFF. Engine speed does not change when you press the ON position. This control just activates/deactivates the feature. When the OFF position is pressed, the system will be turned OFF.

The left-side CRUISE / THROTTLE switch has different labels, depending on which feature was ordered. However, they all perform the same function: to turn ON the basic feature.

The two available options are:

- Throttle - used when only throttle or an engine speed control is ordered;
- Cruise / Throttle - used when cruise control and either a hand throttle or an engine speed control are ordered.

The right switch (SET / COAST - RESUME / ACCEL) actually sets and controls the engine speed. However, if the left switch has not been activated, nothing will happen when pushing on this right switch. This switch has the same label in all applications.

Operational Procedures

The following steps will activate and enable each of the four engine speed control features.

Cruise Control – operates like an automotive cruise control.

1. Press the ON position of the CRUISE / THROTTLE - ON / OFF steering wheel control.

2. Bring the vehicle to the desired operating speed (above 35 mph [56 km/h]), and then push the SET / CRUISE position of the steering wheel control.
3. Once in the cruise mode the right side SET / CRUISE – RESUME / ACCEL switch can be used to increase or decrease vehicle speed by pressing and holding the RESUME / ACCEL to increase or the SET / CRUISE to decrease vehicle speed.
4. A slight tap on the brake or clutch pedal will deactivate the cruise but holds the selected speed in memory. To return to this speed, just press RESUME / ACCEL.
5. When you press the OFF (left) position of the CRUISE / THROTTLE - ON / OFF switch, or if the vehicle is shut OFF, the selected speed setting is canceled.

Throttle

This feature is ordered to provide variable engine speed control primarily for operation of PTO powered equipment. It uses the same Cruise controls as described below.

1. Press the CRUISE / THROTTLE - ON / OFF steering wheel control to ON.
2. Press SET / CRUISE on the steering wheel control.
3. Press and hold RESUME / ACCEL to increase engine speed until the desired engine speed is obtained. Or, you can repeatedly press and release RESUME / ACCEL to increase the speed in small increments.
4. To change from this initial setting, use the appropriate control to raise or lower the engine speed as you would

in the cruise control mode. SET/CRUISE reduces engine speed and RESUME / ACCEL increases engine speed.

5. Press the OFF position of the ON / OFF control to turn the throttle off and return the engine to idle.

Stationary Variable Speed Control (12VXT)

This feature is ordered to provide variable engine speed control primarily for operation of PTO powered equipment. It operates the same as the Cruise / Throttle controls discussed above.

Stationary Pre-Set Speed Control (12VXU)

1. To activate this feature, press the ON position on the left-side CRUISE / THROTTLE - ON / OFF switch.
2. When ordered, this feature can provide two different predetermined speeds, which are selected with the SET / CRUISE or RESUME / ACCEL positions. You need to know which position to use for your specific operation. Press the right side SET / CRUISE or RESUME / ACCEL switch for the desired pre-set speed.
3. First, press the switch that selects one of the desired speeds.
4. To select the other speed, press the other switch. The engine will immediately return to idle.
5. You must push the switch a second time to go to the second speed. This is done to protect equipment from being inadvertently operated at the wrong speed.

Driver Controls

Mobile Variable Speed Control (12VXV)

Operates the same as cruise control, except the engine speed is accurately controlled instead of vehicle speed. The truck could be operated in one of several gears, but the truck is limited to a maximum of 20 mph (32 km/h), or any pre-set lower speed down to 3 mph (5 km/h).

Adjustable Tilt Steering Column



WARNING

To prevent personal injury and / or death, or damage to property, do not adjust the steering column while the vehicle is moving. It could suddenly or unexpectedly move, causing the driver to lose control of vehicle.



CAUTION

To prevent property / vehicle and / or engine component damage, do not lubricate the tilt mechanism.

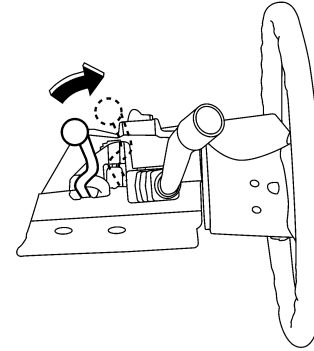

ICB100042

The optional adjustable tilt steering column allows you to pull the tilt steering control toward you and move the steering wheel up or down. Hold the control while adjusting the wheel to the desired position. Release the tilt steering control to lock the column in position.

Left Console Switch Panel

Rocker Switches and Their Functions

NOTE: Due to differences in state and local requirements and customer preferences, the location and arrangements of the controls and switches on the console switch panels may be different than illustrated. Some switch positions may be empty, while other rows may have only one switch. Switches are installed in the same location unless precluded by state regulations. Before reading this section of the manual, sit in driver's seat and become familiar with the location of the controls and switches in this bus.

NOTE: Your bus may not be equipped with all switches listed.



NOTE: Use of the cup holder during operation of the vehicle should be in accordance with state regulations, school district guidelines and bus providers operating policies.

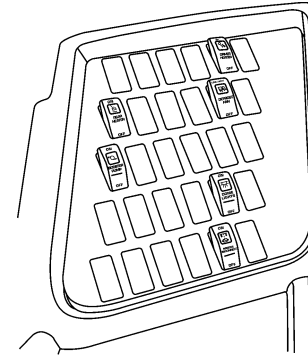



The left console switch panel contains the controls for bus heaters and defrosters, destination sign, and other standard and optional bus body controls.

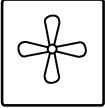

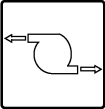
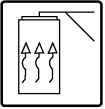
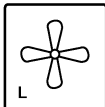

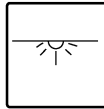

ICB100043

Driver Controls

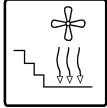
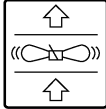

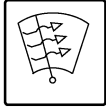
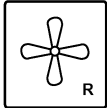
Switch Description	Switch Icon
DRIVER HEATER / DEFROST: Turns heater / defrost blower motor to HIGH / LOW / OFF.	 <p>DRIVER HEATER DEFROST 3813093</p>
REAR HEATER: Turns heater blower HIGH / LOW / OFF.	 <p>REAR HEATER ICB900002</p>
BOOSTER PUMP: Turns ON / OFF coolant pump in heating system.	 <p>BOOSTER PUMP ICB100163</p>
HEATED MIRROR: Turns heating element behind outside mirror glass ON / OFF.	 <p>HEATED MIRROR ICB100165</p>
LEFT FAN: Turns HIGH / LOW / OFF driver's defog fan above windshield.	 <p>LEFT FAN ICB900007</p>

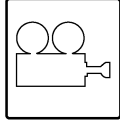
DRIVER DOME: Turns ON / OFF driver side lights.	 <p>DRIVER DOME ICB100172</p>
DOVE LIGHTS: Turns ON / OFF interior side lights.	 <p>DOVE LIGHTS ICB100173</p>
NOISE SUPP: Disconnects power to all noise generating devices.	 <p>NOISE SUPP 3813030</p>
LIFT SWITCH: Turns wheelchair lift power ON or OFF.	 <p>LIFT 3813031</p>
MIDSHIP HEATER: Turns heater blower motor to HIGH / LOW / OFF.	 <p>MIDSHIP HEATER ICB900003</p>

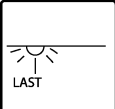
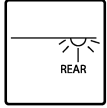
<p>STEPWELL HEATER: Turns the Stepwell Heater ON / OFF.</p>	 <p>STEPWELL HEATER ICB900011</p>
<p>POWER VENT: Turns ON / OFF power to exhaust vent.</p>	 <p>POWER VENT ICB100164</p>
<p>STOP ARM HEATER: Turns ON / OFF stop arm heater.</p>	 <p>STOP ARM HEATER ICB100162</p>
<p>HEATED WIPER BLADE: Turns Heated Wiper Blade ON / OFF.</p>	 <p>HTD WIPER BLADE ICB100175</p>
<p>RIGHT FAN: Turns right front windshield defog fan HIGH / LOW / OFF.</p>	 <p>RIGHT FAN ICB900004</p>

<p>CAMERA: Turns ON / OFF internal (Passenger-viewing) camera.</p>	 <p>CAMERA ICB100167</p>
<p>DESTINATION: Turns ON / OFF illumination for destination window.</p>	 <p>DSTNATN SIGN ICB900005</p>
<p>STROBE LIGHT: Turns ON / OFF top strobe light.</p>	 <p>STROBE LIGHT ICB100169</p>
<p>LAST DOME: Turns ON / OFF last dome light.</p>	 <p>LAST DOME ICB100170</p>
<p>REAR DOME: Turns ON / OFF rear half dome lights.</p>	 <p>REAR DOME ICB100174</p>

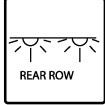
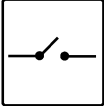
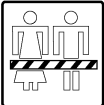
Driver Controls

<p>REAR ROW DOME: Turns ON / OFF rear row lights.</p>	 <p>REAR ROW DOME ICB100171</p>
<p>MASTER FLASHER: Turns ON / OFF system power for the warning indicator system.</p>	 <p>MASTER FLASHER ICB100176</p>
<p>CROSSING GATE (CANCEL): Switch that blocks extension of crossing gate.</p>	 <p>CROSSING GATE ICB100177</p>
<p>STOP ARM STROBE: Turn the optional strobe ON / OFF on the stop arm.</p>	 <p>STOP ARM STROBE ICB900008</p>

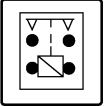
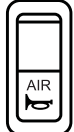
<p>STOP ARM CANCEL: Momentary switch retracts Stop Arm / Crossing Gate, turns on Chime, while RED warning flashers are on.</p>	 <p>STOP ARM CANCEL ICB100179</p>
<p>MASTER DISCONNECT: Controls power to designated body circuits, ignition switch, or rocker switch operations.</p>	 <p>MASTER DISCONNECT ICB100180</p>
<p>AIR HORN: Controls solenoid that turns optional Air Horn ON or OFF.</p>	 <p>0000058013</p>

Power Outlet

The optional power outlet is located inside the storage compartment. The power outlet supplies a 12-volt power supply for driver accessories, such as cellular phones and two-way radios.

Transmission, Parking Brake, and Ignition Switch Panel

Before reading this section of the manual, sit in driver's seat and become familiar with the location of these controls.

The Transmission / Parking Brake / Ignition Switch Panel provides the mounting for the automatic transmission shifter, the knob to engage / disengage the parking brake and the ignition switch.

For instruction on the operation of the components on this panel refer to the **Operation** section.

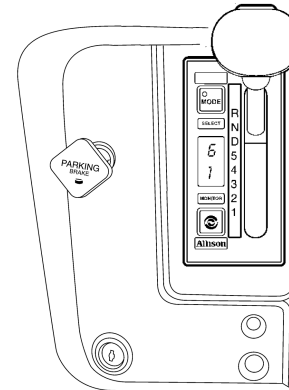
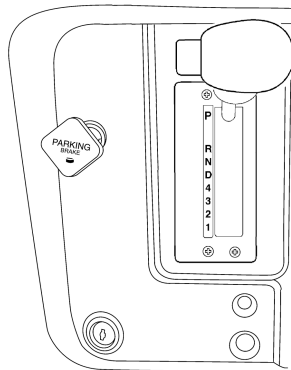
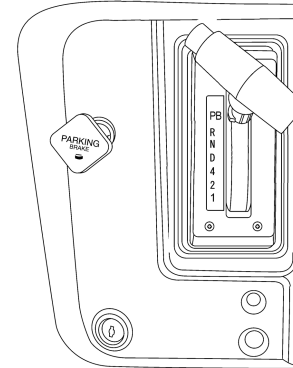

Driver Controls

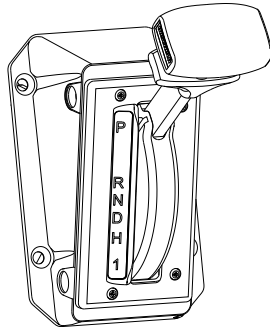
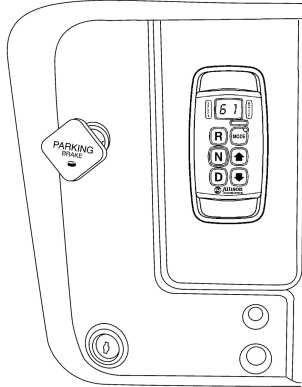

0000387974

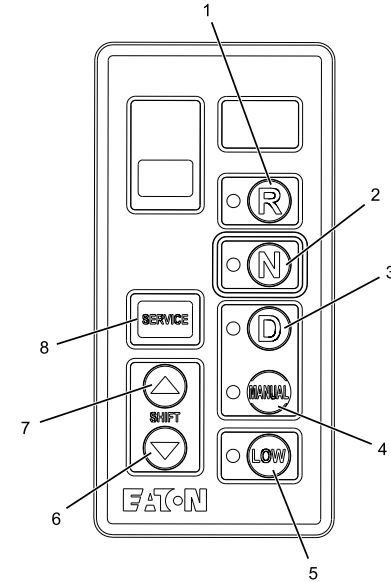

1. Reverse button
2. Neutral button
3. Forward gear selector button
4. Hold button
5. Low gear button
6. Downshift button
7. Upshift button
8. Service indicator

0000387982

Right Console Switch Panel

Rocker Switches and Their Functions

NOTE: Due to differences in state and local requirements, the location and arrangements of the controls and switches on the console switch panels may be different. Some switch positions may be empty, while other rows may have only one switch. Switches are installed in the same location unless precluded by state regulations. Before reading this section of the manual, sit in driver’s seat and become familiar with the location of the controls and switches in this bus.

NOTE: Your bus may not be equipped with all the switches listed.

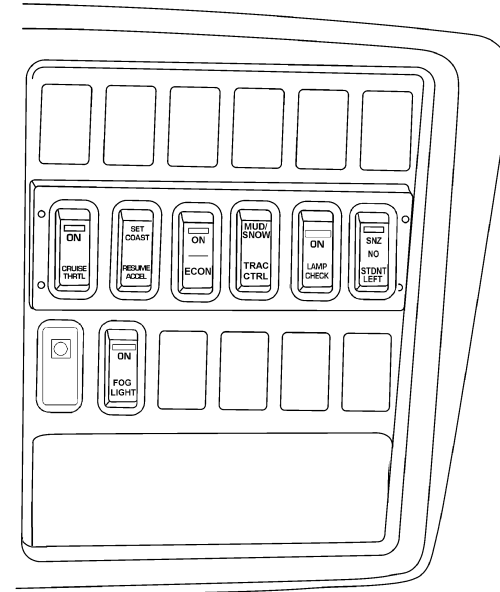



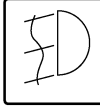
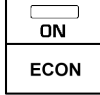
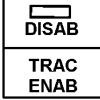
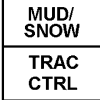

3813096

Switch Description	Switch Icon
CRUISE SWITCH: Turns the cruise control system ON and OFF.	

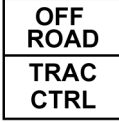
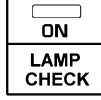
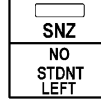
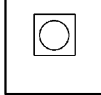
Driver Controls

<p>SET COAST / RESUME ACCEL SWITCH: sets and controls the engine speed.</p>	 <p>THROTTLE ICB100185</p>
<p>FOG LAMP SWITCH: Turns the fog lamps ON and OFF.</p>	 <p>FOG LAMP ICB100187</p>
<p>ECON / ON SWITCH: Turns transmission Economy mode ON and OFF.</p>	 <p>ECON MODE</p>
<p>DISAB / TRAC ENAB Switch: Turns Traction Control system ON or OFF (if equipped).</p>	 <p>ATC 3813036</p>
<p>MUD / SNOW) / TRAC CTRL Switch: Controls amount of ATC action of the Traction Control system (Hydraulic Brake chassis) (if equipped).</p>	 <p>ATC 3813037</p>

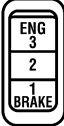
<p>OFF ROAD / TRAC CTRL Switch: Controls amount of ATC action of the Traction Control system (Air Brake chassis) (if equipped).</p>	 <p>ATC 0000466363</p>
<p>ON / LAMP CHECK: Initiates exterior lamp test during Pre Trip inspection.</p>	 <p>LAMP CHECK 3813038</p>
<p>SNZ / NO STDNT LEFT: Initiates delay of Post Trip inspection system activation.</p>	 <p>SNOOZE 3813039</p>
<p>LIFT Door Indicator: GREEN indicator flashes to indicate that Lift door is opened (if equipped).</p>	 <p>LIFT 3813040</p>
<p>ENG BRAKE – ON / OFF: Turns engine compression brake ON / OFF.</p>	 <p>8487110</p>

<p>ENG BRAKE 1 / 2 / 3: A three position switch that selects the amount of engine braking (1 = Low, 2 = Medium, 3 = High)</p>	 <p>8487103</p>
<p>EXH BRAKE – ON / OFF: Turns engine exhaust brake ON or OFF.</p>	 <p>8487268</p>
<p>PEDAL ADJ – FWD / BACK: Allows forward / upward and back / downward repositioning of power-adjustable pedals when key is in the ON position, the park brake is set, and the transmission is in neutral or park.</p>	 <p>0000433084</p>

Cruise Control

Operation



WARNING

To prevent personal injury and / or death, or damage to property, do not use the cruise control system when unpredictable driving conditions are present. Such conditions include heavy traffic and / or roads that are winding, icy, snow covered, slippery, wet, or with a loose surface. These conditions may cause wheel slippage and loss of vehicle control.

NOTE: The right console switch panel is the standard location for the cruise control switches. These switches may be located on the steering wheel as an available option, moving the entry door controls and pupil warning indicator to the right console switch panel.

The electronic engine vehicle speed controls are activated by the switches located on the console switch panel.

The left ON / OFF switch turns the control feature ON or OFF. The right switch (SET / COAST — RESUME / ACCEL) sets and controls the engine speed.

1. Press the ON position on the ON / OFF rocker switch to activate the cruise control feature.
2. Press the SET position on the rocker switch after reaching a speed of at least 35 mph (56 km/h) to set the cruise speed.

Driver Controls

3. Push and hold the RESUME / ACCEL to increase your set speed, or the SET / COAST to decrease your set speed.
4. A slight tap on the brake pedal deactivates the cruise. To return to this speed, press the RESUME / ACCEL position switch.
5. Push the OFF position on the switch to cancel the previous speed setting. The previous speed setting is also cancelled when the vehicle is turned OFF.

Mirror Adjustment



WARNING

To prevent personal injury and / or death, or damage to property, use patience and always check the overall field of vision when unloading, as some children could be outside the field of vision. Do not move your bus until you have confirmed the location of every child and confirmed that they are clear.



WARNING

To prevent personal injury and / or death, or damage to property, mirrors are not a substitute for exercising care in operating the vehicle. Mirrors must be properly adjusted for each driver and the driver must be aware of the limitations on the viewing area that exists even when the mirrors are properly used.



WARNING

To prevent personal injury and / or death, or damage to property, only use the crossview mirrors to view pedestrians while the bus is stopped. Images in such mirrors do not accurately show other vehicle locations.



WARNING

To prevent personal injury and / or death, or damage to property, check to see that area behind vehicle is clear of people, animals, and objects before backing up. Use a spotter whenever possible and always keep that person in sight. If so desired, backup alarms are available through your IC Bus® dealer. However, they are never a substitute for the above procedures.

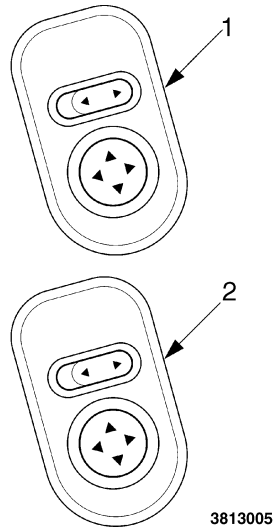

1. Left- / Right-side flat mirror adjustment switch
2. Left- / Right-side convex mirror adjustment switch

The optional mirror adjustment controls are located on the left-side console control panel. The switches with the left and right directional arrows control which side will be adjusted. To adjust the left-side mirror, ensure the switch is in the left position. To adjust the right-side mirror, ensure the switch is in the right position.

Before driving the bus, check the mirror adjustment. The mirrors enhance visibility and assist safe vehicle operation. Ensure you can see the entire front of the bus using the cross view mirrors. Use the rear view mirrors to see both sides of the bus, and at least four bus lengths behind the bus. Use the following steps to adjust the mirrors before you operate the bus.

1. Adjust the driver's seat to the desired position, and observe the view through all outside mirrors to enhance visibility in all directions
2. Look through the right-side flat driving mirror and ensure that the top of the side windows are visible in the upper edge of the mirror, and that the right-side of the bus body is visible in the inside edge of the right-side flat mirror.
3. Look through the right-side convex driving mirror and ensure that the view in the top of the convex mirror overlaps the view covered by the right-side flat driving mirror, and that the right-side of the bus body is visible in the inside edge of the right-side convex mirror.
4. Look through the left-side flat driving mirror and the left-side convex driving mirror and observe that the views are the same as described for the right-side mirrors. Refer to Steps 2 and 3.
5. Look through and adjust the cross view mirrors to ensure that there is complete visibility around both sides and the front of the bus.

SECTION 5 — LIGHTS

Headlight Switch and Panel Lighting Control

Headlight Switch

These switches are part of the Instrument Panel Gauge Cluster and located below the Instrument Gauges.

The headlights, parking, marker and tail lights are controlled by the three-position PARK / HEADLIGHT rocker switch. This switch functions even when ignition key is turned OFF.

- Place the switch in the top position to turn ON the headlights, parking, marker and tail lights. The Instrument Panel Gauge Cluster illuminates when the park or headlights are turned ON.
- Place the switch in the middle position to turn ON the parking lights, marker lights and taillights.
- Place the switch in the lower position to turn OFF the lights.

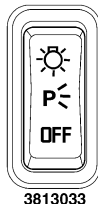

Headlight Warning Buzzer Feature: This optional buzzer sounds when headlight switch is ON and ignition switch is in the OFF position.

Daytime Running Lights Feature: This optional feature provides for vehicle headlights to be turned ON when engine is running and headlight switch is in OFF position.

Optional Headlight Feature (08WPY): Provides for headlights, tail lights, park / marker lights, and Instrument Panel Gauge Cluster lights to function with ignition switch ON and headlight switch OFF.

Optional Headlight Feature (08WRU): Provides for headlights, tail lights, park / marker lights, and Instrument Panel Gauge Cluster lights to function when the engine is running and headlight switch OFF.

Automatic Headlights

The optional automatic headlights feature automatically turns on headlights at low ambient light levels. This feature can be overridden, however, by pressing the push button switch in the lower left switch pack in the Instrument Panel Gauge Cluster.



Panel Lighting Control

The Panel rocker switch controls the panel lighting brightness. Press the upper portion of the rocker switch to increase the brightness. Press the lower portion of the rocker switch to dim the brightness.

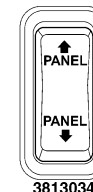

Interior (Dome) Lights

For control of inside lights, see the Driver Controls section.

Hazard Warning Light Switch

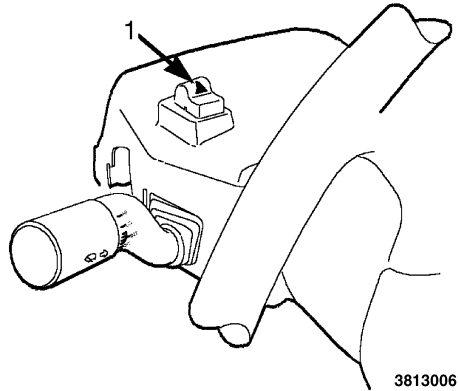

1. Hazard Warning Light Switch

Use the hazard warning light switch in an emergency to warn traffic of vehicle breakdown, approaching danger, the vehicle is in tow, or is operating at a reduced speed. The hazard warning lights can be operated with the ignition in any key switch position.

Press the button to activate all hazard flashers simultaneously.

Press the button again to turn the flashers OFF.

Turn Signal Switch

The turn signal switch is mounted on the left-side of the steering column below the steering wheel. The GREEN directional indicator lights which are activated by the turn signal switch, are located on the instrument panel.

Signaling for a Turn

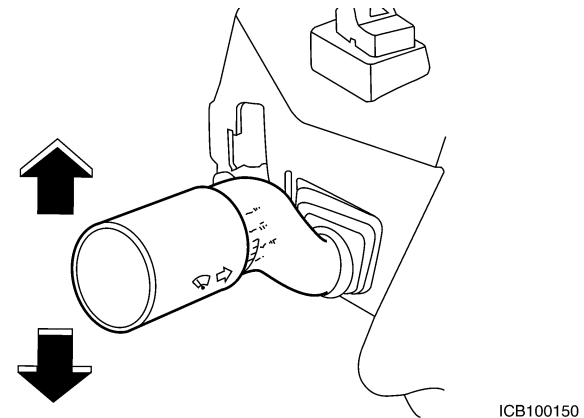

Move the turn signal lever up or down to the full turn position which is past the point of resistance. The turn signal automatically cancels if the steering wheel is turned through a large enough degree.

Lane Change

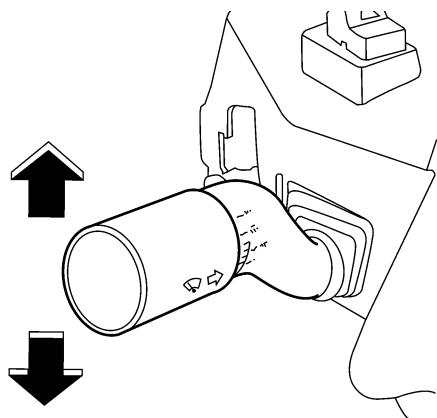

ICB100150

Some switches include a lane change feature which allows you to signal your intention to change lanes without locking the switch into the full turn position. Move the turn signal lever, up or down, to the point where resistance to movement is felt. The turn signal lever returns to the OFF position when released.

HIGH / LOW Beam

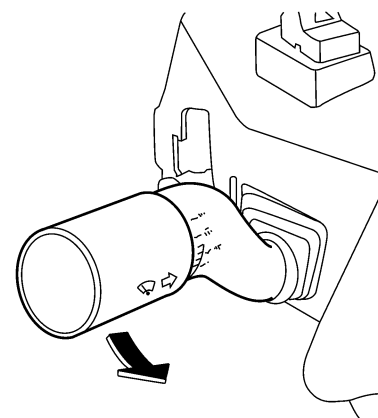

ICB100154

Pull the turn signal lever past the click position, the lights switch to high beam position. Pull again to return to low beam.

Lights

Strobe Light

The optional strobe light comes on automatically unless operated by a separate switch. Check your state regulations on strobe light use.

Exterior Lamp Check

Switch Location

The switch to activate and deactivate the exterior lamp check system is one of the right-side user switches located below the Instrument Panel Gauge Cluster.

Function

The exterior lamp check is a feature that allows the driver to conduct the exterior lamp check by themselves. The exterior lamp check is included in the pretrip inspection section of this manual. While the system is active, the driver can exit the bus and visually inspect all lights on the exterior of the vehicle for proper operation.

Activation

To activate the exterior lamp check:

- Turn the key to the ON or Accessory (ACC) ignition position.
- All lights that will be checked must be turned OFF.
- The parking brake must be set.
- Place the exterior lamp check switch in the ON (up) position. The exterior lamp switch ON indicator will then illuminate GREEN.

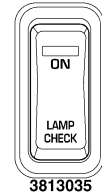

Deactivation

To deactivate the system, do any one of the following:

- Press the exterior lamp switch to the OFF (down) position.
- Move the ignition switch to the OFF, or ACC position.
- Manually turn ON lamps being checked with this feature.
- Release the parking brake.

When the exterior lamp check system is deactivated the GREEN indicator on the switch will turn ON.

SECTION 6 — PASSENGER CONTROL

Door Opening / Closing

Opening / Closing



WARNING

To prevent personal injury and / or death, or damage to property, ensure that each child, and all of their clothing, backpacks, bookbags and other belongings are clear of the vehicle before the door is closed and the bus operated. Consult with local and state authorities for specific procedures that may apply for children entering or exiting buses.

NOTE: Due to various state and local requirements, the location of the entrance door OPEN / CLOSE switches shown may be different than your vehicle.

The entrance door OPEN / CLOSE button is located on the steering wheel in the left button position.

Press the top of the button to open the entrance door.

Press the bottom of the button to close the entrance door.

Two-Position Door Switch

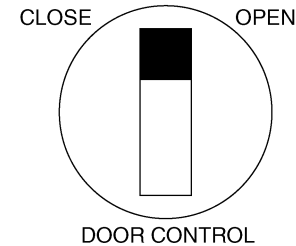

ICB900012

The optional two position door switch is located on the left-side or right-side console switch panel.

With the ignition in the accessory or ignition position, the entrance door can be opened by moving the switch to the OPEN position.

With the ignition in the accessory or ignition position, the entrance door can be closed by moving the switch to the CLOSE position.

Passenger Control

Three-Position Door Switch

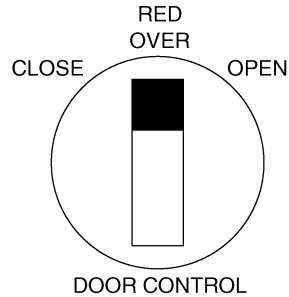

ICB900013

The optional three position door switch is located on the left-side or right-side console switch panel.

With the ignition in the accessory or ignition position, the entrance door can be opened by moving the switch to the OPEN position.

With the ignition in the accessory or ignition position, the entrance door can be closed by moving the switch to the CLOSE position.

Moving the switch to the RED OVER position will start the RED flashers (assuming the master flasher switch is ON) but will not open or close the entrance door.

Opening the Entrance Door

Opening the Entrance Door Manually



To prevent personal injury and / or death, or damage to property, for outward opening doors, when the door Manual / Automatic switch is in the manual position, do not allow anyone to lean against the entrance doors, as they will open, allowing a person to fall out of the bus. The manual position is only to be used in Emergency or Service Conditions.

Electric-Actuated Door

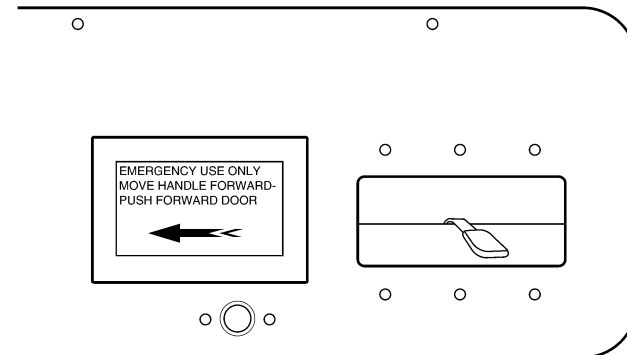

ICB100508

The emergency release for the electrically actuated door is located behind the access panel over the entrance door. To release the electrically actuated door, grasp the handle and move forward (left).

Air-Actuated Door

The emergency release for the air actuated door is located on the right side of the instrument panel. To release the air actuated door, move the toggle switch from NORMAL to EMERGENCY.



Traffic Warning System

The Traffic Warning system alerts both oncoming and following drivers when the bus is preparing for safety stops, such as railroad crossing stops, or when loading and unloading passengers. The system consists of an eight-lamp RED and AMBER warning indicator system and an optional electronic safety messages sign. Both of these systems will be described below.

Electronic Safety Messages

The electronic messaging system is an electronic rear facing LED sign that provides two distinct safety messages to alert drivers when the bus is stopping or stopped. When the amber warning lights are activated, the alternating **Caution - Stopping** LED message is flashes.



3813007

When the RED warning lights are activated and the stop arm is deployed, the alternating **Stop – Do Not Pass** LED message flashes. See the description of the eight-lamp AMBER and RED warning lights below.



3813008

Eight-Lamp AMBER and RED Warning Lights

The eight-lamp AMBER and RED warning system is made up of four amber (two front and two rear), and four RED (two front and two rear) flashing lights, and is part of the warning flasher system.

Passenger Control

The AMBER warning lights alert the public of the intent to stop and load / unload students onto / from the bus. The RED warning lights and the stop arm are intended to warn the public that students are boarding or leaving the bus.

The warning indicator control is located on the right-side of the steering wheel.

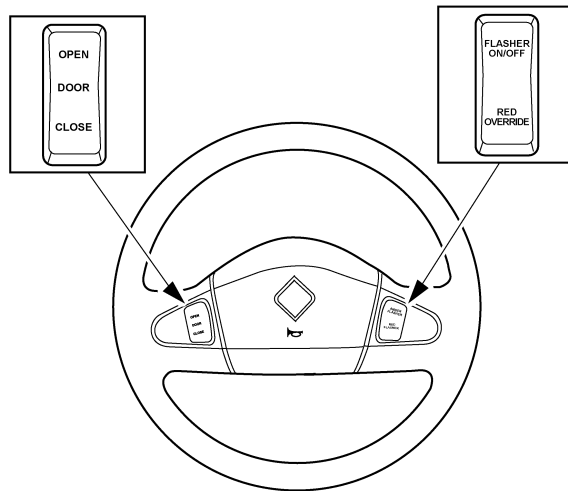

Optional Rocker Switches

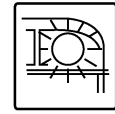

FLASHER
LIGHT

ICB900000

NOTE: These switches can be located on the left-side or right-side console switch panel.



OVER-
RIDE

ICB900001

NOTE: These rocker switches are an optional alternative to the steering wheel controls. When this option is chosen, the cruise / throttle switches move to the steering wheel location.

Sequential System

Press the FLASHER ON / OFF button to engage the AMBER warning lights.

The AMBER warning lights change automatically to the RED warning lights when the entrance door is opened.

The RED warning lights will deactivate when the door is closed and the vehicle travels faster than a preset road speed parameter.

The RED warning lights will deactivate when the door is closed when the bus is not moving (if equipped).

NOTE: If the entrance door is reopened without pressing the FLASHER ON / OFF or the RED OVERRIDE buttons, the RED warning lights will not activate.

Press the RED OVERRIDE button twice to turn OFF the RED warning lights while the door is open and the bus is not moving. The RED warning lights can also be turned OFF while traveling at a speed lower than the preset road speed parameter with the door closed.

Non-Sequential System

With the master flasher switch in the ON position, press the FLASHER ON / OFF button to engage the AMBER warning lights. (If the master switch is not turned ON, there will be no activation of the lights or stop arm.)

The AMBER warning lights change automatically to the RED warning lights when the entrance door is opened.

The RED warning lights will deactivate when the doors are closed.

NOTE: If the door is reopened, the RED lights will reactivate without pressing the FLASHER ON / OFF or the RED OVERRIDE buttons.

To turn OFF the RED warning lights while the door is open and the bus is not moving, press the RED OVERRIDE switch twice, or turn OFF the master flasher switch.

WIG WAG Warning System

The optional Wig Wag is a device for flashing the right and left headlights alternately at a preset rate of about 75 times per minute. If the low beams are on, the high beams will alternate and vice versa. If the driving lights are on, the low beams will alternate.

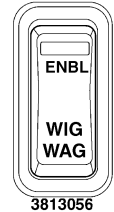

Flashing Stop Arm

Used to warn the public that students are boarding or leaving the bus.

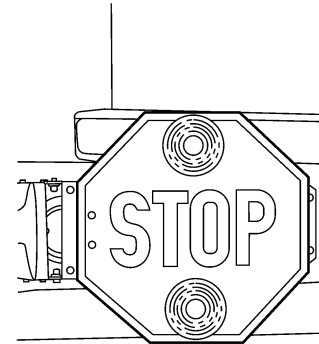

ICB100155

Crossing Gate

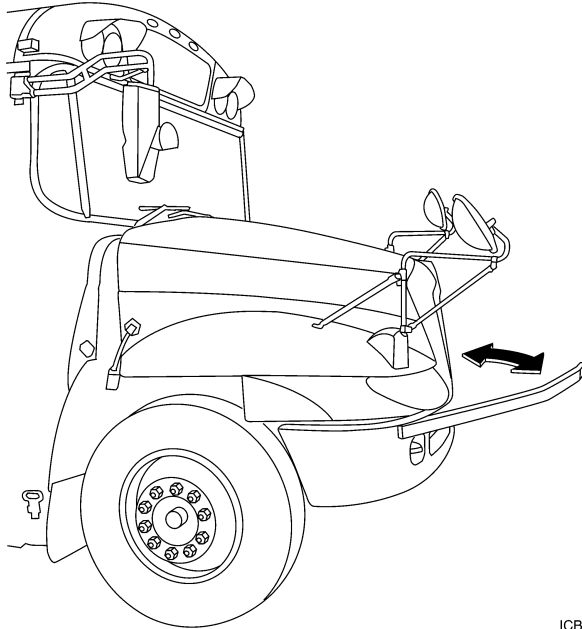

ICB100511

The crossing gate extends when the RED warning lights are on to ensure that students do not cross too close to the front of the bus and out of the view of the driver.

NOTE: The illustration is for reference only and may differ from the actual vehicle.

Driver Visual Warning Lights and Indicators

The driver's visual warning lights, located in the Instrument Panel Gauge Cluster, indicate the operation of the eight-lamp warning system (either AMBER or RED), the wheelchair lift door indicator, and other optional equipment.

Each indicator only comes on when the respective light or switch is activated.

EXTERIOR LIGHT MONITOR (OPTIONAL):

The light monitor is mounted in the overhead console panel.

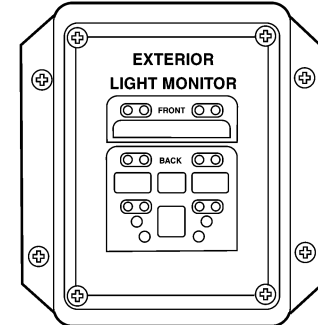

ICB100159

Audible Warning Buzzer

The audible warning device buzzer is activated when the rear emergency door, roof hatch (if equipped with a buzzer), kickout windows, or side emergency doors are open with the ignition switch in the ON or ACC (Accessory) position.

Post-Trip Inspection (No Student Left Behind)

System Purpose

It is the driver's responsibility to check for children who may be left on the bus at the end of every trip. The Post Trip Inspection (No Student Left Behind) System is intended to be an aid to the driver to ensure that this responsibility is not inadvertently omitted. The system provides audible and visual alerts when the bus ignition is turned OFF at the end of a trip.

System Function

Any time the ignition key is in the ON position and the RED flashers have been turned ON **and** the door is opened (or is already open), the system will be automatically activated. Once the system is activated, it will trigger the vehicle alarm when the ignition is in the OFF position for greater than half a second. At this time, the Instrument Panel Gauge Cluster alarm will begin to beep and the headlights will flash to remind the driver to complete the Post Trip Inspection (No Student Left Behind) deactivation process. **If the deactivation is not completed within 60 seconds, the horn will also begin to honk.**

System Activation

Normal student pickup / drop off operation of the bus will automatically activate the system. For test purposes, however, this can also be simulated by the following procedure:

1. Start the bus or simply turn the ignition key to the ON position.

2. Activate the RED flashers.
3. Open the door (if not already opened).
4. Close the door to turn OFF the RED flashers.
5. The Post Trip Inspection system will then be triggered (Instrument Panel Gauge Cluster will beep and headlights will flash) when the ignition switch is turned to the OFF position for longer than half a second.

System Deactivation

To deactivate the Post Trip Inspection (**No Student Left Behind**) system once the system is triggered, the following steps must be performed within 60 seconds (to avoid horn honking):

1. Turn the key to the ACC (Accessory) position and set the parking brake.
2. Close the door (if not already closed).
3. As you proceed to the rear of the bus, check for children that may be still on the bus. When you reach the rear of the bus, lift then lower the rear emergency door lever. If this bus is equipped with the optional post trip inspection RESET BUTTON (located above the last window on the driver-side) press and release this push button.
4. The system is now deactivated, and the Instrument Panel Gauge Cluster beep, headlights and horn should now be OFF.
5. Move the key to the OFF position. Remove the key if exiting the bus.

Passenger Control

Snooze Mode

This function allows the driver to temporarily disable the No Student Left Behind system activation, and is called the Snooze mode. The purpose is to allow passengers to disembark the vehicle without the No student Left Behind system triggering the vehicle alarm.

This alternate operation allows the driver to turn OFF the engine while passengers enter or leave the vehicle.

Snooze Mode Initiation Procedure. To initiate the Snooze feature, proceed and observe the following:

1. First, with the engine turned OFF, place the ignition switch to the ON or ACC position.
2. Press and release the SNZ / NO STDNT LEFT switch to the SNZ position.
3. The switch indicator will turn ON, indicating that the Snooze mode is active. This places the (No Student Left Behind) system in Snooze (inhibits triggering of the vehicle alarm) for a predetermined time (default 20 minutes).
4. In the last 60 seconds of the timed Snooze period, the switch indicator will begin to flash, and will continue to flash for the remainder of the time period.

5. After the Snooze period, the switch indicator will turn OFF, and the No Student Left Behind system will be re-activated.

NOTE: The Snooze function can be turned OFF, before the snooze time-out period, by placing the ignition switch to the OFF position.

BUS-SCAN® 100 System

On the BUS-SCAN® 100 System control box, verify that the system is in the ACTIVE mode and that the RED active LED is illuminated with the ignition switch in the ON position.

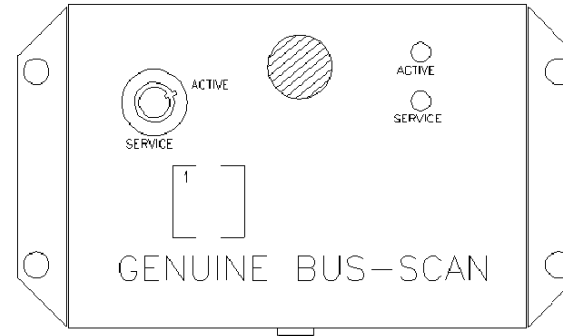

1. Turn ignition OFF.
2. The alarm on the BUS-SCAN® control box will sound and the **Right Panel pilot light** will turn ON.
3. Walk to rear of bus and press the deactivation switch mounted on the left-side light bar. If the deactivation switch is not pressed within 60 seconds, the bus horn will begin to honk. The horn can be silenced by turning ignition switch ON, then OFF.

Unloading Students With Engine OFF

The BUS-SCAN® 100 System provides for the safe unloading of students by allowing the driver to have the engine turned OFF and the ignition switch in the ACC position. This will turn the system OFF (indicated by the ACTIVE LED not illuminated). Children can then be helped off the bus without fear of accidental vehicle movement.

Wheelchair Lift Operation

For operation of the optional wheelchair lift (including the Lift Door), refer to the **Manufacturer Operation Manual**.



WARNING

To prevent personal injury and / or death, or damage to property, always set the parking brake when operating the wheelchair lift, or unexpected and sudden vehicle movement may occur.

Wheelchair Lift Interlocks – Extending

Read the following before operating the wheelchair lift.

The wheelchair lift system for these buses are designed with interlocks that require the vehicle to be completely stopped with the transmission out of gear and the parking brake applied, before the wheelchair lift system can be fully utilized.

Power will not be supplied to the wheelchair lift mechanism unless all of the following steps have been performed (**this is true even with the optional Lift switch in the ON position — See Driver Controls section for the switch description**).

Also, refer to the **Brake and Transmission sections** for wheelchair lift interlocks.

1. Ensure that the ignition switch is in the ON or ACC (Accessory) position.
2. Place transmission shift lever in Park (P) or Neutral (N) position.
3. Apply parking brake. The Instrument Panel Gauge Cluster PARK indicator will turn ON.
4. Open the wheelchair lift door. The optional GREEN indicator (in left-side control panel) will flash as long as lift door is opened.

Passenger Control

NOTE: An optional exterior light is provided, which is mounted below the Lift door and activated by opening lift door. It is used to light up the area while the wheelchair lift is in operation.

The wheelchair lift can now be operated (according to the manufacturer's Operation Manual instructions). The LIFT DOOR Instrument Panel Gauge Cluster indicator is turned ON and will remain ON as long as the wheelchair lift door is opened.

Wheelchair Lift Interlocks—Retracting and Stowing

The vehicle cannot be moved (the transmission cannot be released from Park (P) position, or the parking brake cannot be released), until the following procedures are completed. Also, refer to the **Transmission** and **Parking Brake** sections for their wheelchair interlocks.

Follow the steps below in the order listed when retracting and stowing the wheelchair lift:

1. First stow the wheelchair lift (according to the manufacturer's Operation Manual instructions).
2. Then close the wheelchair lift door (according to the manufacturer's Operation Manual instructions). The LIFT DOOR Instrument Panel Gauge Cluster indicator will then turn OFF.

Wheelchair Lift Alarm

The Instrument Panel Gauge Cluster alarm (a continuous beeping) will be triggered if:

1. The wheelchair lift door is extended AND:
2. a. The parking brake is not applied (knob is not pulled and released or manual parking brake pedal is not depressed) OR
b. The transmission is not in Neutral (N) or Park (P).

NOTE: The alarm will continue to beep until the above conditions are corrected.

Emergency Exits

Opening any emergency exit will trigger an alarm to alert the driver when the key is in the on or accessory position.

NOTE: A label stating Do Not Block is required by NHTSA no later than April 21,2004. Either above or below each emergency door and side emergency exit window. This label is a warning to the user of the bus not to block the emergency exits with wheelchair, child restraint systems or other items; for example, trash containers.

Pull up the RED lever to unlatch the emergency door. After the door is unlatched, push outward to open. Ensure the printed operating instructions are present and visible at all times. Inspect every emergency exit every day for proper operation.

Emergency Door

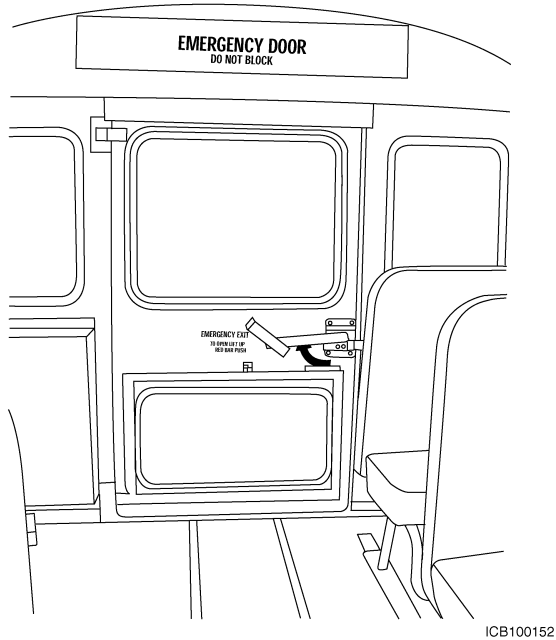

Emergency Exit Windows

Two styles of optional emergency exit windows are available for this bus, either horizontal or vertical.

Horizontal Emergency Exit Window

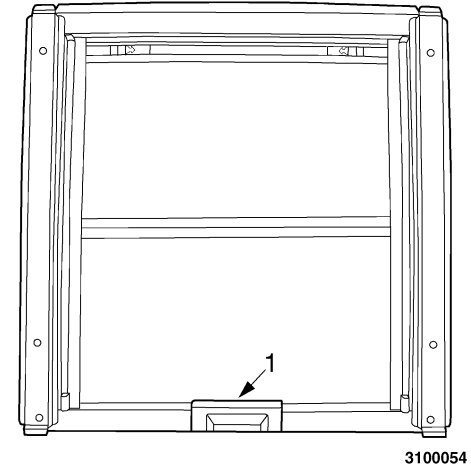

1. Release Handle

Pull up on the release handle to unlatch the Horizontal Emergency Exit Window. After the window is unlatched, push outward on the bottom of the top hinged window to open.

Passenger Control

Vertical Emergency Exit Window

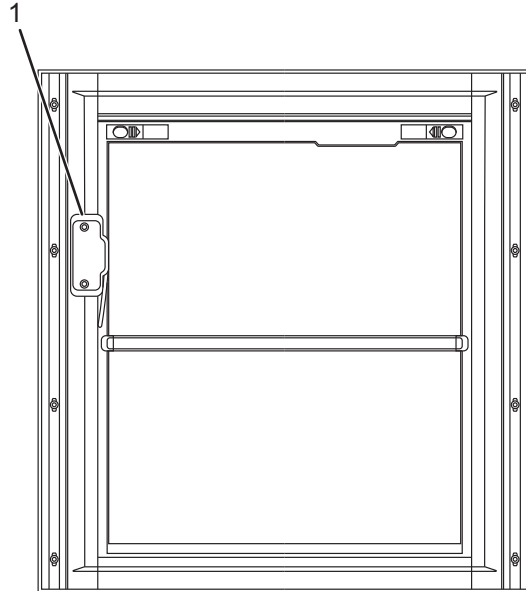

0000428403

1. Release Handle

NOTE: Ensure the printed operating instructions are present and visible at all times. Inspect every emergency exit every day for proper operation.

Pull up on the release handle to unlatch the Vertical Emergency Exit Window, and push the window outward to open.

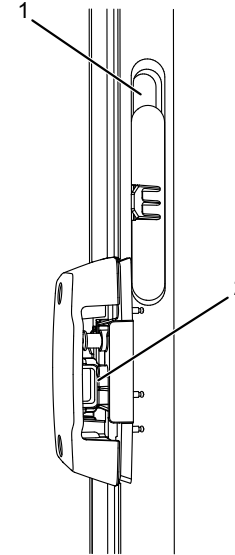

0000433122

1. Slide lubrication point
2. Release handle lubrication point

Make sure windows are free of dirt, fog, condensation, and snow. Make sure the windows can open and close completely. Once a year, pull up on the release handle to open the emergency windows and lubricate the window slides (2) and release handle. Only specific lubricants should be used on the emergency exit window lubrication points. For emergency exit window lubrication specification, refer to the **Maintenance Intervals and Specifications** section of this manual.

Roof Vent / Hatch

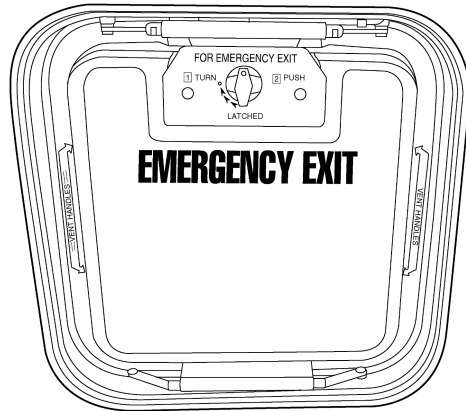

ICB100151

When using the vent, push upward at the locations marked on the hatch.

Open the hatch by turning the RED knob to the 2 position, then push upward on the knob. Ensure the printed operating instructions are present and visible at all times. Inspect every emergency exit for proper operation every day. The emergency hatch type may be different in your bus. If your emergency hatch is different, become completely familiar with its operation before driving the bus.

Vandal Locks

The optional vandal lock mechanism is used to lock access doors, rear emergency window, and roof hatches to prevent unauthorized access to the bus while not in use. Vandal locks can be provided on front entrance doors, side emergency door, rear emergency window, roof hatches, and lift doors.

On the side emergency door, the vandal lock is a dead bolt lock that the driver slides in place to secure the bus from unwanted vehicle access.

On the rear emergency window, the driver uses the vandal lock handle to slide the lock in place.

The vandal lock, for the front entrance door, is engaged with a standard-looking door key, which is rotated clockwise to lock the door and counterclockwise to unlock the door.

Vandal locks for all emergency exits include ignition starter interlocks. The front entrance door vandal lock may include an ignition starter interlock.

Vandal Locks with Starter Interlock (If Equipped)

NOTE: Once the bus engine is running, the vandal lock / starter interlock will not stop the bus, but it will prevent it from restarting when the lock is engaged. The alarm will be activated to alert the driver.

As an extra measure of security, the bus may be equipped with the optional vandal lock feature with starter interlock.

Passenger Control

The ignition starter interlock prevents the bus from being started while the exit door is locked. If the ignition switch is turned to the START position while vandal locks are in place, an alarm will be activated as long as the door is locked.

Entrance Door Lock (If Equipped)

As an extra measure of security, the bus may be equipped with an entrance door lock. This lock mechanism is used to lock the entrance door to the bus in order to prevent unauthorized access to the bus while not in use or attended.

To lock the entrance door lock feature, rotate the latch clockwise. To unlock, rotate the latch counterclockwise.

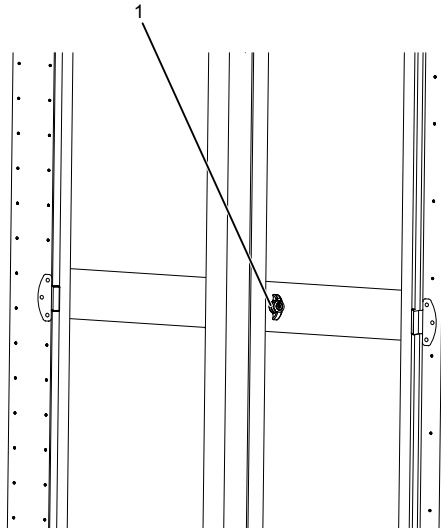

0000431525

1. Latch

SECTION 7 — SEATING AND SAFETY RESTRAINTS

Driver Seat Adjustment



WARNING

To prevent personal injury and / or death, or damage to property, always use occupant restraint system when vehicle is moving. Any location in the vehicle not equipped with a seat belt, bunk restraint belts, or sleeper berth restraint webbing should not be occupied when the vehicle is being operated.



WARNING

To prevent personal injury and / or death, or damage to property, do not adjust driver's seat while vehicle is moving. The seat could suddenly or unexpectedly move, causing the driver to lose control of vehicle.



WARNING

To prevent personal injury and / or death, or damage to property, use caution and reduce speed when operating this vehicle over rough roads or surfaces as this can cause loss of vehicle control. Properly adjusted seats and seating systems may not compensate completely for severe road conditions. Ensure that head clearance will be maintained during all road conditions, as the seat may move up and decrease the available space.



WARNING

To prevent personal injury and / or death, or damage to property, set the parking brake and place transmission in park (if available), or neutral prior to exiting the driver seat.

NOTE: This bus may be equipped with an optional driver seat that may be different than the one described in this manual. If so, refer to the seat manufacturer's manual for proper operation and maintenance.

Seating and Safety Restraints

Seat Height Adjustment

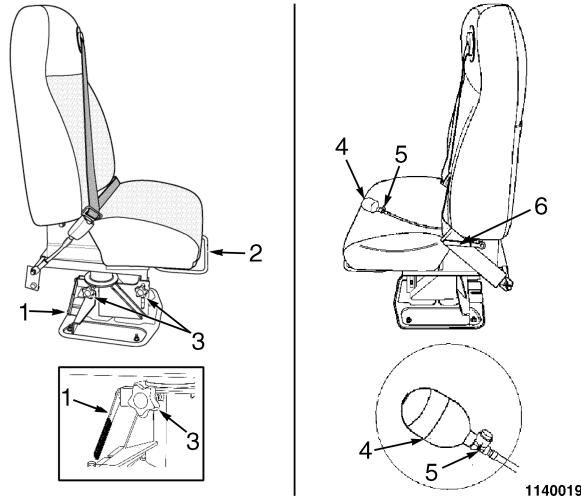

1. Seat height lever
2. Forward / Aft adjustment bar
3. Seat height adjustment lock knob
4. Lumbar support squeeze bulb
5. Release valve
6. Seatback adjustment lever

There are three possible seat heights available: top, middle, and low. At the top position three adjustment holes are visible, and at the low position none of the holes are visible.

WARNING

To prevent personal injury and / or death, or damage to property, do not adjust driver's seat while vehicle is moving. The seat could suddenly or unexpectedly move, causing the driver to lose control of vehicle.

NOTE: All seat height adjustments must be made WHILE NOT SITTING IN THE SEAT.

Adjust the seat height as follows:

1. Loosen the seat height adjustment lock knob just enough to allow seat height adjustment.
2. While standing to the side of the seat, lift and hold the seat height lever while raising or lowering the seat to the desired height, then release the lever. While adjusting the seat height, the seat height lever may remain in the up position. The location and orientation of the height adjustment lever may vary.
3. When at the desired position, move the seat slightly up or down until the seat height lever snaps to its height engaged (down) position.
4. After the desired seat position is satisfied, tighten the seat height adjustment lock knob.

Forward / Aft Adjustment

Lift and hold the forward / aft adjustment bar to move the seat forward or backward, and release the lever at the desired position.

Seatback Adjustment

The seatback adjustment lever is located on the left of the seat. Lift and hold the seatback lever while moving the seatback forward, or rearward, and release the lever at the desired position.

Lumbar Support Adjustment

Squeeze the lumbar support squeeze bulb to move the support upward. To move the lumbar support downward, release the air from the lumbar support squeeze bulb, by turning the release valve counterclockwise.

Optional Air Suspension Seat

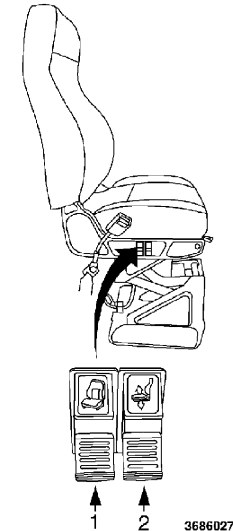

1. Lumbar adjustment
2. Height adjustment

Forward / Aft Adjustment Lever

Move and hold the forward / aft adjustment lever to the left to move the seat forward or backward.

Seating and Safety Restraints

Seatback Adjustment Knob

The seatback adjustment knob is located on the left of the seat at the intersection of the seatback and the lower seat cushion. Turn the seatback adjustment knob clockwise to tilt the seatback forward and rotate the knob counterclockwise to tilt the seatback rearward.

Lumbar Support

Pull the left switch (lumbar support switch) upward or push downward to adjust the lumbar support to your preference.

Height Adjustment Switch

Lift the height adjustment switch upward to adjust the seat height. While seated, pull the lever up and release when an acceptable height has been achieved. To lower the seat, depress the switch and stop when an acceptable height has been reached.

Driver Seat Belts



WARNING

To prevent personal injury and / or death, or damage to property, any seat belt in use during an accident must be replaced. When replacement of any part of the seat belt is required, the entire belt must be replaced, both retractor and buckle sides.



WARNING

To prevent personal injury and / or death, or damage to property, properly inspect and maintain seat belts.

Wear your seat belt at all times the vehicle is in motion to avoid personal injury. Before fastening the seat belt, adjust the seat to the desirable driving position. Driver's lap and shoulder (three-point) seat belt with retractor is standard.

Driver's Adjustable Lap and Shoulder (Three-Point) Belt



WARNING

To prevent personal injury and / or death, or damage to property, position the safety belt height adjusters so that the belt rests across the middle of your shoulder. Failure to adjust the safety belt properly could reduce the effectiveness of the seat belt.

Inspect the entire seat belt assembly for corrosion, wear, fraying or weak spots. Check the retractor, latch, and buckle for proper function, and all seat belt mounting bolts for tightness.

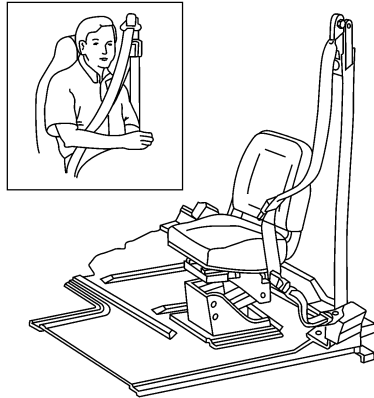

ICB100069

Bring the belt across your hips and chest and insert the latch plate into the buckle until secure to fasten the seat belt. The web is free to slide through the latch plate, allowing the belt tension to equalize across your hips and chest. The retractor is a locking type that allows the webbing to adjust for body movement.

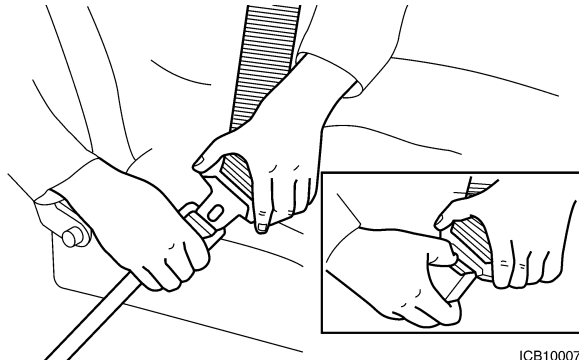

ICB100070

Press the release button to disconnect the seat belt.

Seat Belt Tether

NOTE: The majority of the driver seats have nonadjustable tethers. For Driver seats with adjustable tethers, follow the Tether Adjuster Procedure.

Tether Adjuster Procedure

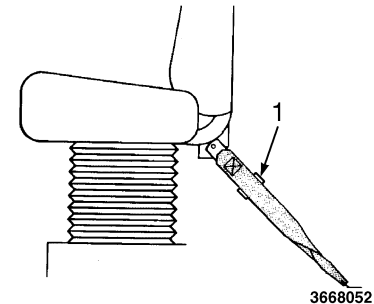

1. Tether adjuster

NOTE: The seat belt tether must be checked for proper adjustment prior to vehicle operation.

1. Adjust the driver seat fore and aft to accommodate driver comfort.
2. After the seat is adjusted, take weight off the seat to allow the seat to rise to its highest point.

Seating and Safety Restraints

3. Pull the webbing through the tether adjuster until there is no slack.

Adjusting the Length of the Tether

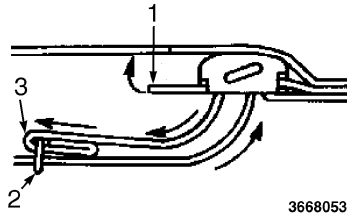

1. Tether adjuster
2. Wire loop
3. Nub

To shorten the tether, squeeze the tether adjuster and pull the nub and wire loop to move the webbing away from the tether adjuster (as shown by the arrows).

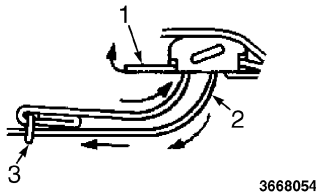

1. Tether adjuster
2. Strap
3. Wire loop

To lengthen the tether, squeeze the tether adjuster and, while firmly holding the strap, use the nub and wire loop to move the webbing toward the adjuster (as shown by the arrows).

Care of Seat Belts



To prevent personal injury and / or death, or damage to property, do not bleach or re-dye seat belt webbing. Bleaching or re-dyeing may cause a weakening / premature deterioration of the webbing.



To prevent personal injury and / or death, or damage to property, use caution when cleaning seat belts. Disinfectant products can contain solvent based chemicals that can adversely affect seat belt components.

NOTE:

- Do not use a 70% isopropyl solution as a wash solution.
- Do not use a 70% isopropyl solution wipe on seats that are hot from daytime heat.
- Vapors can accumulate quickly when using a 70% isopropyl solution wipe. Maintain adequate ventilation by opening windows and doors.
- The effectiveness of the 70% isopropyl solution can be diminished when used in high heat conditions due to evaporation.

Clean the belts occasionally with mild soap. Do not use cleaning solvents or abrasives.

A 70% solution of isopropyl alcohol can be used as a disinfectant wipe. A 70% isopropyl solution is readily available from local sources.

Inspection of Seat Belts

Inspect the buckle and latch plate for positive engagement and effective release. Inspect the webbing for damage or wear. Replace the entire belt if any deficiencies are found.

Seat Belt Cutter

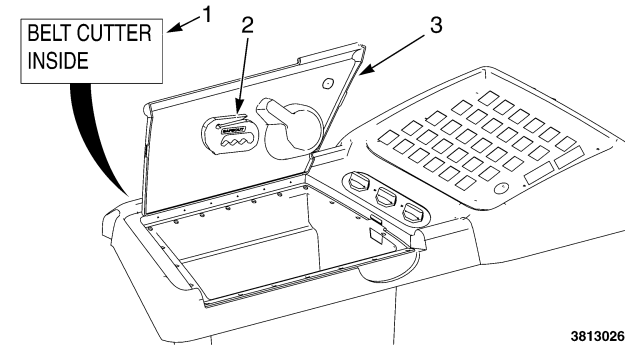

1. Belt cutter label
2. Seat belt cutter
3. Lid

If it becomes necessary to cut through a seat belt, the seat belt cutter is located inside of the driver's compartment lid.

NOTE: Location of seat belt cutter may vary according to state regulations.

Seating and Safety Restraints

Passenger Seat Belts

Buses may be equipped with optional passenger seat belts.



WARNING

To prevent personal injury and / or death, or damage to property, properly inspect and maintain seat belts.



WARNING

To prevent personal injury and / or death, or damage to property, any seat belt in use during an accident must be replaced. When replacement of any part of the seat belt is required, the entire belt must be replaced, both retractor and buckle sides.



WARNING

To prevent personal injury and / or death, or damage to property, pay strict attention to the following:

- Use all seating positions only with occupants who meet the following requirements: 4 years old or older, over 40 pounds, and 40 inches or taller.
- The shoulder height adjuster must be at or above the shoulder of the occupant.
- The hip of the occupant of the isle seat must not extend beyond the edge of the seat cushion.
- Backpacks must be removed before using the lap-shoulder restraint.
- Lap-shoulder belts should be tightened snugly around occupant.

Passenger Two-Point Seat Belt (Lap Belts)

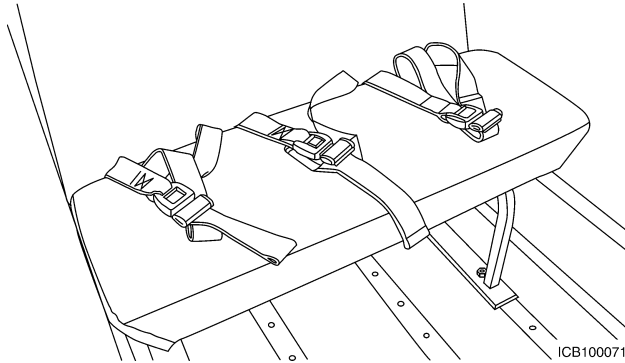

To loosen the belt, slide the latch up the webbing as far as necessary to make the belt go around the passenger's lap. Insert the latch plate into the buckle until secure. To loosen, pull up on the lap belt. Tighten the belt until it is snug by pulling on the loose end of the belt. Push the release button on the buckle to release the seat belt. Position the lap portion of the belt so that the webbing is below the passenger's waist, not over the stomach or abdomen area. The lap portion of the belt must be low and snug over the bony structure of the passenger's hips.

Passenger Three-Point Seat Belts (Optional)

Buckling Up

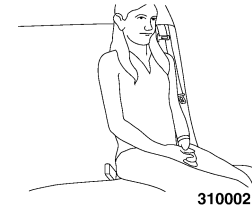

1. The passenger should sit as flat against the seat back as possible to achieve the best possible fit of the lap-shoulder belt on the passenger's upper and lower torso.

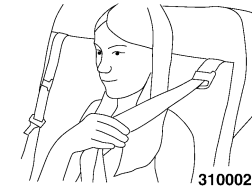

2. Pull out the shoulder belt webbing from the upper seat back. Do not let the belt get twisted. (The shoulder belt may lock if pulled across the body too quickly. If this happens, let the belt retract slightly to unlock it. Then pull the belt across you more slowly).

Seating and Safety Restraints

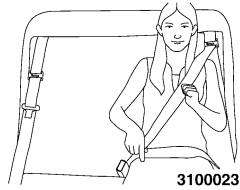

- Place the lap-shoulder belt over the shoulder and around the passenger's upper body.

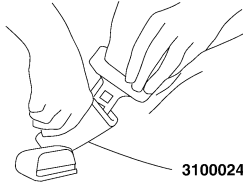

- Insert the latch plate into the matching seat belt buckle on the lower seat cushion.

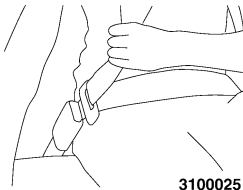

- Listen for an audible click when the latch plate is fastened. Check that the buckle connection is secure by pulling on the shoulder portion of the lap-shoulder belt.

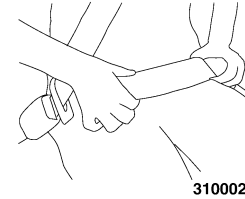

- Position the lap portion of the belt so that the webbing is below the passenger's waist, not over the stomach or abdomen area. The lap portion of the belt must be low and snug over the bony structure of the passenger's hips.

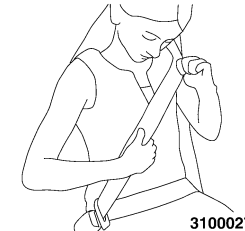

- Pull up on the shoulder portion of the lap-shoulder belt to tighten the lap portion.

THIS STEP IS IMPORTANT AND MUST BE DONE TO ENSURE PROPER FIT OF LAP-SHOULDER BELT TO PASSENGER

The shoulder portion of the belt must be snug across the chest and in the center of the passenger's shoulder.

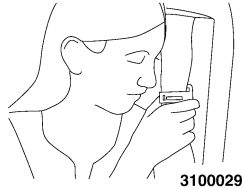

8. Position the shoulder height adjuster at or just above the passenger's shoulder. The shoulder belt should not cross the passenger's face or neck.

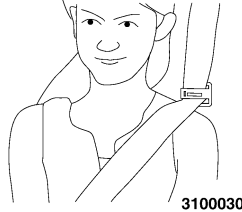

9. Ensure the lap-shoulder belt is snug and lies flat against the passenger. There should be no twisting of the webbing.

Unbuckling

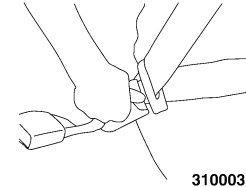

1. Push the RED buckle release button and remove the latch plate from the buckle. The buckle has a release mechanism that separates the latch plate from the buckle.
2. Allow the shoulder belt to retract and stow in the upper seat back.

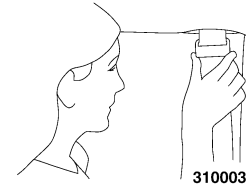

3. As a courtesy to the next passenger, move the shoulder height adjuster up to the highest position.

Seating and Safety Restraints

39-Inch Flex Seat



WARNING

To prevent personal injury and / or death, or damage to property, pay strict attention to the following:

- Use all seating positions only with occupants who meet the following requirements: 4 years old or older, over 40 pounds, and 40 inches or taller.
- The shoulder height adjuster must be at or above the shoulder of the occupant.
- The hip of the occupant of the isle seat must not extend beyond the edge of the seat cushion.
- Backpacks must be removed before using the lap-shoulder restraint.
- Lap-shoulder belts should be tightened snugly around occupant.

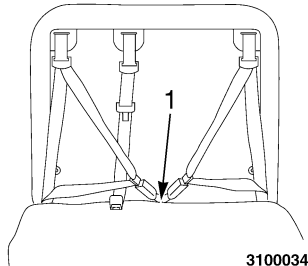

1. Sliding Dual Buckles (Two Seating Position)

Use for two children: Slide the sliding dual buckles on right side all the way left to create two seating positions.

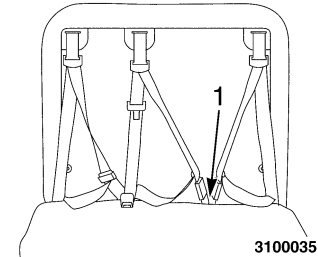

1. Sliding Dual Buckles (Three Seating Position)

Use for three children: Slide the sliding dual buckles on right side all the way right to create three seating positions.

Integrated Child Restraint Seats (Optional)



WARNING

To prevent personal injury and / or death, or damage to property, observe the following:

- Follow all instructions on the child restraint and in this manual.
- It is important to use an approved rearward facing infant restraint for a full year to allow the neck and spine to develop enough to support the weight of the child's head in the event of a collision.
- Adjust the belts provided with this child restraint snugly around your child.

 **WARNING**

To prevent personal injury and / or death, or damage to property, observe the following:

- A frayed or torn child restraint belt could rip apart in a collision and leave your child with no protection. Inspect the belt system periodically, checking for cuts, frays, or loose parts. Damaged parts must be replaced immediately.
- Do not disassemble or modify the system.
- Child restraint belt systems must be replaced after a collision if they have been damaged (such as a bent buckle or 5-point connector, or torn webbing). Similarly, the child restraint-equipped bench or bucket seat must be replaced after a collision if it is damaged (such as a bent or broken seat frame).
- For seats equipped with Smartframe Plus, check periodically for conditions indicated by the label.

Indiana Mills and Manufacturing Inc. (IMMI®) Integrated Child Restraint Seats (Optional)

 **WARNING**

To prevent personal injury and / or death, or damage to property, observe the following:

- Used only with children who weigh between 22 and 85 lb (10 and 39 kg), and whose height is 49 in (124 cm) or less, and who are under one year of age.
- Top portion of the seat cushion must be folded under lower portion of seat cushion to form seating surface for child.

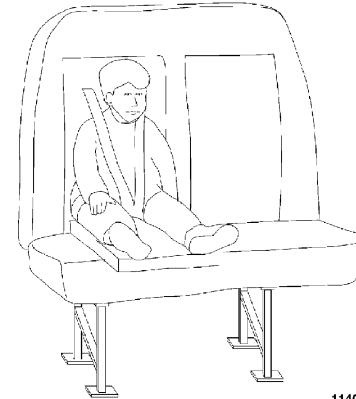

1140018

Seating and Safety Restraints

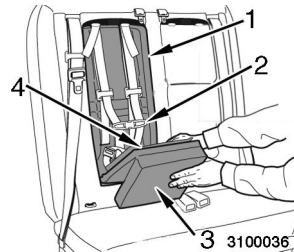

1. Removable seat pad
2. Chest clip
3. Two-piece seat cushion
4. Harness buckle

Activate the restraint system by lowering the two-piece seat cushion. Fold the top portion of the cushion under the bottom portion to form a seating surface for the child. Be sure seat belt buckles (if equipped) are NOT beneath the two-piece seat cushion. Failure to fold the seat cushion under can result in damage to the restraint and thus improper restraint of the child.

Open chest clip by squeezing middle tabs and pulling chest clip apart.

Unbuckle harness buckle by pressing down on RED release button.

To loosen harness, lift metal at top of seat and pull down on shoulder strap to loosen strap. Repeat with second shoulder strap.

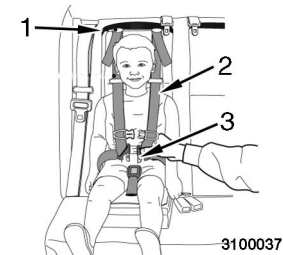

1. Metal tabs
2. Shoulder strap
3. Harness buckle

Place the child in the restraint with the child's back flat against the back of the bus seat cushion. Position shoulder straps over the child's shoulders.

Buckle harness by inserting buckle tongues into harness buckle.

Listen for an audible click when each buckle tongue is fastened.

Check that the buckle connection is secure by pulling on the shoulder straps.



1. Top strap

To tighten harness, pull down equally on top straps on both sides until the harness is snug around the child.

A snug strap should not allow any slack. It lies in a relatively straight line without sagging. It does not press on the child's flesh or push the child's body into an unnatural position.

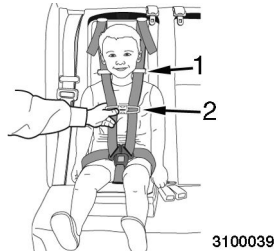

1. Shoulder height adjuster
2. Chest clip

Fasten chest clip by pushing both sides together, then position chest clip at middle of the child's chest, at armpit level.

Position each shoulder height adjuster at or just above the child's shoulder. Be sure harness is snug and tight on child's thighs and chest.

CE White Integrated Child Restraint Seats (Optional)



To prevent personal injury and / or death, or damage to property, observe the following:

This integrated child seat is designed for use only by children who weigh between 20 and 85 lb (9 and 39 kg).

Refer to the following illustration to become familiar with the parts of the child seat and five-point seat belts. This child restraint system conforms to U.S. Federal Motor Vehicle Safety Standard 213 and Canada Motor Vehicle Safety Standard No. 213.4

Seating and Safety Restraints

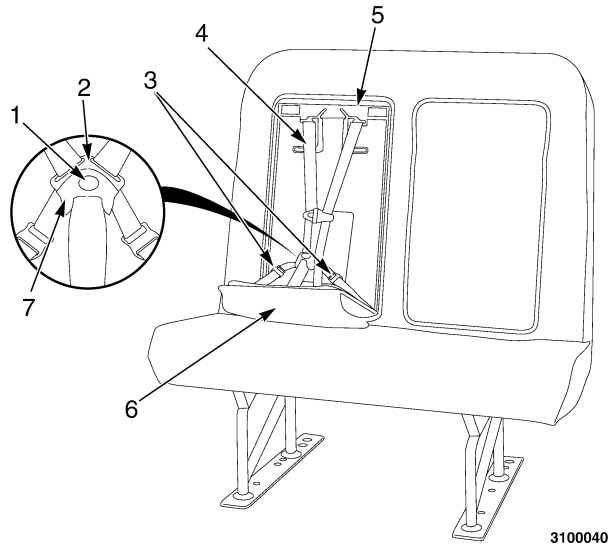

3100040

1. Buckle release button
2. Seat belt latch plate
3. Adjustment
4. Shoulder belt strap
5. Removable pad
6. Folded down leg rest pad
7. Buckle

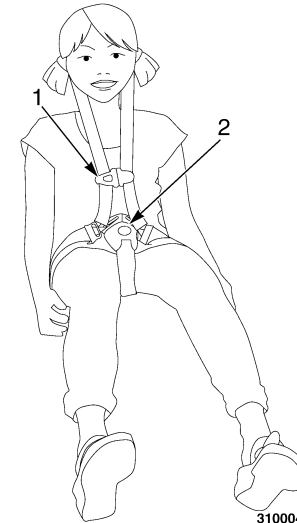

3100041

1. Shoulder belt clip
2. Seat belt latch plate

To open the child restraint, grasp the upper portion (leg rest pad) and lower the child seat cushion.

To secure the child:

1. Before placing the child in the seat, add slack to the shoulder belts. Release the seat belts by pulling up on the belt adjustment strap, then pull up on the seat belts.
2. Place the child into the child seat, pull the shoulder belts through the appropriate shoulder slot for the height of the child and put a shoulder belt over each shoulder.

Insert both seat belts latch plates into the buckle and pull up on them to ensure they are firmly latched.

NOTE: Be sure that the seat belt buckle is free of foreign objects that may prevent you from properly latching latch plates. If an object is in the opening, and cannot be removed, see your dealer for service immediately.

3. Fasten the two halves of the shoulder belt clip together and put it 2 - 3 in (5 - 7.6 cm) below the child's chin. The purpose of the clip is to keep the shoulder belts positioned correctly on the shoulders.

To remove the child, reverse Steps 1 through 3.

Child Restraint Anchorage Systems (Optional)

The following provides information pertaining to attaching add-on child seats to passenger seats with child restraint anchorage systems including tether anchors.

When installing an add-on child seat, follow the instructions located on the add-on child seat for the forward facing position. Ensure that the seat chosen is able to be installed in the forward facing position and is designed to be used with the child restraint anchorage system.

Passenger seats with optional child restraint anchorage systems for attaching add-on child seats are usually located in the first few rows of passenger seats behind the operator and / or entrance door. To determine the location of the passenger seats in the vehicle that are equipped with child restraint anchorage systems,

look for the pockets in the seat back just above the seat cushion with a bar inside, or bars protruding up, between the seat back and the seat cushion. Latch anchor locations may be identified with the anchorage symbol just above the anchor.

Canadian school buses and all commercial buses must attach the tether of the add-on child seat to the tether anchor located on the passenger seat per the following instructions. To locate the tether anchor (see **Location of the Tether Anchor**).

NOTE: Tethers are not required in U.S. school buses in combination with child restraint anchorage system (UCRA) when installing add on child restraint seats.

Passenger seats may have one or two child restraint anchorage systems. If two anchor systems are present in the same passenger seat, and only one add-on child seat is going to be installed, it is recommended to use the system closest to the wall to improve the mobility of the passenger in the open seat in case of an emergency.



WARNING

To prevent personal injury and / or death, or damage to property, observe the following:

Follow all instructions on the child restraint and in this manual, including the manufacturer's warnings for proper use of the child restraint system and latch attachments.

Seating and Safety Restraints

Location and Use of Lower Latch Anchors



WARNING

To prevent personal injury and / or death, or damage to property, refer to child restraint seat instructions for proper installation using the lower Latch Anchors and Tether Anchor.

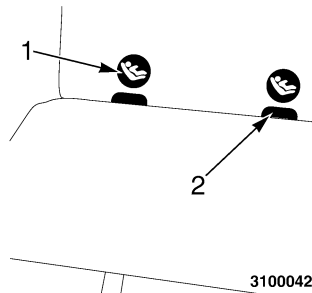

1. Anchorage symbols
2. Lower Latch anchors

Location of the Tether Anchor (Optional)

The tether anchor style and location may vary between seat manufacturers.

IC and CE White seats tether installation is as follows:

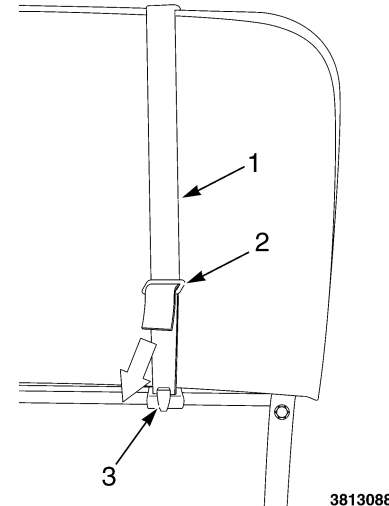

1. Child strap
2. Adjuster
3. Tether anchor

NOTE: IC and CE White tether anchors are mounted to the seat belt bar and are visible under the rear of the seat back.

For the attachment of an add-on child seat tether, wrap the tether over the seat as shown then connect the snap hook to the tether anchor. Adjust the tether to a snug and tight fit by pulling on the free end of the strap at the adjuster.

IMMI® Seats Tether Installation



1. Child seat tether

All base, three-point, and integrated child restraint (BTI) bus seats equipped with Latch are also equipped with tether anchors for add-on child seats.

Location and Use of Tether Anchors (BTI Bus Seats)

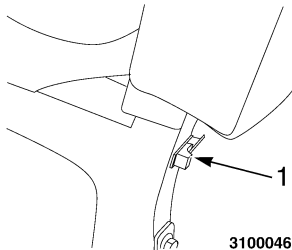

1. Tether anchor

Tether anchors are located on the aisle side rear pedestal and on the seat wall mount bracket rear edge.

Installing Tether

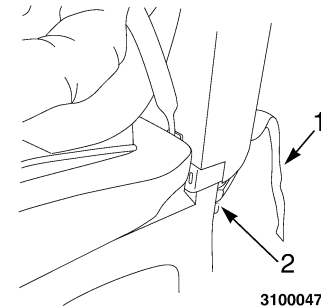

1. Strap (free end)
2. Tether anchor

To attach an add-on child seat tether, route the tether on the child seat over the top of the belted BTI bus seat. Extend the tether and connect the snap hook to the nearest tether anchor provision at the lower rear of the seat. Adjust the tether to a snug and tight fit by pulling on the free end of the strap at the adjuster.

Location and Use of Tether Anchors (SafeGuard® XChange Bus Seats)

SafeGuard® XChange bus seats are equipped with tether anchors for add-on child seats.

Seating and Safety Restraints

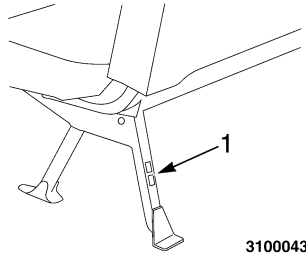

1. Tether anchor

Tether anchors are located on the aisle side rear pedestal and on the seat wall mount bracket rear edge.

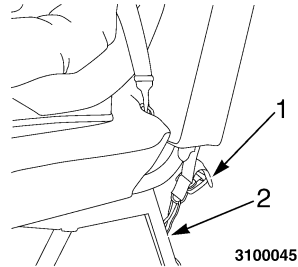

1. Strap (free end)
2. Tether anchor

To attach an add-on child seat tether, route the tether on the child seat over the top of the SafeGuard® XChange bus seat. Extend the tether and connect the snap hook to the nearest

tether anchor provision at the lower rear of the seat. Adjust the tether to a snug and tight fit by pulling on the free end of the strap at the adjuster.

Cushion Release Latch



WARNING

To prevent personal injury and / or death, or damage to property, ensure seat belts and equipment are held out of the way when lowering the cushion to seated position. Keep hands and feet clear while lowering the seat cushion.

Rear Latching

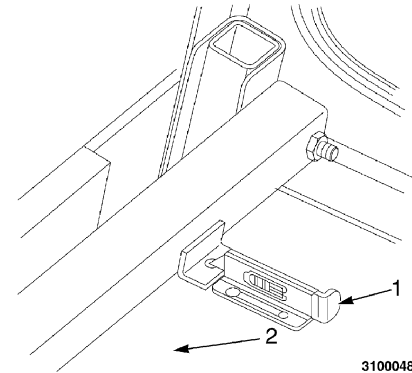

1. Latch
2. Seat bottom

Optional release latches may vary based on seat style. Seats automatically latch when sat upon. Pull up on seat cushion to confirm cushion is latched.

For both rear and side latching designs, pull the latch to release.

Side Latching

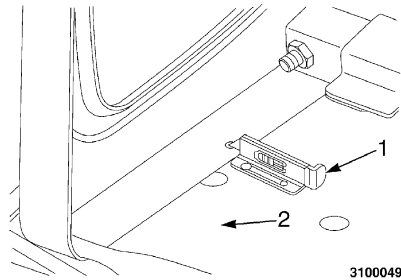

1. Latch
2. Seat bottom

Track Seat Mounting Seat Type Specific

The following diagrams outline the maximum seat spacing for specific seat and barrier types to ensure FMVSS / CMVSS 222 compliance School bus required. Original seat layout for a specific unit can be obtained by contacting your IC Bus® dealer.

NOTICE

COMPLIANCE WITH FMVSS-222 PASSENGER CRASH PROTECTION

1. ALL SEATS MUST FACE FORWARD
2. EACH SEAT MUST BE PLACED BEHIND ANOTHER SEAT OR BARRIER OF MATCHING WIDTH.
3. FOR PROPER SEAT SPACING MEETING FMVSS & CMVSS REQUIREMENTS, SEE OWNERS MANUAL.

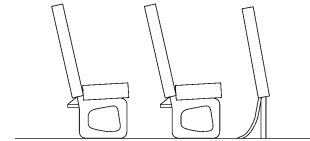

g3100050

The standard track seat label is found on the front bulkhead of all buses with track seating.

Seating and Safety Restraints

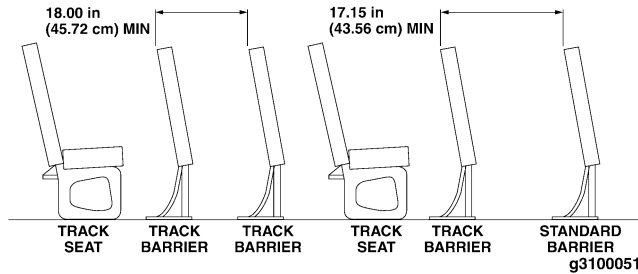

Minimum spacing with standard barrier to track barrier, and track barrier to track barrier.

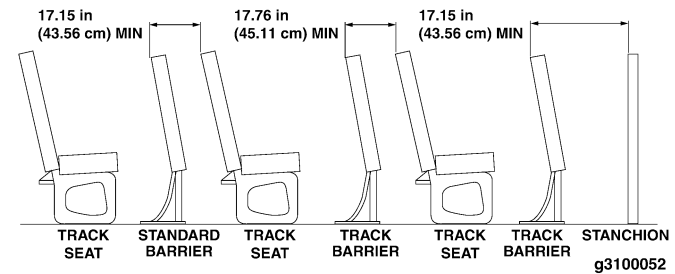

Minimum spacing with stanchion to track barrier, track seat to track barrier and track seat to standard barrier.

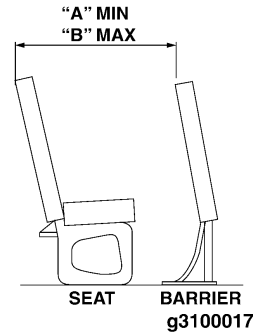

Barrier Type	Seat	A - Minimum	B - Maximum
Standard	IC Track	28.75 in (73.03 cm)	34.35 in (87.25 cm)
Track	IC Track	29.24 in (74.27cm)	34.24 in (86.97 cm)
Standard	CEW-CR11 Track Seat (with or without lap belts, with Integrated Child Seat)	28.51 in (72.41 cm)	32.54 in (82.65 cm)
Track	CEW-CR11 Track Seat (with or without lap belts, with Integrated Child Seat)	29.10 in (73.91 cm)	32.10 in (81.53 cm)

Barrier Type	Seat	A - Minimum	B - Maximum
Standard	CEW-QSCR11 Track Seat (with 3-point belts, with Integrated Child Seat)	28.49 in (72.36 cm)	32.52 in (82.60 cm)
Track	CEW-QSCR11 Track Seat (with 3-point belts, with Integrated Child Seat)	29.35 in (74.55 cm)	32.35 in (82.17 cm)
Standard	CEW-QS11 Track Seat (with 3-point belts, without Integrated Child Seat)	28.53 in (72.47 cm)	32.56 in (82.70 cm)
Track	CEW-QS11 Track Seat (with 3-point belts, without Integrated Child Seat)	29.36 in (74.57 cm)	32.36 in (82.19 cm)
Standard	IMMI® Track Seat (without Integrated Child Seat)	30.54 in (77.57 cm)	36.44 in (92.56 cm)
Track	IMMI® Track Seat (without Integrated Child Seat)	30.92 in (78.54 cm)	34.92 in (88.70 cm)
Standard	IMMI® ICS Track Seat (with Integrated Child Seat)	30.54 in (77.57 cm)	36.44 in (92.56 cm)
Track	IMMI® ICS Track Seat (with Integrated Child Seat)	30.92 in (78.54 cm)	35.92 in (91.24 cm)

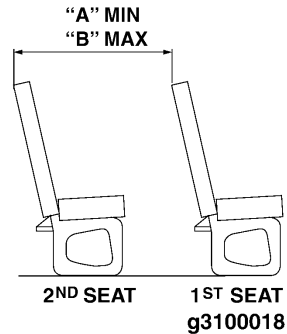

Seat to Seat			Spacing	
First Seat	Second Seat	A - Minimum	B - Maximum	
IC Track	IC Track	26.00 in (66.04 cm)	31.00 in (78.74 cm)	
IC Track	CEW-CR11 Track Seat (with or without lap belts, with Integrated Child Seat)	25.87 in (65.71 cm)	28.87 in (73.32 cm)	

Seating and Safety Restraints

Seat to Seat			Spacing	
First Seat	Second Seat	A - Minimum	B - Maximum	
IC Track	IMMI® ICS Track Seat (with Integrated Child Seat)	27.68 in (70.31 cm)	32.68 in (83.01 cm)	
CEW-CR11 Track Seat (with or without lap belts, with Integrated Child Seat)	IC Track	29.13 in (73.99 cm)	34.13 in (86.69 cm)	
IMMI® ICS Track Seat (with Integrated Child Seat)	IC Track	30.54 in (77.57 cm)	36.44 in (92.56 cm)	
CEW-CR11 Track Seat (with or without lap belts, with Integrated Child Seat)	CEW-CR11 Track Seat (with or without lap belts, with Integrated Child Seat)	28.00 in (71.12 cm)	31.00 in (78.74 cm)	
CEW-QSCR11 Track Seat (with 3 point belts, with Integrated Child Seat)	CEW-QSCR11 Track Seat (with 3-point belts, with Integrated Child Seat)	28.00 in (71.12 cm)	31.00 in (78.74 cm)	
CEW-QS11 Track Seat (with 3-point belts, without Integrated Child Seat)	CEW-QS11 Track Seat (with 3-point belts, without Integrated Child Seat)	27.00 in (68.58 cm)	30.00 in (76.20 cm)	
CEW-QSCR11 Track Seat (with 3-point belts, with Integrated Child Seat)	CEW-QS11 Track Seat (with 3-point belts, without Integrated Child Seat)	27.00 in (68.58 cm)	30.00 in (76.20 cm)	
CEW-QS11 Track Seat (with 3-point belts, without Integrated Child Seat)	CEW-QSCR11 Track Seat (with 3-point belts, with Integrated Child Seat)	28.00 in (71.12 cm)	31.00 in (78.74 cm)	
IMMI® Track Seat (without Integrated Child Seat)	IMMI® Track Seat (without Integrated Child Seat)	27.00 in (68.58 cm)	31.00 in (78.74 cm)	
IMMI® ICS Track Seat (with Integrated Child Seat)	IMMI® ICS Track Seat (with Integrated Child Seat)	27.00 in (68.58 cm)	32.00 in (81.28 cm)	
IMMI® Track Seat (without Integrated Child Seat)	IMMI® ICS Track Seat (with Integrated Child Seat)	27.00 in (68.58 cm)	32.00 in (81.28 cm)	
IMMI® ICS Track Seat (with Integrated Child Seat)	IMMI® Track Seat (without Integrated Child Seat)	27.00 in (68.58 cm)	31.00 in (78.74 cm)	

SECTION 8 — CLIMATE CONTROLS

Heater System



WARNING

To prevent personal injury and / or death, or damage to property, observe the following:

Never drive the vehicle unless the windshield and all other windows are clear. A fogged, ice / snow covered, or dirty windshield or window limits vision. To improve defroster efficiency, remove ice and / or snow by hand from the windshield and windows with a non-metallic scraper.

Driver Heater

The driver heater console is located below the left switch panel.

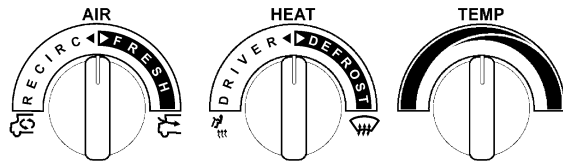

3813094

Adjust the air knob to provide outside air into the driver area.

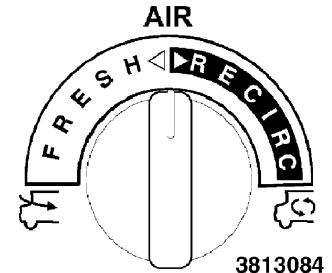

3813084

Adjust the heat knob to direct the air flow either into the driver area or the defrost area.

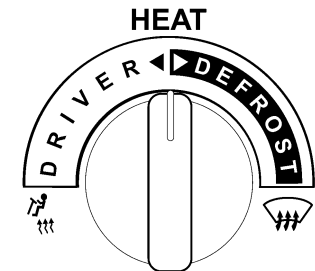

3813095

Three heater control knobs provide air flow direction, fresh air or recirculation control, and temperature selection.

Climate Controls

Adjust the temperature knob to control the temperature of the air through the heater vents.

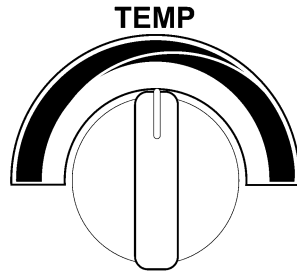

ICB100503

The heater fan speed is controlled by the driver heater defrost fan switch on the left console switch panel.

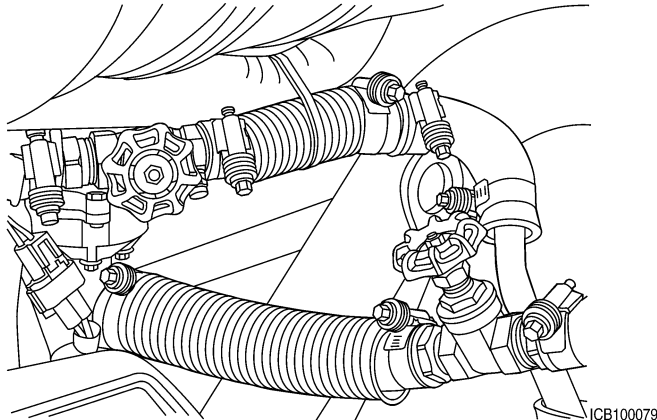

ICB100079

Auxiliary Heaters

The Midship / Rear heater switches provide blower speed control for the passenger compartment heaters and are located on the left switch panel. The control switch is labeled OFF / LO / HI.

Defrost Operating Instructions

The defroster blower is controlled by the three-position (OFF / LOW / HIGH) DRIVER HEATER / DEFROST fan switch, located on the left switch panel. Press the switch to the desired position to control blower speed.

Air is directed through the defrost duct to the windshield and side window outlets utilizing the defrost climate control heat selector. Use this mode at maximum fan speed and temperature setting for best windshield and side window defrosting.

If equipped, the optional step well heater may be turned ON for added air flow to the defroster vents.

Auxiliary Fuel-Fired Heater System (Optional)

Introduction

The auxiliary heater system is designed to provide additional heating capacity in cold weather conditions.

The auxiliary heater system is connected directly into the fuel and power supply of the bus: therefore, external hook-ups are not needed and the auxiliary heater system can be operated no matter where the bus is located.

Description

The auxiliary heater system consists of a fuel fired coolant heater, coolant plumbing, and wiring. The coolant plumbing connects the coolant heater to the engine and body heating system. The coolant heater location will vary, but is typically mounted on the left frame rail near the front of the bus. A fuel line is connected to the fuel tank to supply the coolant heater. An exhaust tube is routed from the coolant heater out the left-side of the bus.

When turned ON, fuel is supplied to the coolant heater and is ignited by a glow pin that establishes a flame that heats the coolant. The heated coolant is circulated through the bus coolant system and the engine block.

NOTE: The coolant heater is also equipped with safety features such as a flame sensor, temperature sensor, and overheat sensor that constantly monitor the coolant heater and will shut down if any problems occur.

Operation



WARNING

To prevent personal injury and / or death, or damage to property, the auxiliary heater system must be OFF before filling any fuel tank or moving the vehicle into an enclosed area where combustible fumes may be present.



WARNING

To prevent personal injury and / or death, or damage to property, the auxiliary heater system must not be operated in garages or other enclosed areas without properly venting the heater unit exhaust to the outside.



WARNING

To prevent personal injury and / or death, or damage to property, the use of this auxiliary heater system requires that the engine coolant be of a proper mixture so as to prevent freezing or slushing. Refer to the engine manufacturer's manual for specific coolant mixture recommendations. Frozen or slushy coolant can cause a blockage leading to rapid pressure buildup in the system hoses.

Climate Controls

Heater Control Switch

Turn the booster pump switch to the ON position to enable the auxiliary heater system. The booster pump switch is located in the left console switch panel.

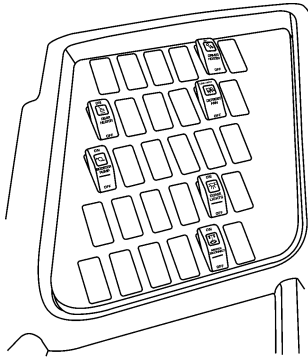

ICB100043

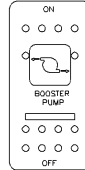

NOTE: On initial start-up, the heater may require several start attempts to self-prime the fuel system.

Heating Mode

NOTE: If the heater should shut down due to flame out while in running mode, it will automatically attempt one restart. If successful, it will continue to run. If not, it will shut down completely with a cool-down cycle.

NOTE: During operation, the heater continually senses the input voltage from the batteries. If the input voltage drops to approximately 12.1 volts or rises above 16 volts, the heater will automatically shut down with a cool-down cycle.

Depending on the heat requirements, the heater is automatically controlled in stages:

1. HIGH
2. LOW
3. OFF (controlled pause)

The temperature limits are permanently programmed in the electronic control unit.

NOTE: If the heater fails to start the first time, it will automatically attempt a second start. If unsuccessful, the heater will shut down completely.

Switching-Off Sequence

To turn the system OFF, set the booster pump switch to the OFF position. When the heater is switched OFF, manually or automatically, it starts a controlled cool-down cycle:

1. The fuel supply is shut off and the flame is extinguished.
2. The combustion air blower and coolant pump continue to run for 130 seconds to cool down.
3. The heater shuts OFF.

NOTE: An optional programmable seven day timer is available for the auxiliary fuel-fired heater system. Follow manufacturer's guide for operating instructions.

Air Conditioning

Your bus may have an aftermarket air conditioning system. Check the manufacturer's operation guide for operating instructions.

Integrated Air Conditioning System (IC Air)

This vehicle may be equipped with an optional skirt-or roof-mounted, factory-installed Integrated Air Conditioning (IC Air) system. Before operating the system, become familiar with the climate control system operating controls.

Becoming familiar with your IC Air climate control system operating controls will enable you to realize maximum system performance and maintain a comfortable environment for you and your passengers.

The system controls consists of two rotary switches, one controlling the evaporator fans and the other controlling the thermostat. The following illustration will identify both switches of the control system.

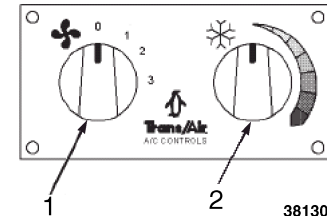

Item #	Name	Functional Description
1	System OFF / Fan Speed control: This control has four (4) positions: 0 thru 3	<ul style="list-style-type: none"> • The 0 position is the system OFF position. • Position 1 = Low evaporator fan speed. • Position 2 = Medium evaporator fan speed. • Position 3 = High evaporator fan speed.
2	Air Conditioned Temperature Control	Clockwise = Cooler Counter Clockwise = Warmer.

Circulation Fans



WARNING

To prevent personal injury and / or death, or damage to property, wait until the motor cools off before repositioning the circulation fan as the fan motor can become extremely hot when operated in normal ambient temperatures for long periods of time.

Some buses are equipped with circulation fans. The controls are labeled RIGHT FAN and LEFT FAN and are located on the left switch panel driver console. Each fan has OFF / LO / HI speed control.

Each fan can be positioned in several directions. First turn its fan control switch to the OFF position and then grasp the cage and pivot fan to the desired position to reposition the fan.

Heater Booster Pump

The optional heater booster pump assists coolant flow from the engine and increases heater performance. Turn the heater booster pump ON to provide the vehicle with additional interior heat.

NOTE: Do not use the heater booster pump unless the heater cutoff valve is manually opened.

Heater Cutoff Valve

NOTE: The illustration is for reference only and may differ from the actual vehicle.

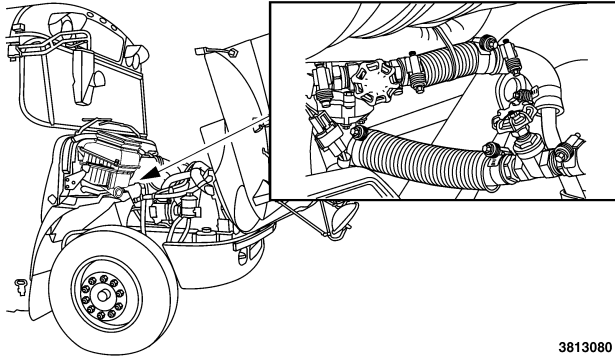

3813080

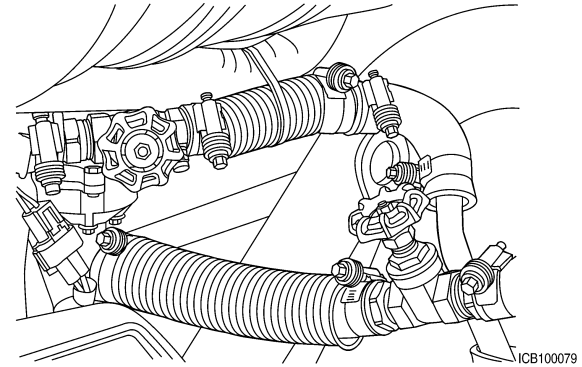

The heater cutoff valve for the coolant supply is under the hood.

Turn the heater cutoff valves ON (counterclockwise) whenever the heater is used.

Turn the heater cutoff valves OFF (clockwise) to stop hot coolant from being routed into the bus on hot days.

SECTION 9 — OPERATION

Starting Procedures

Starting the Engine



WARNING

To prevent personal injury and / or death, or damage to property, observe the following:

Do not operate a diesel engine near flammable vapors as this may cause the engine speed to increase uncontrollably and overspeed.

Turning OFF the ignition key /switch will not slow or stop the engine due to uncontrollable fueling of the engine through flammable vapors being drawn into the engine air inlet. Operation of components such as starter, alternator, electric motors, and static electricity could also ignite flammable vapors.

Do not operate the bus in the possible presence of flammable vapors unless both a complete hazard analysis is performed and necessary additional safety processes and / or equipment such as vapor testing, air intake shutoff devices and ventilation, are utilized. The operator is responsible for using those processes and / or equipment to ensure that the diesel engine and all other components on the bus can be operated safely under the specific conditions and hazards that may be encountered.



WARNING

To prevent personal injury and / or death, or damage to property, do not use volatile starting aids such as ether, propane, or gasoline in the engine air intake system. Glow plugs and / or grid heater will ignite vapors, which are an explosion hazard.



WARNING

To prevent personal injury and / or death, or damage to property, never add gasoline, gasohol, and / or alcohol to diesel fuel. This mixture creates an extreme fire and explosion hazard.



WARNING

To prevent personal injury and / or death, or damage to property, never start the engine unless you're sure the transmission selector is in Neutral and the brake is applied; otherwise, accidental movement of the vehicle can occur.



WARNING

To prevent personal injury and / or death, or damage to property, do not operate an engine beyond the maximum governed speed.

 **WARNING**

To prevent personal injury and / or death, or damage to property, never operate engines in enclosed areas without abundant forced ventilation (with garage doors and windows wide open), since exhaust gases from engines contain hazardous compounds. Maintain exhaust system in good operating condition.

 **WARNING**

To prevent personal injury and / or death, or damage to property, pay strict attention to the following:

Care should be taken to prevent sudden accelerations when both drive wheels are on a slippery surface. This could cause both drive wheels to spin and allow the vehicle to slide sideways, resulting in loss of vehicle control.

NOTE: Refer to the Engine Operation and Maintenance Manual supplied with your vehicle for special starting procedures.

Automatic Transmission Starter Interlock.

Automatic transmissions must be in neutral before the starter will engage.

NOTE: Refer to the Engine Operation and Maintenance Manual supplied with your vehicle for special starting procedures.

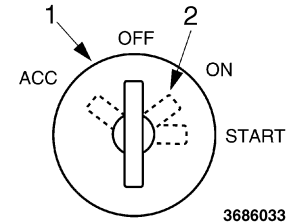

1. Key switch
2. Key position

NOTE: When the ignition switch is in the ON position, the brake system motor / pumps may be heard as they run briefly to maintain pressure in the system (see Brake section for a complete description).

1. Apply the parking brake. Place the transmission in the neutral position. Turn OFF the headlights and all accessories.
2. Turn the ignition switch clockwise to the ON position. If the WAIT TO START indicator comes on, which means the glow plugs are warming up, wait until the indicator goes out and then proceed.
3. Turn the key to the START position.
4. Do not press the accelerator when starting the engine.
5. When the engine starts, release the key.

If the engine does not start after 30 seconds of cranking, allow two to three minutes for the starter to cool before trying again. If the engine does not start after three attempts, determine the cause. Excessive cranking may damage the starter.

After the Engine Starts



WARNING

To prevent personal injury and / or death, or damage to property, if the CHECK ELEC SYS indicator illuminates and stays on, a major electrical system failure has occurred. Stop the vehicle and inspect critical accessories and gauges to determine driveability. Have vehicle repaired immediately.



WARNING

To prevent personal injury and / or death, or damage to property, if the CHECK ELEC SYS indicator illuminates and goes out after one minute, there is an active fault somewhere in the electrical system. Stop vehicle and inspect operation of exterior lamps to determine driveability.

NOTE: Refer to the Engine Operation and Maintenance Manual supplied with your vehicle for special starting procedures.

On some engines, the WAIT TO START indicator illuminates after the engine starts. Allow the engine to idle about three

minutes or until the engine coolant temperature gauge begins to rise. Maintain idle speed until the WAIT TO START indicator cycles off (approximately six minutes), which means the glow plugs have shut OFF.

- Do not increase engine speed until the oil pressure gauge indicates normal pressure.
- Ensure the engine oil pressure is indicated on the gauge within 20 seconds after starting.
- Idle the engine for three to five minutes before operating with a full load.
- Avoid extended idling (beyond 10 minutes) whenever possible. To maximize engine and Diesel Particulate Filter (DPF) life, see exhaust diesel particulate filter regeneration in this section for more information.
- When starting a cold engine, increase the engine speed (rpm) slowly to ensure adequate lubrication is available to the bearings.

Engine Features

The engines are electronically controlled diesel engines. The engine Electronic Control Module (ECM) monitors and controls the injection process and other engine functions. The ECM also communicates with the Body Controller (BC) and alerts it to out-of-range operating conditions. The BC, in turn, generates engine function indicators and warning indicators. Since many of the engine performance features are owner selectable and electronically programmable, some of the operating parameters will vary from vehicle to vehicle.

Operation

Certified Clean Idle

The engines have been designed to meet the new California Air Resources Board (CARB) idle reduction standards by generating less than 30-g/hr NOx emissions when idling. These engines can be identified by the Certified Clean Idle decal located on the left-side of the hood or driver's door.

HD-OBD Overview

The HD-OBD system uses many individual pre-programmed monitors to ensure the vehicle is meeting emissions standards. An HD-OBD monitor is a strategy to evaluate the performance of an emissions related system or component. All monitors are designed for execution in a prescribed frequency; some monitors run continuously, while some run a specific ratio against the number of drive cycles.

The operator will be alerted to emissions or other system problems when the Malfunction Indicator Lamp (MIL) illuminates. When the MIL illuminates, bring the vehicle in for service at the next available opportunity. The HD-OBD system does not change the way the vehicle should be driven, the recommended driving style, or the way you use the vehicle.

Self Diagnostics

All warning lamps are located on the Instrument Panel Gauge Cluster. When the ignition switch is turned ON, the warning lamps are illuminated and remain on while the ECM runs normal start-up tests, then goes OFF. If a warning lamp stays on or comes on while operating the vehicle, it is an indication that the vehicle needs service. When the warning lamp is illuminated, a Diagnostic Trouble Code (DTC) will be generated. Take the

vehicle to a service center as soon as possible as some optional features and / or engine power may be lost while the indicator is lit.

Fuel

Ultra-Low Sulfur Diesel Fuel Requirements

Ultra Low Sulfur Diesel (ULSD) fuel is required for all on-highway diesel engines used with advanced aftertreatment systems (Diesel Particulate Filters – DPF). For complete details on fuel requirements, see the **Engine Operation and Maintenance Manual** supplied with the vehicle.

Unacceptable Fuel Blends

Biodiesel blends having more than 5% pure biodiesel are not within ASTM D975 diesel specifications.

To determine acceptable biodiesel and biodiesel blends, refer to the **Engine Operation and Maintenance Manual** for the applicable engine.

Hazards of Diesel Fuel / Gasoline Blends



To prevent personal injury and / or death, or damage to property, never add gasoline, gasohol, and / or alcohol to diesel fuel. This mixture creates an extreme fire and explosion hazard.

Blending of gasoline and / or alcohol with diesel fuel is not recommended due to the hazards of fire / explosion and the detrimental effects on engine performance.

As little as 2% volume gasoline mixed with diesel fuel will create a flammable / explosive mixture in the fuel tank vapor space, which will pose an extreme fire / explosion hazard during refueling or engine operation.

Additional Unsafe Practices



WARNING

To prevent personal injury and / or death, or damage to property, never overfill the fuel tank. Overfilling the tank could cause fuel spillage and / or increased pressure inside the fuel tank. Pressure in an overfilled tank may cause leakage in the fuel system, which could result in a potential fire / explosive hazard.



CAUTION

To prevent vehicle and / or engine damage, do not mix propane with diesel fuel. Warranty claims will not be honored against engines that have used propane.



CAUTION

To prevent engine damage, do not mix engine oil with diesel fuel. Warranty claims will not be honored against engines that have used fuel mixed with oil.

Fuel and Lubricant Additives

IC Bus® vehicles are designed and built to operate satisfactorily on fuels and lubricants of good quality marketed by the petroleum industry. Use of any supplementary fuel or lubricant additives is not recommended. Malfunctions attributed to the use of such additives or failure to follow recommended fuel or lubricant recommendations may not be covered by any applicable warranty.

Fueling Procedures

NOTE: If your vehicle is equipped with dual fuel tanks, be sure to read and understand the following information before refueling the vehicle.

A dual tank system contains a primary and a secondary fuel tank.

With dual fuel tanks, the vehicle will be equipped with a fuel transfer pump system that will pump fuel from the secondary (reserve) fuel tank and send it to the primary (draw) fuel tank. The draw fuel tank must have fuel in it at all times, otherwise the vehicle may stall and may be difficult to restart (the fuel gauge reads the fuel level only from the draw fuel tank).

Operation

Therefore, when refueling, be sure that both tanks are filled completely, as it is sometimes difficult to determine which tank is the draw tank and which is the reserve tank.

Fueling Precautions

Federal Motor Carrier Safety Regulations require the driver or any employee of a motor carrier to observe the following requirements:

1. Do not fuel a motor vehicle with the engine running, except when it is necessary to run the engine to fuel the vehicle.
2. Do not smoke or expose any open flame in the vicinity of a vehicle being fueled.
3. Do not fuel a motor vehicle unless the nozzle of the fuel hose is continuously in contact with the intake pipe of the fuel tank.
4. Do not permit any other person to engage in such activities as would be likely to result in fire or explosion.

Reserve Fuel

No extra supply of fuel for the propulsion of the vehicle or for the operation of accessories shall be carried on any motor vehicle, except in a properly mounted fuel tank or tanks.

Restarting After Running Out of Fuel

It may be necessary to bleed the fuel system. Refer to **Bleeding Air From Fuel System** in the **Engine Operation And Maintenance Manual** supplied with your vehicle.

Engine Brake, Exhaust Brake, or Retarder (Optional)



To prevent personal injury and / or death, or damage to property, do not use the vehicle retarder, engine or exhaust brake on slippery road surfaces. Doing so may cause wheel slippage and / or loss of vehicle control.

NOTE: The engine or exhaust brake should never be considered a substitute for the vehicle service brakes. The service brakes should always be viewed as the primary vehicle slowing system. Service brakes are always used to bring vehicle to a complete stop.

Engine and Exhaust Brake Systems Operation

Vehicles with N9 and N10 engines utilize either the optional Diamond Logic® Engine Brake or the optional Diamond Logic® Exhaust Brake for additional braking in various operating conditions.

The optional **Diamond Logic® Engine Brake** is a compression style brake that utilizes the injection control system pressure and the closed vanes of the turbocharger for maximum braking power. The engine brake is controlled by the switch panel switches: ENGINE BRAKE ON / OFF, and ENGINE BRAKE SELECTOR 1 / 2 / 3. To activate the engine brake, place the ENGINE BRAKE ON / OFF to the ON position (the switch indicator will turn ON). The ENGINE BRAKE SELECTOR 1 / 2 / 3 switch is used to adjust the amount of braking applied.



NOTE: The ECM will not allow the Diamond Logic® Engine Brake to operate until the engine oil has reached the acceptable minimum temperature, therefore, do not attempt to activate the engine brake until the engine has reached full operating temperature.

The optional **Diamond Logic® Exhaust Brake** accomplishes the braking effects using the closed vanes of the turbocharger to increase exhaust back-pressure and restrict airflow. The exhaust brake is controlled by the ON / EXH BRAKE switch, located in the switch panel. To turn the exhaust brake ON, place the ON / EXH BRAKE switch to the ON position (the switch indicator will turn ON).

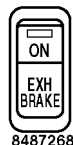

NOTE: Both the engine brake and exhaust brake features will automatically deactivate if either the accelerator or the clutch is pushed, or when the engine speed falls to 1,000 rpm.

Operational Modes

Coast Mode. In the coast mode, with the brake enabled, the brake will activate when the driver hits the service brake (at or above 1,200 rpm). The brake will deactivate if the driver releases the brake pedal, or if the engine speed drops below 1,200 rpm.

Latched Mode. In the latched mode, with the brake enabled, the braking will activate when the driver's foot is lifted from the accelerator pedal (at or above 1,200 rpm). If the cruise ON / OFF switch is in the ON position (with or without a cruise set speed), the braking is activated by hitting the brake pedal. The braking

action will cease if the driver presses the accelerator, the clutch, or if the engine speed drops below 1,200 rpm.

Cruise Mode. The cruise mode operates the same as the latched mode, except that if the driver has the cruise turned ON, the braking action helps to maintain the set speed. This feature is especially valuable when going down a grade.

Exhaust Aftertreatment

Selective Catalytic Reduction System (If Equipped)

Introduction

Selective Catalytic Reduction (SCR) is the aftertreatment technology that treats exhaust gas downstream of the engine. It uses a urea-based Diesel Exhaust Fluid (DEF) and a catalyst to significantly reduce nitrogen oxide (NOx) emissions.

Diesel Exhaust Fluid

Diesel Exhaust Fluid (DEF) is nontoxic, nonflammable, and biodegradable. It is a carefully blended aqueous urea solution of 32.5% high-purity urea and 67.5% deionized water.

If stored between 10° and 90°F (-12° and 32°C), DEF has shelf life of 12 months minimum. For best shelf life, DEF containers should be stored in a controlled environment out of direct sunlight.

The amount of DEF consumption depends on engine speed and load; therefore, it differs from vehicle to vehicle.



CAUTION

To prevent property damage, IC Bus requires the use of Diesel Exhaust Fluid (DEF) that meets or exceeds ISO-22241-1. There is no acceptable substitute.

IC Bus recommends using Fleetrite® brand Diesel Exhaust Fluid.

DEF Tank

The DEF tank filling inlet is located on the right-side of the vehicle, near the fuel tank door and behind a fill door labelled DEF Fluid. For reference, see Figure Exterior Components in section **Model Description > Exterior Components**.

The filler neck inlet on a DEF tank has a BLUE cap and has a smaller diameter (19 mm) than that of a filler neck on the diesel fuel tank.

The SCR system is designed to operate normally also under freezing conditions while containing DEF. Though DEF freezes at approximately 10°F (-12°C), no operator interaction is necessary when operating in cold temperatures.

Under cold or very dry conditions, water vapor can be seen coming from the vehicle tailpipe. This is normal system operation. The water vapor will disappear within a few minutes of normal vehicle operation.

After the key is turned OFF on a vehicle with SCR system, a pumping sound may be heard from underneath the vehicle. The sound is made by the aftertreatment DEF dosing unit while it purges any unused DEF from the system and returns it to the

DEF tank. This is normal system operation. It takes about 70 seconds to complete.



CAUTION

To prevent vehicle / property damage, after turning the key OFF on a vehicle with Selective Catalyst Reduction (SCR) system, do not disconnect the vehicle batteries while you can hear a pumping sound from underneath the vehicle. The sound may last for about 60 seconds.

Low DEF Level









WARNING

To prevent personal injury and / or death, or damage to property, maintain the adequate Diesel Exhaust Fluid (DEF) level to avoid a loss of engine power and vehicle speed.



On the instrument panel, you can monitor the fluid level using the DEF Level Gauge. You will see additional warnings if the DEF is too low. If DEF level decreases to 2.2% or lower, the engine performance will start to be de-rated by at least 25%. If the DEF level remains 0% for an extended time, the vehicle speed will be limited to 5 mph (8 km/h). Refill the DEF tank with approved DEF at any point, and the vehicle will resume normal operation.

See the following table for a detailed explanation of indicators about low DEF level.

Indicators about Low DEF Level (For Vehicles Equipped with Cummins® B Engines)

Level	Indication	Audible Alarm	Liquid Crystal Display (LCD) Text Message	Vehicle Conditions / Operation
1	 (Solid)	1 beep	Scrolls between SEE VISOR FOR INFO and DEF LOW REFILL SOON.	Initial Warning - normal engine operation. DEF level is 10% or lower.
2	 (Flashing)	1 beep	Scrolls between SEE VISOR FOR INFO and DEF LOW REFILL SOON.	Initial Warning - normal engine operation. DEF level is 5% or lower.
3	 (Flashing)  (Solid)	1 beep	Scrolls between SEE VISOR FOR INFO, DEF LOW ENGINE DERATED 25%, and WARN ENGINE.	Engine performance is LIMITED . DEF level is 2.5% or lower.
4	 (Flashing)  (Solid)	1 beep	Scrolls between SEE VISOR FOR INFO, DEF LOW ENGINE DERATED 40%, and WARN ENGINE.	Engine performance is LIMITED . DEF level is 0%.

Indicators about Low DEF Level (For Vehicles Equipped with Cummins® B Engines) (cont.)

Level	Indication	Audible Alarm	Liquid Crystal Display (LCD) Text Message	Vehicle Conditions / Operation
5	 (Flashing)  (Solid)  (Solid)	1 beep	Scrolls between SEE VISOR FOR INFO, DEF LOW ENGINE DERATED 5MPH, WARN ENGINE, and STOP ENGINE.	Vehicle speed is limited to 5 mph (8 km/h).

DEF Contamination or SCR System Fault



WARNING





To prevent personal injury and / or death, or damage to property, seek service immediately if Diesel Exhaust Fluid (DEF) contamination or Selective Catalyst Reduction (SCR) system fault is detected.

- Failure to resolve the problems may result in a loss of engine power and vehicle speed, and may cause an accident.

If incorrect liquid is in the DEF tank or if some other fault is detected within the SCR system, the Amber Warning Lamp or Malfunction Indicator Lamp will illuminate. If no action is taken in the initial warning stages, engine performance will be derated by at least 25%, and eventually vehicle speed may be limited to 5 mph (8 km/h).







See the following tables for detailed explanation of DEF or SCR system indicators.

Indicators about DEF Quality Problem (For Vehicles Equipped with Cummins® B Engines)



Level	Indication	Audible Alarm	LCD Text Message	Vehicle Conditions / Operation
1		1 beep	Scrolls between DEF QUALITY SERVICE SOON and WARN ENGINE.	Initial Warning - fault code has been set.
2		1 beep	Scrolls between DEF QUALITY DERATED 25% and WARN ENGINE.	Engine performance is derated by at least 25%.
3		1 beep	Scrolls between DEF QUALITY DERATED 40% and WARN ENGINE.	Engine performance is progressively derated by up to 40%.
4		1 beep	Scrolls between DEF QUALITY DERATED 5MPH, WARN ENGINE, and STOP ENGINE.	Engine performance is de-rated by 40%. Vehicle speed is limited to 5 mph (8 km/h).

Operation

Warnings of SCR System Fault (For Vehicles Equipped with Cummins® B Engines)

Level	Indication	Audible Alarm	Vehicle Conditions / Operation
1	 8467084 or  3813053	1 beep	Initial Warning - fault code has been set.
2	 8467084 or  3813053	1 beep	Engine performance is derated by at least 25%.
3	 8467084 or  3813053	1 beep	Engine performance is progressively derated by up to 40%.

Warnings of SCR System Fault (For Vehicles Equipped with Cummins® B Engines) (cont.)

Level	Indication	Audible Alarm	Vehicle Conditions / Operation
4	 <p>8487084</p> <p>or</p>  <p>3813053</p> <p>and</p>  <p>8487086</p>	1 beep	Engine performance is derated by 40%. Vehicle speed is limited to 5 mph (8 km/h).

Exhaust Diesel Particulate Filter Regeneration

This vehicle is equipped with a Diesel Particulate Filter (DPF) to meet 2010 emissions requirements. The DPF traps exhaust particulate matter generated by normal engine usage. Periodically, the engine control system will perform a cleaning of the filter, known as Normal Regeneration. This process is transparent to the operator and occurs during normal vehicle operation.

In some cases the engine control system is unable to manage soot levels in the DPF through Normal Regeneration. When this occurs the DPF indicator will illuminate solid YELLOW on the Instrument Panel Gauge Cluster advising that action must be taken. At this time the vehicle should then be driven at highway speeds, or pulled over to perform a Parked Regeneration (See Parked Regeneration Procedure).

If no action is taken during the previous warning stage, the DPF indicator will begin to flash indicating that the filter is full. The vehicle should then be pulled safely off the roadway and a Parked Regeneration should be performed.

If the vehicle is driven beyond the initial two warning stages, a loss of engine performance (derate) will occur. Ignoring the need for a Parked Regeneration, when required, can result in a warning for excessive exhaust temperatures, and a requirement to shut the engine OFF and not restart it until the DPF has been serviced by a technician. It is important to perform a Parked Regeneration when required. Failure to do so could be mission disabling and result in the vehicle being towed.

See the following information for a detailed explanation of DPF indicators and the corresponding procedures that must be followed.



WARNING

To prevent personal injury and / or death, or damage to property, do not perform a Parked Regeneration when Diesel Particulate Filter (DPF) indicator is ON as this will cause the engine to lose power and eventually shut down.

When performing Parked Regeneration, ensure vehicle is safely off of the roadway and exhaust pipe is away from people, or any flammable materials or structures.



Failure to follow these instructions may result in a loss of engine power and vehicle speed, increased exhaust temperatures, and an accident or fire.

There will be three levels of indication that the vehicle's exhaust filter is accumulating soot and needs to be cleaned, each with an increasing urgency for action.







NOTE: A Level 1 indication may disappear or a Level 2 may revert to a Level 1, if the vehicle is driven on highway at highway speeds for an extended period. This process of auto regeneration of the exhaust filter is activated when the engine load is increased as a result of highway driving at highway speeds. If the DPF indicator does not reduce in level or disappear, a Parked Regeneration must be performed.

NOTE: The following table is a typical representation of 2010 DPF emissions procedures.

Diesel Particulate Filter (DPF) Regeneration Table

Level	Engine Option	Indication	Audible Alarm	LCD Text Message	Vehicle Conditions / Operation	Action Required
1	All	 3813053 (Solid)	None	Scrolls between SEE VISOR FOR INFO and PARKED REGEN REQUIRED.	Exhaust filter regeneration required.	Drive on highway at highway speeds or start parked regeneration to prevent loss of power.
2	All	 3813053 (Flashing)	None	Scrolls between SEE VISOR FOR INFO and PARKED REGEN REQUIRED.	Exhaust filter is full.	Pull vehicle safely off roadway and start parked regeneration to prevent loss of engine power.

Diesel Particulate Filter (DPF) Regeneration Table (cont.)

3	Navistar engines only	 3813053 (Flashing)	An alarm will beep continuously while ignition is on.	Scrolls between SEE VISOR FOR INFO and PARKED REGEN REQUIRED.	Exhaust filter is full. Engine performance is LIMITED .	 WARNING To prevent personal injury and / or death, or damage to property, pull vehicle safely off roadway and start parked regeneration to prevent engine stopping.
	Cummins® B only	 3813053 (Flashing)  8487084 (Solid)				
 TEMP 3813051						
<p>Exhaust System Temperature is HOT</p> <p style="text-align: center;"> WARNING</p> <p>To prevent personal injury and / or death, or damage to property, keep exhaust components away from people and flammable materials, vapors, or structures, and STOP ENGINE. Exhaust components, operating under normal conditions, and exhaust gases are at extremely high temperatures.</p>						
 A serious problem has occurred. Engine may SHUT DOWN soon. Pull vehicle safely of roadway, turn ON flashers, set parking brake, place warning devices, and STOP ENGINE . Seek service immediately.						

Parked Regeneration Procedure

Perform the following steps to initiate Parked Regeneration (cleaning) of the exhaust filter:

1. Park the vehicle safely off the roadway and away from flammable materials.
2. Before initiating parked regeneration (using the ON / PARKD REGEN switch), the following conditions must be in place:
 - a. Parking brake must be set.
 - b. DPF indicator illuminated (Solid or Flashing).
 - c. Transmission must be in Neutral (N) or Park (P), if available.
 - d. Accelerator, foot brake and clutch (if present) pedals must not be depressed.
 - e. Engine temperature must be at a sufficient level to allow regeneration.

With some engines, this may be as high as 170°F (77°C).

NOTE: The engine coolant temperature must be above 77°C (170°F) before the parked regeneration procedure can be performed. If the engine coolant temperature is too low, the parked regeneration procedure will not activate.

3. Press the ON position of the ON / PARKD REGEN switch to initiate the regeneration cycle.

The engine speed will automatically ramp up to a preset rpm, PARKD REGEN ACTIVE will be displayed in the information display, and the switch indicator will illuminate

when the cycle is started. If the indicator is blinking, check to be sure that all conditions in Step 2 have been met. Once started, the regeneration cycle will last approximately 30 minutes.

NOTE: If any of the above conditions are altered during the parked regeneration process, regeneration will be halted and must be restarted.

4. When the regeneration cycle is complete, the switch indicator will go OFF, the engine rpm will return to normal idle and all exhaust filter warning indicators will be OFF. The vehicle may now be driven normally.



NOTE: In the event of an emergency where the vehicle must be moved after beginning Parked Regeneration, press PARKD REGEN position of the ON / PARKD REGEN switch to cancel Parked Regeneration.

Regeneration Inhibit Switch

The optional Regeneration Inhibit switch is used to prevent the normal regeneration or parked regeneration processes.



NOTE: There are two versions of the regeneration inhibit switch: the two-position and the three-position switch. Therefore, it is necessary to verify which version is installed in this vehicle. Both versions have the same switch labels.

Operation

Two-Position Regeneration Inhibit Switch

With the optional two-position switch, pressing the ON position of the ON / INHIBT REGEN switch will inhibit both normal and parked regeneration. Regeneration will be inhibited (latched) when in this position and the switch indicator is turned ON.

Three-Position Regeneration Inhibit Switch

The optional three-position switch is a center stable momentary switch. Pressing the ON position inhibits normal regeneration while the engine is running and is reset when the ignition switch is turned OFF. The Inhibit function is cancelled when the lower position is pressed, or parked regeneration is initiated (PARKD REGEN switch is turned to the ON position).

The switch indicator will be turned ON whenever regeneration inhibit is enabled.

Restarting After Running Out of Fuel

It may be necessary to bleed the fuel system. Refer to Bleeding Air From Fuel System in the **Engine Operation And Maintenance Manual** supplied with your vehicle.

Cold Weather Operation

INSTRUCTIONS



To prevent personal injury and / or death, or damage to property, do not use the washers in freezing weather without first warming the windshield with the defrosters; otherwise, the washer solution may freeze on the windshield and obscure your vision, which could cause an accident.

Do not use radiator coolant or antifreeze in the windshield washer reservoir. Radiator coolant in the washer reservoir can severely reduce visibility when sprayed on the windshield.

Follow these instructions when operating the engine in temperatures of 32°F (0°C) or lower:

- Ensure that the batteries are of sufficient size and are fully charged. Check other electrical components to ensure they are in optimum condition.
- Use a permanent-type engine coolant solution to protect the engine against damage from freezing.
- If your vehicle is equipped with a water-fuel separator, drain it daily. Fill the fuel tank at the end of daily operation to prevent condensation in the fuel system.
- Ensure you use proper cold weather engine oil and that it is at its proper level.

- At temperatures of 4°F (-20°C) or below, it is recommended that you use a crankcase-mounted coolant heater to improve cold engine starting.
- Consult your IC Bus® dealer for information about special cold weather equipment and precautions if operating in arctic temperatures of -20°F (-29°C) or lower.

ENGINE IDLING



CAUTION

To prevent property damage, do not leave diesel engines idling for an extended amount of time in cold weather. Diesel engines are highly efficient, they use very little fuel while idling. As a result, idling in cold weather will not heat the engine to its normal operating temperature. This in turn can cause a buildup of heavy deposits of carbon and rust on valve stems, causing them to stick. Sticking valves can cause significant valve train damage. The colder the ambient temperature, the more likely this will occur.

The following cold weather idling guidelines must be followed:

- Avoid extended idling (beyond 10 minutes) whenever possible. To maximize engine and Diesel Particulate Filter (DPF) life, see Exhaust Diesel Particulate Filter Regeneration in this section for more information.
- Use a minimum 45 Cetane diesel fuel or utilize Cetane Index improvers from a reputable manufacturer.

- Maintain a minimum of 1,250 rpm idle by use of the hand throttle. Always ensure that parking brake is applied and transmission is in Park (P) before applying hand throttle.
- Maintain engine cooling system.
- Do not shut engine down after extended idling period. Drive the vehicle under load for several miles at normal operating temperatures to burn off any accumulated carbon and varnish.
- Consider use of engine block heaters, approved winter fronts and / or radiator shutters where conditions warrant.

WINTER FRONTS

Do not use winter fronts or other air-restrictive devices mounted in front of the radiator with a permanent opening with less than 120 in² (3 m².) directly in line with the fan hub. Air flow restriction can cause high exhaust temperatures, power loss, excessive fan usage, and reduce fuel economy.

Hot Weather Operation

- Keep the engine cooling system filled with clean, permanent coolant solution to protect against damage from overheating.
- Keep external surface of the engine, radiator, charge air cooler and accessories clean to avoid dirt build up.
- Fill fuel tank at end of daily operation to prevent condensation in tank.

Operation

Above normal coolant temperature could be temporarily decreased by down shifting into the next lower gear. This increases engine rpm, which increases coolant flow and air flow through the radiator.

NOTE: If above normal operating temperatures persist, have vehicle serviced at first available opportunity.

Turning OFF the Engine

Allow the engine to idle for 3-5 minutes before shutting it down. This allows the lubricating oil and coolant to carry heat away from the large iron components and the turbocharger, preventing engine damage from rising heat.

Brakes

Downhill Operation

Always descend hills with extreme care. Heed warning signs posted for any grade. Stop and check brakes for condition and adjustment at available pull off areas before starting a descent.

Observe the following precautions:

- Never coast downhill. Service brakes alone should not be used to control speed on major downgrades. Brakes fade from overuse.
- The downhill speed is controlled by removing your foot from the accelerator pedal and putting the transmission in a reduced gear. If the gear selection does not hold the desired speed without overuse of the brakes, an improper gear selection was made.

- Make a full stop. Let the brakes cool, then continue down the grade in a lower gear range.
- The common rule to follow in using the engine and transmission to control vehicle speed is to select the same gear going down the hill that would be required to ascend the hill.
- The service brakes should be used to supplement available vehicle retardation. When descending long grades requiring use of the brakes, short applications (five to ten seconds duration) should be made rather than long, lighter, continuous applications. This minimizes temperature brake fade.

Warning Indicators

Instrument Panel Gauge Cluster indicators identify brake system fault conditions. Certain faults may also result in cluster alarms. The following lists some of the common faults (See fault indicators in Instrumentation section):

NOTE: Whenever a brake system warning indicator is lit, do not operate the vehicle until the faulty condition has been corrected.

- **Brake Pressure.** ON STEADY when either front or rear brake system brake pressure failure is detected. ON STEADY when the system is in backup mode where primary boost is lost (no power steering flow when the engine is OFF).
- **Brake Fluid.** ON steady when low fluid level is detected in master cylinder reservoir.

NOTE: There may be a fault condition that results in more than one warning indicator being lit.

SmartTrac™ Hydraulic Brake Booster System (If Equipped)



To prevent personal injury and / or death, or damage to property, if part of the brake system fails, reduce speed and use caution as stopping distance may increase under the failed condition or if only one section of the brake system is operating. Have brake system repaired immediately. Loss of braking capability could cause an accident.



To prevent personal injury and / or death, or damage to property, if the brake pressure warning indicator comes on while driving, be aware that your stopping distance may be significantly increased. Safely stop the vehicle as soon as possible and have the brake system repaired immediately as reduced braking capability could cause an accident.



To prevent personal injury and / or death, or damage to property, always check and maintain brakes in proper condition and adjustment. Out-of-adjustment brakes could cause reduced braking ability.

The SmartTrac™ system receives fluid pressure from the power steering pump to provide power assist during braking.

The SmartTrac™ hydraulic booster has a backup pump which will provide hydraulic boost at a reduced rate if the normal source of fluid is interrupted. The signal for operation of the backup pump comes from the fluid flow switch or differential pressure switch. If normal flow is interrupted, the flow switch will close and activate the backup pump relay, which will turn ON the backup pump.

If braking performance or pedal response becomes very poor, even when the pedal is strongly applied, this may indicate the presence of air in the hydraulic system or fluid leakage. This may be accompanied by the brake fluid or brake pressure warning lights, indicating that the brake fluid is getting low. Safely stop the vehicle as soon as possible and seek service immediately.

If the brake pressure warning light in the Instrument Panel Gauge Cluster remains illuminated after engine start-up, and an audible tone is heard while the light is illuminated, this indicates a system failure in the brake system. Stop the vehicle as soon as safely possible and seek service immediately.



Operation

Instrument Panel Gauge Cluster indicators identify brake system fault conditions. Certain faults may also result in cluster alarms. The following lists some of the common faults (See **Warning Indicators** in **Instrumentation** section):

Split-System Feature



WARNING

To prevent personal injury and / or death, or damage to property, if part of the brake system fails, reduce speed and use caution as stopping distance may increase under the failed condition or if only one section of the brake system is operating. Have brake system repaired immediately. Loss of braking capability could cause an accident.



WARNING

To prevent personal injury and / or death, or damage to property, under no circumstances should the parking brake chamber be disassembled. Disassembly will release a powerful spring that could result in property damage, personal injury or death.

The system is divided into two separate channels: the primary channel (controls front axle) and the secondary channel (controls rear axle). The brake master cylinder is connected to brake lines that are routed to the front and rear brake channels.

With the split brake system, the operator is has limited brake control should one of the two channels fails. If one of the motor / pump related systems fail, the driver may not detect any difference in the feel of the pedal, but with a failure in the master cylinder circuit, the driver may experience a longer pedal stroke to attain desired stopping. If a brake system failure occurs, one of the Instrument Panel Gauge Cluster warning indicators should illuminate.

Manual Foot Operated Parking Brake System with Hydraulic Brakes



WARNING

To prevent personal injury and / or death, or damage to property, when parking your vehicle, always use the parking brake. When parking on a grade, install wheel chocks and turn front wheels to keep the vehicle from rolling into the traveled portion of the roadway. Failure to follow these procedures could cause an unattended vehicle to move, resulting in property damage, personal injury or death.

The purpose of the parking brake is to hold the vehicle in the parked position. It should not be used to brake the vehicle during normal driving. It may be used to assist in making an emergency stop in the event of service brake failure.

The manual parking brake is controlled by the parking brake pedal. Always observe the Instrument Panel Gauge Cluster PARKING BRAKE indicator to determine if the parking brake is applied or released.

To Manually Apply the Parking Brake

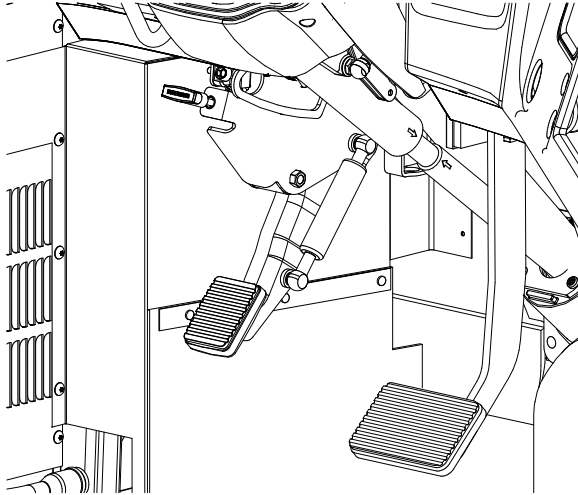

0000362061

1. Bring the vehicle to a complete stop, using your brake pedal.
2. Ensure that the engine is at low idle.
3. With your foot still firmly on brake pedal, place transmission in Park (P) or Neutral (N) position.
4. Firmly push the parking brake pedal. The PARKING BRAKE indicator will illuminate in the Instrument Panel Gauge Cluster.

To Manually Release The Parking Brake

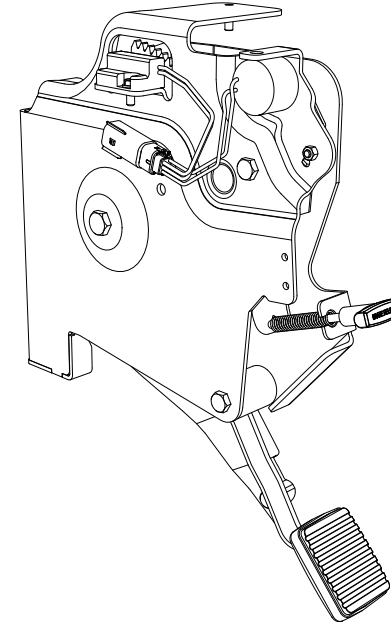

0000362081

1. Turn ignition switch to the ON position,
2. Depress and hold the brake pedal.
3. With the brake pedal held, pull the brake release lever until the parking brake indicator goes out, then release.

Air Brakes



WARNING

To prevent personal injury and / or death, or damage to property, to prevent loss of vehicle braking or control resulting in property damage, personal injury or death, never operate the vehicle when insufficient air pressure (less than 70 psi [483 kPa]) is indicated for either the primary or secondary air system, or if a low-pressure alarm is sounding and a warning indicator is illuminated. The volume of air required to stop the vehicle may be greater than that available. Have the brake system checked and repaired before returning the vehicle to service.

All air brake equipped vehicles have a split brake system. A split system provides a way to stop the vehicle if a failure occurs in either the primary or secondary brake system. If air pressure is lost in one system, the remaining system continues to provide braking action.

Even though there is braking capability for emergency stopping, do not operate the vehicle when a failure is indicated, because there may be no way of replenishing air pressure.

If vehicle has been parked for an extended period in cold weather, always check to be sure all wheels are rolling free (brakes are not frozen) when starting out. Always clean accumulated ice and snow from brake linkage.

If air pressure in either section of the split air brake system is reduced to 57psi (393 kPa) the warning buzzer will sound and

a RED air pressure indicator on the Instrument Panel Gauge Cluster glows. In addition, the air gauge(s) will indicate low air pressure in at least one of the split systems.

The warning buzzer and RED air pressure indicator automatically shut OFF when the air pressure in both systems is sufficient (approximately 70 psi [483 kPa]) to operate the vehicle.

If the RED air pressure indicator and buzzer do not shut OFF after startup, check the air pressure gauge(s) and see if one or more sections of the split system has low air pressure.

If the RED indicator, buzzer, and gauge indicate a loss of pressure while driving, the vehicle will still have some braking capability. Either one-half of the split system or the spring brake system braking capability is retained. However, the distance required to stop the vehicle will be increased.

Air Disc Brakes (0004JBZ, 0004JCC, 0004WEY, 0004WEZ)

The air disc brake system encompasses a floating caliper design that is activated when air pressure is introduced into the system.

The air disc brake system works by converting air pressure into braking force. When braking is applied, air will enter the brake chamber, applying pressure to the diaphragm. The pressure created activates the system causing the brake pads to contact the rotor. When braking is released, the air pressure in the brake chamber is released, exhausting the pressure on the diaphragm, causing the brake pads to return to their neutral / non-braked position.

Using Air Brakes



WARNING

To prevent personal injury and / or death, or damage to property, always check and maintain brakes in proper condition and adjustment. Out-of-adjustment brakes could cause reduced braking ability.

Do not apply and release (pump) the brakes rapidly. This is an inefficient way of slowing or stopping a vehicle and inefficient use of air pressure. This also reduces the ability of the ABS system to function properly.

Using the Air Parking Brake



WARNING

To prevent personal injury and / or death, or damage to property, before starting the engine, the parking brake control knob must be in the applied (pulled) position. Failure to do so could allow the vehicle to roll.

The purpose of the parking brake is to hold the vehicle in the parked position. It should NOT be used to brake the vehicle during normal driving. It may be used to assist in making an emergency stop in the event of service brake failure.

Parking Brake / Wheelchair Lift (Optional) Interlock. On vehicles equipped with an optional wheelchair lift, power will not be supplied to the wheelchair lift mechanism unless the parking brake is applied.

NOTE: On vehicles equipped with optional wheelchair lift, the parking brake cannot be released until the wheelchair lift is completely stowed.

NOTE: For a complete description of these interlocks, see the Parking Brake / Wheelchair Lift (if equipped) Interlock procedures in the Hydraulic Brake section.

To Engage Air Parking Brake

1. Bring the vehicle to a complete stop, using your brake pedal.
2. Ensure the engine is at low idle.
3. With your foot still firmly on brake pedal, place transmission in neutral position.
4. Pull the parking brake control knob to apply the parking brake.

To Release Air Parking Brake

1. Have the engine running and your foot on the service brake pedal.
2. Push in the control knob.
3. Wait until system pressure has reached 70 psi.

NOTE: DO NOT operate vehicle until system pressure has reached 70 psi.

NOTE: To release the parking brake on vehicles with the optional wheelchair lift, the lift must be completely retracted and stowed.

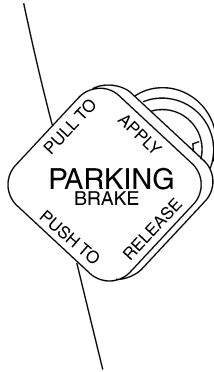

ICB100155

Air Parking Brake Control Knob

Air Brake Gauge



The air operated parking brake has an air gauge and warning buzzer. When pressure in the parking brake air reservoir has been reduced to about 57 psi (393 kPa), the buzzer sounds.

A loss of pressure in the control circuit prevents normal operation of the parking brake.



CAUTION

To prevent property / vehicle damage, if air system pressure falls below 70 psi (483 kPa), pull off the roadway, apply the parking brake and correct the low pressure condition.

If air pressure is reduced to approximately 40 psi (276 kPa) in both the primary and secondary systems, the parking brakes will automatically apply.

Parking Brake Indicator Light

The parking brake indicator is illuminated when the parking brake is applied. During engine cranking period the parking brake indicator should illuminate. This indicator goes out after the engine is started if the parking brake is not applied. If the parking brake is applied, this indicator remains on after engine has started. If the indicator does not illuminate during cranking period, the light bulb may be defective.

Parking Brake / Wheelchair Lift Interlock and Alarm

On vehicles equipped with an optional wheelchair lift, the following will describe the optional parking brake / wheelchair lift interlock and parking brake / wheelchair lift alarm. Read and understand these paragraphs and the wheelchair lift manufacturer's Operation Manual before operating the Wwheelchair lift.

Power will not be supplied to the wheelchair lift mechanism unless all of the following steps have been performed.

Wheelchair Lift Extension Operation

1. Ensure that the ignition switch is in the ON or ACC (Accessory) position.
2. Place transmission shift lever in Parking Brake (PB), Park (P), or Neutral (N) position.
3. **For Air Brakes**, pull parking brake knob (Park indicator on Instrument Panel Gauge Cluster will turn ON).
4. **For Hydraulic brake**, Apply the parking brake.
5. Open the wheelchair lift door.

The wheelchair lift can now be operated (according to the manufacturer's Operation Manual instructions). The LIFT DOOR Instrument Panel Gauge Cluster indicator turned ON and will remain ON as long as the wheelchair lift door is opened.

PARK

ICB100022

Parking Brake / Wheelchair Lift Interlock—Retracting and Stowing Operation

The vehicle cannot be moved (the parking brake cannot be released), until the following operations are performed.

1. Turn ignition ON.
2. Retract and stow the Wheelchair Lift. The LIFT DOOR Instrument Panel Gauge Cluster indicator will be turned OFF.
3. Close the lift door.
4. Depress the service brake and press and hold the button on the gearshift lever handle and select R (Reverse) or D (Drive) position.
5. **For Air Brakes**, push in on the parking brake knob (Park indicator on Instrument Panel Gauge Cluster will turn OFF).
6. **For Hydraulic Brakes**, pull the parking brake release lever.
7. Lift foot from the brake pedal, and then slowly press the accelerator pedal.

Parking Brake / Wheelchair Lift (Optional) Alarm

- The Instrument Panel Gauge Cluster alarm will beep continuously if the wheelchair lift door is extended **AND**
- The parking brake is released.

Operation

NOTE: When either the parking brake is applied, or the Wheelchair lift door is closed, the Instrument Panel Gauge Cluster alarm will immediately stop beeping.

Antilock Braking System (ABS)



WARNING

To prevent personal injury and / or death, or damage to property, Antilock Brake Systems (ABS) are designed to enhance overall vehicle safety when a vehicle is driven within its safe operating limits. ABS cannot compensate for a vehicle that is being driven beyond the physical limits of control. Drivers operating an ABS-equipped vehicle should employ safe driving practices and assume no additional driving risks.



WARNING

To prevent personal injury and / or death, or damage to property, do not rely on the Antilock Brake System (ABS) to interrupt vehicle engine brake on slippery road surfaces. Turn these devices OFF during hazardous driving conditions. Failure to follow this warning may cause wheel slippage and / or loss of vehicle control.



WARNING

To prevent personal injury and / or death, or damage to property, if the Antilock Brake System (ABS) warning indicator comes on, have the ABS repaired immediately as stopping distances may increase under certain braking conditions. Take every precaution to prevent wheel lockup, which could result in loss of vehicle control.



CAUTION

To prevent damage to the electrical system or ABS components, when welding on an ABS-equipped vehicle, disconnect the power connector from the Engine Control Module (ECM). Failure to heed this caution may result in vehicle and / or engine component damage.

The ABS system is a mandated system used with the Hydraulic and Air Brake systems. The antilock brake system electronically monitors vehicle wheel speed, and only engages when wheel lock is imminent. The standard brake system controls normal braking when the ABS is not engaged. ABS requires few changes in driving practices. For the best stopping performance, press, do not pump the brake pedal until the vehicle slows to desired speed or stops.

The ABS system cannot provide any better braking and steering capability than the available road traction permits. If the road is slippery, it takes longer to stop than on a dry road. Steering maneuverability is similarly limited. Vehicle speed must be reduced to compensate for the extended time and distance required to stop or slow the vehicle on slippery roads. ABS prevents lockup of controlled wheels if you over brake for existing road conditions.

The wheel hubs carry exciter rings used by the axle mounted sensors to transmit wheel speed information to the ABS electronic control unit located on the chassis frame. The control unit monitors and compares all wheel speed inputs to determine if any wheel(s) are about to lock. If wheel lockup is about to occur, the control unit commands the appropriate modulator valve to adjust pressure delivery to prevent wheel lockup.

If over-braking causes wheel lockup on the rear drive axles while retarding devices are in operation, the ABS will interrupt and disable the retarder until the lockup situation has stopped.

The ABS is equipped with a warning indicator located in the vehicle's Instrument Panel Gauge Cluster. Each time the ignition is turned ON the ABS performs a self check. The ABS warning indicator will illuminate and if the ABS passes the self check, the indicator will turn OFF a few seconds after the ignition is turned ON. ABS fault codes will be electronically stored in the ABS.

Antilock Driving Tips

- Use controlled, even pressure to stop the vehicle, being careful not to skid. Most effective stopping will be achieved in this situation.

- If the vehicle begins to skid, maintain even pressure on the brake pedal. The ABS controller will rapidly cycle the brakes on the skidding wheel(s), while maintaining even pressure on the non-skidding wheels.
- While maintaining even pressure on the brake pedal, steer around any hazardous objects in your path.
- Attempt to steer clear of traffic, pedestrians or other obstacles while you are in an emergency braking situation. The antilock brake system will allow you to steer the vehicle during braking while it comes to a full stop. ABS is not an excuse to take unnecessary risks. Always drive carefully and stay a safe distance away from the vehicle in front of you.
- Do not pump the brake pedal during a skid unless the ABS system is not functioning.

ABS Self-Check

NOTE: If an antilock fault develops, standard brake system operation is maintained. The brake system is still operational, but the antilock system does not operate to prevent wheel lockup if you over apply the brakes for existing conditions.

NOTE: If the ABS indicator stays illuminated or continues to flash, have the system serviced immediately.

Operation

A YELLOW warning indicator on the instrument panel indicates the status of the ABS. Each time the ignition is turned ON the indicator comes ON and the system goes through an ABS self-check sequence. If the system is working normally when the ignition is turned ON, the ABS indicator comes ON then flashes twice, and finally the ABS indicator remains ON for several seconds before turning OFF.

Pedal Adjustment Switch (If Equipped)

The pedal adjustment switch (optional) allows the operator to reposition the power-adjustable pedals to enhance comfort and safety. The pedals can be repositioned closer to or further away from the operator. For more information on pedal switch operation, refer to the **Driver Controls** section of this manual.

Manual Pedal Adjustment

Adjustment of brake pedal free travel should not be necessary. In the event adjustment is necessary, it is extremely important that the work be properly performed. Allow only qualified technicians to perform this operation.

Traction Control



To prevent personal injury and / or death, or damage to property, drivers operating a Traction Control equipped vehicle should employ safe driving practices and assume no additional driving risks. Traction Control systems are designed to enhance overall vehicle safety when a vehicle is driven within its safe operating limits. Traction Control cannot compensate for a vehicle which is being driven beyond the physical limits of control.

Your vehicle may be equipped with an optional Traction Control system which helps you maintain the stability and steerability of your vehicle, especially on snow- or ice-covered roads and gravel roads. It reduces engine power and / or selectively applies the rear brakes. The system allows your vehicle to make better use of available traction in these conditions by also limiting the engine rpm when you push further on the accelerator, which limits wheel spin. The TRAC CTRL indicator in the Instrument Panel Gauge Cluster will illuminate during this Traction Control event. The TRAC CTRL indicator will also illuminate if the system is malfunctioning.



0000419425

NOTE: The traction control braking (ATC action) to limit wheel spin does not occur at vehicle speeds above approximately 31 mph (50 km/h). Therefore, at speeds above 31 mph (50 km/h), all ATC events are controlled only by Engine Power Limiting.

The Traction Control switch. If the system is enabled (traction control switch in the TRAC ENAB position), the TRAC CTRL indicator in the Instrument Panel Gauge Cluster will flash during a traction control event and the engine may not increase rpm when you push further on the accelerator. If the traction control switch is in the DISAB position, the traction control system is disabled.



The Off Road switch for Air Brake equipped vehicles. With the traction control switch in the TRAC CTRL position, the system operates as described above. The OFF ROAD position provides modified system performance for off-road conditions. If the optional Off Road switch is in this position, the Instrument Panel Gauge Cluster TRAC CTRL indicator will flash.

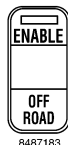

The Mud / Snow switch for Hydraulic Brake equipped vehicles. With the traction control switch in the TRAC CTRL position, the system operates as described above. The MUD / SNOW position of the traction control switch provides modified system performance for deep mud or snow conditions. If the optional Mud / Snow switch is in the activated position, the Instrument Panel Gauge Cluster TRAC CTRL indicator will flash.

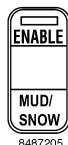

Driver Assist Systems

There are various driver assist systems that could be configured on your bus. The driver assist systems are safety features that assist the driver in various driving conditions.

Bendix® Wingman® Advanced™ Collision Warning System



To prevent personal injury and / or death, or damage to property, the Bendix® Wingman® Advanced™ Collision Warning System is not to be used or relied upon to operate a vehicle. The system should be used in conjunction with rear view mirrors and other instrumentation to maintain safe operation. A vehicle equipped with the Bendix® Wingman® Advanced™ Collision Warning System should be operated in the same safe manner as if the system were not installed. The system is not a substitute for normal safe driving procedures. It will not compensate for any driver impairment, such as drugs, alcohol, or fatigue. The Bendix® Wingman® Advanced™ Collision Warning System is intended solely as an aid for an alert and conscientious professional driver.



WARNING

To prevent personal injury and / or death, or damage to property, before using this feature, read and thoroughly understand the Bendix® Wingman® Advanced™ Collision Warning System's Driver Instruction Manual, and obtain proper training on the system.



WARNING

To prevent personal injury and / or death, or damage to property, be aware that the Bendix® Wingman® Advanced™ Collision Warning System may provide little or no warning for some hazards, such as pedestrians, animals, oncoming vehicles, and cross traffic.

The optional Bendix® Wingman® Advanced™ Collision Warning System combines adaptive cruise control with braking feature

along with collision mitigation technology to assist the driver in various conditions. The system includes the following features:

- **Alerts**
 - **Following Distance** – Provides audible and visual alerts that let the driver know when getting too close to forward vehicle
 - **Impact** – Provides audible and visual alerts warning the driver that a collision with the forward vehicle is likely and that they should address the situation immediately
 - **Stationary Object** – Provides audible and visual alerts that provide the driver up to a 3.0 second alert when a metallic object(s) may be blocking lane of travel

- **Adaptive Cruise Control with Braking** – When cruise control is on with the speed set, the adaptive cruise control helps the driver maintain a set following distance behind a forward vehicle by automatically utilizing the engine retarder and foundation brakes.
- **Collision Mitigation** – Provides audible and visual alerts to the driver and applies the foundation brakes when the system determines a collision with a forward, moving vehicle is imminent. The intervention can be up to two-thirds of the vehicle's braking capacity. Immediate driver action is required to potentially avoid or lessen the severity of a collision.

For more information regarding the Bendix® Wingman® Advanced™ system, visit <http://www.bendix.com>.

Bendix® Wingman® Fusion™ System



To prevent personal injury and / or death, or damage to property, before using this feature, read and thoroughly understand the Bendix® Wingman® Fusion™ System's Driver Instruction Manual, and obtain proper training on the system.



WARNING

To prevent personal injury and / or death, or damage to property, be aware that the Bendix® Wingman® Fusion™ System may provide little to no warning or stationary vehicle braking for some hazards, such as pedestrians, animals, oncoming vehicles, and cross traffic.



WARNING

To prevent personal injury and / or death, or damage to property, the Bendix® Wingman® Fusion™ System is not to be used or relied upon to operate a vehicle. The system should be used in conjunction with brakes, rear view mirrors, and other instrumentation to maintain safe operation. A vehicle equipped with the Bendix® Wingman® Fusion™ System should be operated in the same safe manner as if the system were not installed. The system is not a substitute for normal safe driving procedures. It will not compensate for any driver impairment, such as drugs, alcohol, or fatigue. Please refer to the Bendix® Wingman® Fusion™ Operation Manual for additional warnings, system operation, and system limitations. The Bendix® Wingman® Fusion™ System is intended solely as an aid for an alert and conscientious professional driver.

The Bendix® Wingman® Fusion™ option utilizes the features of the Bendix® Wingman® Advanced™ system in addition to the features below:

- Stationary vehicle braking
- Lane departure warning
- Traffic sign recognition

Visual and audible alerts are provided by the Driver Interface Unit located in the instrument panel where it is easily visible and accessible. Refer to the **Manufacturer Instruction Manual** for complete operating instructions.

This system utilizes a camera and radar in the front of the vehicle to detect other vehicles and hazardous situations. In order for the system to operate effectively, it must be free and clear of debris (snow, ice, etc...). Ensure that the radar and camera is clear of any material that could enable proper function.

For more information regarding the Bendix® Wingman® Fusion™ system, visit <http://www.bendix.com>.

Stability Control Systems – Bendix® Electronic Stability Program (ESP)



WARNING

To prevent personal injury and / or death, or damage to property, do not rely on the stability control systems while driving in hazardous conditions such as rain, snow / ice, gravel, and other loose surfaces. Use caution and safe driving practices when maneuvering in these conditions.



WARNING

To prevent personal injury and / or death, or damage to property, Stability Control systems are designed to enhance overall vehicle stability by automatically reducing vehicle speed under certain conditions. Drivers operating a Stability Control equipped vehicle should employ safe driving practices and assume no additional driving risks.



CAUTION

To prevent property damage, modification to vehicles equipped with stability control systems require prior approval through Navistar or the stability control system manufacturer. Unapproved modifications may result in diminished stability control performance.

NOTE: This section gives a brief explanation of the Electronic Stability Control system, for more information refer to <http://www.bendix.com>

The stability control system provides the core ABS function, as well as Automatic Traction Control (ATC) and roll stability functions.

Core ABS Functions: The core ABS system reduces wheel lockup to help drivers maintain steering control while braking. Antilock Braking Systems (ABS) use wheel speed sensors, ABS pressure modulator valves, and an Electronic Control Unit (ECU) to control either four or six wheels of a vehicle. ECUs optimize slip between the tire and the road surface by monitoring individual wheel turning motion during braking.

Yaw Control: This function reduces the tendency of the vehicle to spin or jackknife when an under-steer or over-steer event occurs.

Vehicle Stability Control Speed Reduction: In the case of a potential roll event, the stability system will remove the throttle and quickly apply brake pressure to slow the vehicle combination below the threshold.

Steering Angle Sensor: This sensor enables the advanced stability system to capture the driver's steering input and intervene if a yaw correction is needed. The sensor also provides the earliest indication of an increase in lateral acceleration that might cause a potential roll event. A steering angle sensor provides a greater stability margin than a vehicle that is not equipped with this sensor.

Brake Demand Sensors: The stability control system was designed to supplement the driver's actions. By directly measuring driver brake demand, the system can transition seamlessly between driver-intended and system-intended braking pressure. For example, if during a certain maneuver, the system calculates 40 psi (276 kPa) is needed and the driver is only applying 20 psi (138 kPa), the system compensates automatically to deliver the needed 40 psi (276 kPa). If, however, during the same maneuver, the driver steps on the brake pedal quickly to apply a higher [above 40 psi (276 kPa)] braking level, the driver's braking input overrides the temporary change made by the system.

ABS / Stability System Interaction: With the ABS-based stability control system, the ABS system is given priority at the wheel ends to manage wheel slip for optimal braking. The ABS system functions similarly whether the stability system or the driver applies the brakes.

International® Ride Optimized Suspension (IROS) (If Equipped)



To prevent property damage, do not operate a vehicle without air in the suspension springs. Operating the vehicle without air in the air suspension springs will damage the suspension, degrade ride performance and may cause transmission damage.

The suspension system automatically adjusts to different loads to maintain a constant frame height. The system allows for ease of vehicle loading and provides improved vehicle ride and increased driver comfort. The system is completely automatic.

Automatic Transmission Operation

Standard Allison 1000 PTS Transmission



To prevent personal injury and / or death, or damage to property, hold the brake pedal down while you move the gearshift from position to position to prevent unexpected vehicle movement.



To prevent personal injury and / or death, or damage to property, check to see that area behind vehicle is clear of people, animals, and objects before backing up. Use a spotter whenever possible and always keep that person in sight. If so desired, backup alarms are available through your IC Bus® dealer. However, they are never a substitute for the above procedures.

NOTE: For complete transmission operation, refer also to separate Allison Transmission Operation Manual.

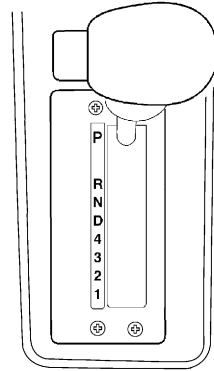

3813041

Allison Transmission Mechanical Lever Shifters

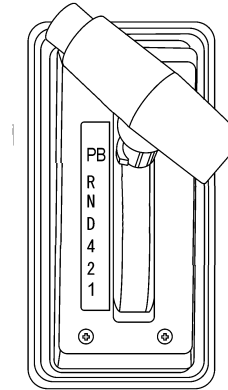

1. Apply the service brake and press and hold the button on the gearshift lever handle.
2. With the brake still applied, continue to hold the gearshift lever button while moving the gearshift lever to Reverse (R) or Drive (D) position, and then release the button.
3. **For Air Brakes**, push in on the parking brake knob (Park indicator on Instrument Panel Gauge Cluster will turn OFF).
4. **For Hydraulic Brakes**, pull and hold the parking brake knob or depress the manual parking brake pedal to apply parking brake (Park indicator on Instrument Panel Gauge Cluster will turn OFF).

Operation

5. Lift foot from the brake pedal, and then slowly press the accelerator pedal.

Allison Generation IV T-Bar Gearshift Control



WARNING

To prevent personal injury and / or death, or damage to property, hold the brake pedal down while you move the gearshift from position to position to prevent unexpected vehicle movement.

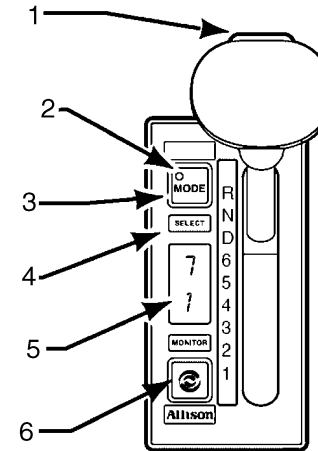

3813023

1. Hold override button
2. Mode indicator (LED)
3. Mode button
4. Mode ID
5. Digital display
6. Display mode diagnostic button

To shift out of R (Reverse) or between any other gear range, first push and hold the gearshift lever button while moving the selector control to the desired gear range.

When the vehicle is started, the transmissions are designed to operate in the standard performance mode. Pressing the MODE button on the shift tower will switch the transmission to economy mode and illuminate MODE ON in the shift tower display. Economy mode provides operation at a lower engine rpm while maintaining adequate performance.

If the engine speed is above idle when a gear is selected with the shift tower, the vehicle will not launch. To move the vehicle, the shift tower must be moved to reselect a gear after the engine comes down to idle.

For further information on the Allison transmission, refer to the separate **Allison vocational transmission model Operation Manual**.

Allison Generation IV Push-Button Shift Selector

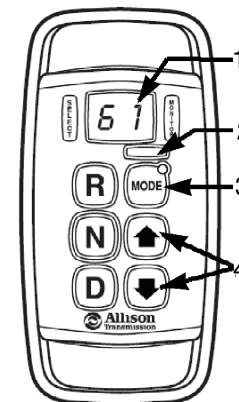

3813024

1. Digital display
2. Mode ID
3. Mode button
4. Range selector button (2)

To shift the transmission into R (Reverse) or D (Drive), press the brake pedal, then press R or D, then release the brake pedal.

To select a lower range when in D (Drive), press the DOWN arrow button.

To select a higher range when locked in a lower range, press the UP arrow button.

To place the transmission in N (Neutral), press N.

Parking the Vehicle.

1. Use your brake pedal to bring the vehicle to a complete stop.
2. Ensure the engine is at low idle.
3. Move the transmission shifter to the PB (Parking Brake), P (Park) or N (Neutral). With the Push Button shifter, press the N (Neutral) button.
4. **For Air Brakes**, pull the parking brake knob (Park indicator on Instrument Panel Gauge Cluster will turn ON).
5. **For Hydraulic brake**, pull and hold the parking brake knob or depress the manual parking brake pedal to apply parking brake (Park indicator on Instrument Panel Gauge Cluster will turn OFF).

An **(Optional)** feature provides for the Hydraulic parking brake to be automatically applied (Auto-Apply) when the transmission shift lever is moved to the PB (Parking Brake) or P (Park) position.

6. Slowly remove your foot from brake pedal and ensure that the parking brake is properly engaged. (The Instrument Panel Gauge Cluster PARK indicator will turn ON.)

Eaton® Procision™ Transmission

The Eaton Procision dual-clutch automatic transmission combines the gear efficiency of a manual with the smooth shifting of an automatic. It consists of two independent but interlocked manual transmissions, each with its own independent clutch. Electronically controlled and hydraulic-actuated gear changes are achieved by preselecting the correct gear and swapping torque between the two clutches. The result is smooth and continuous delivery of torque to the wheels.

The Eaton Procision offers a host of features designed to instill confidence and maximize efficiency:

- Brake-pedal-actuated Tap Down Shifting gives the driver more control by downshifting on grades or other conditions without removing hands from the wheel or eyes from the road.
- Hill Helper technology prevents roll back or roll forward for up to 3 seconds, based on grade and vehicle weight, for a controlled launch.
- Creep Mode allows controlled low-speed parking lot and loading dock driving without applying the accelerator. Forward and Reverse creep speeds are independently adjustable to allow a lower speed in Reverse.
- Eaton Dynamic Shifting uses grade, vehicle weight and driver demand to select optimum shift points for balance of economy and performance

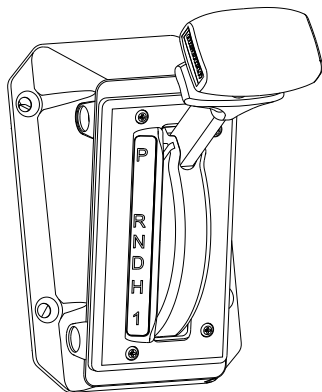

0000387974

Eaton Precision Transmission Gearshift Lever

1. Apply the service brake and press and hold the button on the gearshift lever handle.
2. With the brake still applied, continue to hold the gearshift lever button while moving the gearshift lever to Reverse (R) or Drive (D) position, and then release the button.
3. **For Air Brakes**, push in on the parking brake knob (Park indicator on Instrument Panel Gauge Cluster will turn OFF).
4. **For Hydraulic Brakes**, pull and hold the parking brake knob or depress the manual parking brake pedal to apply parking brake (Park indicator on Instrument Panel Gauge Cluster will turn OFF).

5. Lift foot from the brake pedal, and then slowly press the accelerator pedal.

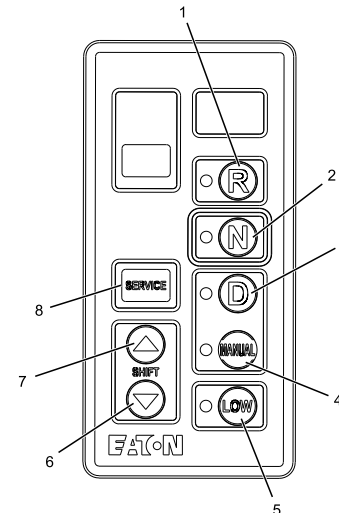

0000387982

Eaton Precision Transmission Push-Button Selector

1. Reverse button
2. Neutral button
3. Forward gear selector button
4. Hold button
5. Low gear button
6. Downshift button
7. Upshift button
8. Service indicator

Operation

The Eaton Procision is a partially automated transmission that automatically selects and engages the proper transmission gears. Some vehicles are equipped with an optional clutch pedal that must be used when starting and stopping the vehicle.

To shift the Eaton transmission into Reverse (R) or Drive (D), first place foot on the brake and optional clutch pedal. When in Drive (D), the transmission selects the starting gear and automatically selects the proper gears for operating loads. To select a higher or lower gear, first press the HOLD button and use either the up arrow or down arrow shift buttons. If LOW is selected while the vehicle is stopped, the transmission will remain in LOW gear until another gear is selected. If selected while in motion, the transmission will downshift when it is safe to do so. To place the transmission in Neutral, press the (N) button.

Parking the Bus With Transmission Shift / Wheelchair Lift Interlocks



WARNING

To prevent personal injury and / or death, or damage to property, always set the parking brake when operating the wheelchair lift, or unexpected and sudden vehicle movement may occur.

Read and understand these paragraphs, along with the wheelchair lift manufacturer's Operator Manual before operating the wheelchair lift. On vehicles equipped with an optional Wheelchair Lift, the optional Transmission / Wheelchair Lift Interlock provides that power will not be supplied to the

wheelchair lift mechanism, and therefore, the wheelchair lift cannot be operated until the previous steps have been completed.

Wheelchair Lift Extension Operation

After the bus has been safely parked (see previous steps):

1. Open the wheelchair lift door (LIFT DOOR Instrument Panel Gauge Cluster indicator should be turned ON).
2. Extend the wheelchair lift (according to the Manufacturer's Operator Manual instructions). The LIFT DOOR Instrument Panel Gauge Cluster indicator turned ON and will remain ON as long as the wheelchair lift door is opened.

Starting Bus in Motion

To start the bus in motion:

1. Depress the brake pedal and press and hold the button on the gearshift lever handle and move the gearshift lever from Park (P) to Reverse (R) or Drive (D) position, and then release the button.
2. Release the parking brake (push and release the parking brake knob or pull the manual parking brake release lever), lift foot from service brake, and then slowly press the accelerator pedal. (The Instrument Panel Gauge Cluster PARK indicator should be turned OFF.)

Starting Bus in Motion With Transmission Shift / Wheelchair Lift Interlocks

Read and understand the wheelchair lift manufacturer's Operator Manual before operating the wheelchair lift.

On vehicles equipped with an optional wheelchair lift, the optional Transmission / Wheelchair Lift Interlock will prevent shifting out of the Parking Brake (PB) , or Park (P) position, until the wheelchair lift door is closed. This will prevent the vehicle from being moved while the wheelchair lift is still extended. For a description of the wheelchair lift retraction and stowing operation, go to the passenger control section.

Retracting and Stowing Operation

After using the wheelchair lift to load passengers and before you can start the bus in motion, (shifting the gearshift lever out of the P [Park] position), retract and stow the wheelchair lift and then close the lift door (LIFT DOOR gauge cluster indicator should be turned OFF).

When the wheelchair lift has been safely stowed (according to the wheelchair lift Manufacturer's Operator Manual instructions), the bus can be safely moved as follows:

- Depress the brake pedal and press and hold the button on the gearshift lever handle and move the gearshift lever from Park (P) to Reverse (R) or Drive (D) position, and then release the button.

- Release the parking brake (push and release the parking brake knob or pull the manual parking brake release lever), lift foot from service brake, and then slowly press the accelerator pedal (the Instrument Panel Gauge Cluster PARK indicator should be turned OFF).

Backup Alarms

This bus may be equipped with one of two backup alarms options to warn anyone standing behind the vehicle that it is in the process of backing up. The backup alarm is activated by:

Reverse gear Alarm Option. With foot on brake pedal, shift the transmission into R (Reverse). **The backup alarm will sound as long as the transmission shift selector is in the R (Reverse) position.**

Roll Back Alarm Option. Release the parking brake and then take your foot off the service brake pedal, allowing the bus to drift backward. **The backup alarm will sound as soon as the bus begins to roll backward.**

NOTE: This optional backup alarm is activated every time the vehicle moves backwards, in any gear, with the ignition ON or OFF.

Economy Mode

The Economy mode provides a transmission shift schedule for improved fuel economy. To activate this mode, switch the ECON / ON switch, on the right switch panel, to the ON position. When in the ON position the switch indicator will be turned ON.

Operation

Automatic Transmission Operating Temperatures

Your vehicle may be equipped with a warning indicator or gauge that will indicate high transmission fluid temperatures.

The sump / fluid reservoir temperatures of the Allison Transmissions should not exceed 250°F (120°C).

SECTION 10 — ROADSIDE EMERGENCIES

Hazard Warning Switch



WARNING

To prevent personal injury and / or death, or damage to property, if engine shutdown occurs, if possible, ensure that vehicle is safely off the roadway, turn ON 4-way emergency flashers, and properly place warning devices.

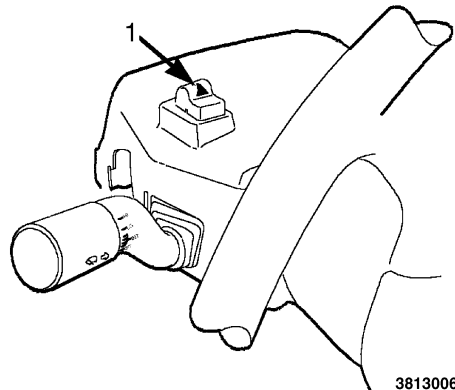

Use the hazard warning light switch in an emergency to warn traffic of vehicle breakdown, approaching danger, the vehicle is in tow, or is operating at a reduced speed.

Press the button to activate all hazard flashers simultaneously.

Press the button again to turn OFF the flashers.

Emergency Equipment (Recommended On-Board)

Fire Extinguisher

Inspect the fire extinguisher monthly to ensure it has a sufficient charge. Look at the gauge located at the top of the extinguisher to verify proper charge.



ICB100515

Roadside Emergencies

First Aid Kit



ICB100512

Ensure to keep the first aid kit completely stocked and ready for use at all times by replacing any items used.

Body Fluid Cleanup Kit



ICB100513

Use this whenever any type of body fluid comes in contact with the bus. When items are used, they should be immediately replaced.

Reflective Triangle

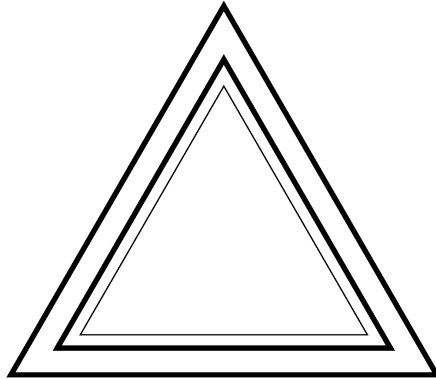

ICB100514

Use the triangle whenever the bus is pulled over to the side of the road. The reflective triangle kit is usually located behind the driver's seat. After opening the kit, unfold the triangle and ensure it locks in place.

Fuse / Circuit Breaker Charts

NOTE: To gain access to the fuse and circuit breakers, reference for the location of the Electrical Compartment Access Panel.

The following fuse illustrations represent typical fuse panel layouts. The actual vehicle fuse panels will vary depending on the vehicle options.

Chassis Fuse / Circuit Breaker Chart

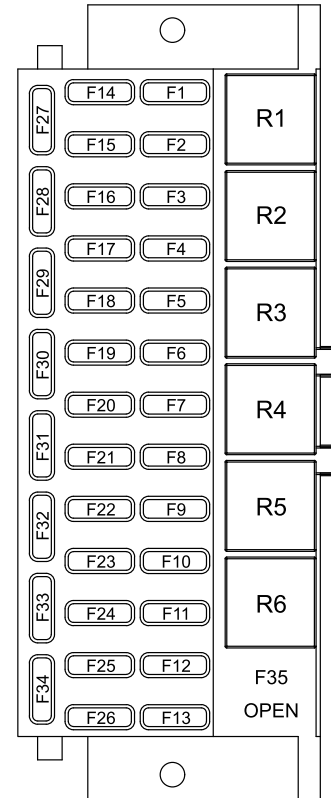

0000374185

Roadside Emergencies

Location	Size	Description
F1	10A	Crossing Gate
F2	15A	Instrument Panel Gauge Cluster Battery Feed
F3	5A *	Hydraulic Brake Switch Battery Feed
F4	10A	Ammeter / Crossing Gate Battery Feed
F5	10A	Stop Light Relay Battery Feed
F6	30A	Air Conditioner Blower Motor
F7	10A	Key Switch Battery Feed
F8	3A	Ignition #1 Relay
F9	10A	Diagnostic Connector Battery Feed
F10	30A	Ignition #2 Relayd
F11	5A*	Body Builder / NEC GPS Prewire
F12	5A*	System Controller / Switch Pack Accessory Feed
F13	5A*	Aware
F14	5A*	Body Builder Ignition Feed
F15	10A	Compass Module / Aware
F16	10A	System Controller Ignition Feed
F17	5A*	Engine Electronics Ignition Feed
F18	5A*	Accelerator Pedal Ignition Feed

Location	Size	Description
F19	5A*	Auto Drain Valve Relay Ignition Feed
F20	10A	Back up Light Ignition Feed
F21	10A	Transmission Control Module Ignition Feed / 12V Crank Relay
F22	5A*	Transmission Shifter LCT / Eaton Hybrid HCM2
F23	10A	Fuel Heater / Air Dryer / Drain Valve / Park Regen Switch Ignition Feed
F24	5A*	Instrument Panel Gauge Cluster Ignition Feed
F25	5A*	Bendix and WABCO Hydraulic Antilock Brake System
	10A*	WABCO Air Antilock Brake System
F26	5A*	Panel Light System
F27	10A	Brake Monitor Ignition Feed
F28	5A*	Air Conditioner Clutch
F29	5A*	Change Transmission Filter Ignition Feed
F30	5A	WTEC Shift Selector / Eaton Hybrid TECU
F31	10A	Fan / Shutter
F32	20A	Coolant Heater

Location	Size	Description
F33	15A	Fog Light Battery Feed
F34	10A	Windshield Washer Pump Ignition Feed
NOTE: Locations marked with a (*) must use fuse only. NOTE: Descriptions marked with a (#) indicate fuses used with Eaton Hybrid-equipped vehicles.		

Power Relays

Location	Description
R1	Wiper Power Relay
R2	Wiper Speed Relay
R3	Stop Light Relay
R4	Back - Up Light Relay
R5	Ignition #1 Relay
R6	Ignition #2 Relay

Roadside Emergencies

Body Fuse / Circuit Breaker Panel

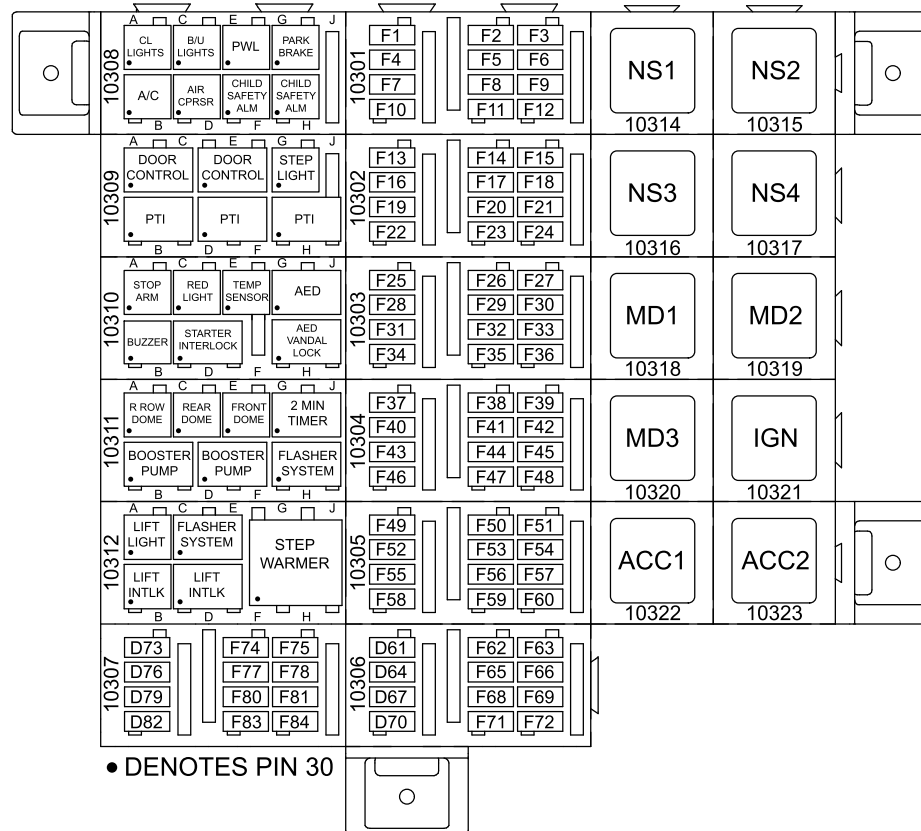

0000374186

Location	Size	Description
F1	20A	Driver's Heater
F2	20A	Stepwell Floor Heater
F3	7.5A	Convection Heater
	25A	Left Front Passenger Heater
F4	7.5A	Defog Fan Right Switch
	15A	Defog Fan (x2) Right Switch
	20A	Center Blower Right Switch
F5	25A	Left Rear Passenger Heater
F6	7.5A	Radio Power
F7	25A	Right Rear Wall Heater Switch 1 / Right Front Passenger Heater
F8	7.5A	Front Power Vent
F9	5A	Air Conditioning
F10	25A	Right Rear Wall Heater Switch 2 / Right Rear Heater
F11	7.5A	Rear Power Vent
F12	7.5A	Defog Fan Left Switch
	15A	Defog Fan (x3) Left Switch
	20A	Center Blower Left Switch
F13	25A	Step Warmer
F14	15A	Booster Pump
F15	20A	Two-Way Radio Terminal Strip
F16	3A	Air Horn

F17	15A	Dome Lights
F18	7.5A	Direct-to-Disk Recording (DDR) / Digital Video Recording (DVR) System Camera System
	20A	Video System Terminal Strip
F19	15A	Heater Mirrors
F20	15A	Air Compressor
F21	15A	Destination Sign
F22	7.5A	Traction Chains
	20A	Traction Sanders
F23	15A	Air Seat
F24	7.5A	Heated Seat
F25	15A	Dome Lights (Battery)
F26	15A	Dome Lights Option
F27	10A	Hazard Lights
F28	15A	DC Outlet
F29	15A	Fuel Fired Heater
F30	10A	Clearance Lights
F31	7.5A	Lift Interlock
F32	15A	Electric Entrance Door
	10A	Air Door Vandal Lock
	7.5A	Manual Door Vandal Lock
F33	3A	Reverse Motion Sensor

Roadside Emergencies

F34	7.5A	Luggage Box Lights
F35	5A	Radio Memory
F36	5A	Direct-to-Disk Recording (DDR) / Digital Video Recorder (DVR) System
F37	25A	Spare Tire Winch
F38	7.5A	Stop - Arm / Crossing Gate
F39	7.5A	Backup (B/U) Lights - Act By Rear Emergency Exit
F40	3A	PTI - Bus Scan / PTI - Checkmate
	10A	PTI - CRS
F41	3A	PTI - Checkmate - Deactivate
	15A	PTI - CRS - Headlights
F42	10A	Fire Suppression System
F43	3A	Starter Interlock
F44	7.5A	Alternate Entrance Door
F45	3A	Entrance Door Dump Valve
F46	3A	Fuel Fired Heater Timer
F47	3A	Stop - Arm / Crossing Gate Cancel
F48	5A	Dome Light Timer Relay
F49	7.5A	Emergency Exit Alarms
F50	7.5A	Front Cluster Light
F51	7.5A	Emergency Exit Lights
F52	3A	Traction Sanders

F53	20A	Pedestrian Lights
F54	3A	PTI - Bus Scan / PTI - Check Mate
	15A	PTI - CRS
F55	7.5A	Auxiliary (AUX) Hazard
F56	10A	Motorized Mirrors
F57	7.5A	Light Monitor
F58	10A	Step Light
F59	–	See Circuit Diagram
F60	3A	Heated Wiper Blades
F61	–	See Circuit Diagram
F62	7.5A	Strobe Light
F63	5A	Dome Light Timer Relay
F64	–	See Circuit Diagram
F65	3A	PTI - Leave No Student Behind
F66	3A	Battery Isolator
F67	–	Rear Door Options
F68	–	See Circuit Diagram
F69	–	See Circuit Diagram
F70	–	AUX Hazard
F71	3A	Locking Compartment
F72	3A	Buzzer Isolation Relay
F73	–	PTI - CRS With Enter Door Activated Dome Light / PTI - Leave No Student Behind

F74	–	See Circuit Diagram
F75	–	See Circuit Diagram
F76	–	PTI - CRS With Enter Door Activated Dome Light
F77	–	See Circuit Diagram
F78	–	See Circuit Diagram
F79	–	Dome Lights - Activated By Rear Emergency Exit
F80	–	See Circuit Diagram
F81	3A	Electrical Panel Compartment Light
F82	–	Rear Door Options
F83	7,5A	Emergency Exit Alarms (Battery)
F84	10A	AED Vandal Lock Switch

Power Relays

Location	Description
NS1	Noise Suppression Relay 1
NS2	Noise Suppression Relay 2
NS3	Noise Suppression Relay 3
NS4	Noise Suppression Relay 4
MD1	Master Disconnect Relay 1
MD2	Master Disconnect Relay 2
MD3	Master Disconnect Relay 3
IGN	Ignition Relay
ACC1	Accessory Relay 1
ACC2	Accessory Relay 2

Roadside Emergencies

Tilt Hood

Raising the Hood

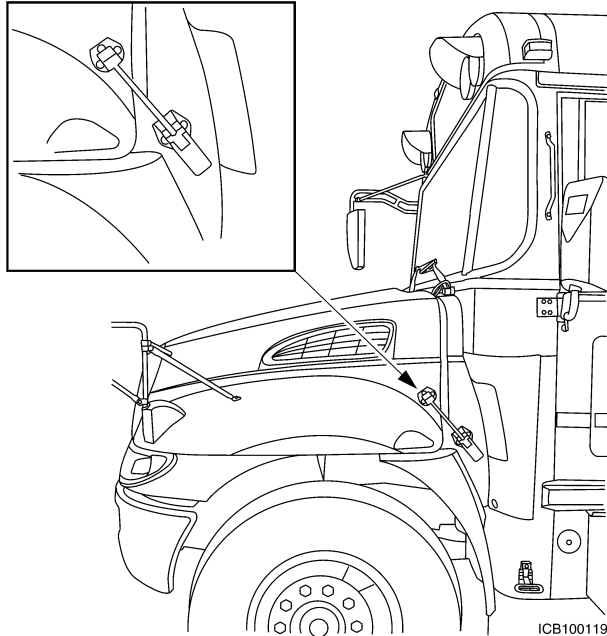

Release the latches on both sides of the cowl.

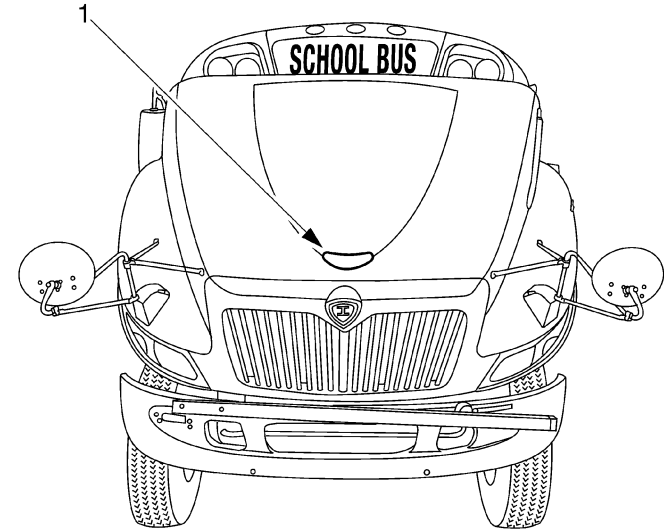

1. Grab handle

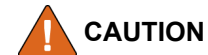

To prevent damage to property, never use the crossview mirrors as a handle. Mirror damage and misadjustment can occur.

Grab the hood handle and pull the hood forward over center and allow it to settle into the raised position.

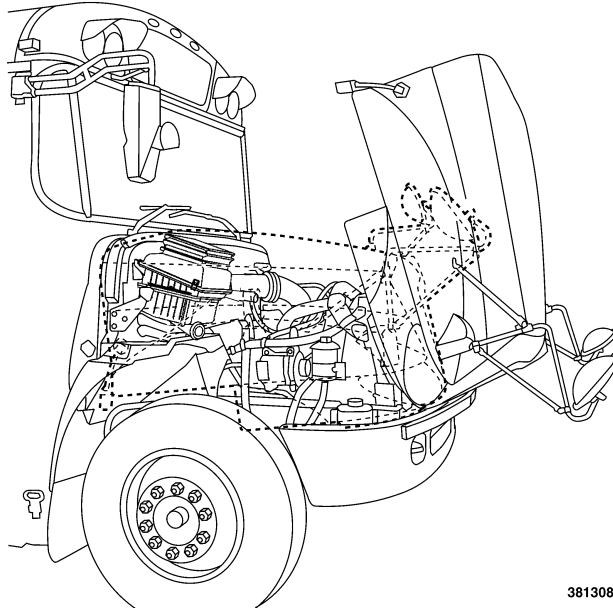

3813081

Lowering the Hood

NOTE: Ensure that the hood has no tools / parts / people in its path of motion.

1. Grab the hood handle and push the hood backward over center and allow it to settle into lowered position.
2. Engage the latches at both sides of cowl.

Emergency Starting Using Jumper Cables

WARNING

To prevent personal injury and / or death, or damage to property, the following procedures must be performed exactly as outlined; otherwise, a fire or a battery explosion could occur.

CAUTION

To prevent electronic component damage, never exceed 16.0 volts to vehicle's electrical system. When it is necessary to jump-start a vehicle, the most reliable means is to connect charged 12-volt batteries.

1. Remove metal rings or watches and do not allow metal tools to contact positive terminal of battery to prevent shorting of the electrical system.
2. Place transmission in Neutral (N) and set parking brake in both vehicles.
3. Turn OFF lights, heater, air conditioner and any other electrical loads in both vehicles.
4. Eye protection should be worn if available. If not available, shield eyes when near either vehicle's batteries.
5. Ensure the vehicle bodies or bumpers are not touching.

Roadside Emergencies

6. Connect one end of the first jumper cable to positive (+) terminal of the dead battery or (+) terminal of jump start stud and then the other end to the positive (+) terminal of the booster battery.
7. Connect one end of the second jumper cable to negative (-) terminal of the booster battery and the other end to chassis frame of the vehicle with the discharged battery. Do not attach the other end to the negative (-) battery terminal of the discharged battery, because a spark could occur and cause explosion of gases normally present around the battery.
8. Reverse above procedure when removing the jumper cables.

Towing Instructions



WARNING

To prevent personal injury and / or death, or damage to property, always install wheel chocks when manually releasing the spring brakes. For towing ensure the vehicle is securely connected to the tow vehicle and the tow vehicle parking brakes are applied before releasing the disabled vehicles parking brakes.



WARNING

To prevent personal injury and / or death, or damage to property, always use both tow hooks to prevent possible overloading and breaking of individual hooks. This vehicle may be equipped with (optional) dual tow hooks for recovery purposes only.



CAUTION

To prevent property damage, observe the following: Due to many variables that exist in towing, positioning and lifting, towing is the sole responsibility of the towing operator.

Refer to the differential and transmission equipment manufacturer for specific instructions on towing your vehicle. Further information can be located in the component owner manual that came with this truck on delivery for original sale.

Damage caused by improper towing procedures is not a warrantable failure.

Remove tow hooks from their installed position in the front of the vehicle before operating the vehicle. Failure to do so could result in the tow hooks becoming unintentionally detached from the vehicle.



CAUTION

To prevent transmission damage, vehicles should not be towed even short distances without suspending rear wheels or removing the axle shafts or propeller shaft.

In the event the chassis is equipped with tandem axles and the vehicle is to be towed from the front, the forward rear axle may be raised to clear the road surface and secured to the frame by chains or U-bolts, allowing only rear axle to contact road surface. Axle shafts must be removed from rear axle assembly. The wheel hub ends must be covered to prevent loss of axle lubricant and entrance of contaminants. Use extreme care in securing the chains or U-bolts to prevent possible damage of brake lines, hoses, or other components.



CAUTION

To prevent vehicle or engine component damage, do not use the front or rear bumper as a lift point when lifting or jacking the vehicle.

NOTE: Important factors to keep in mind when using tow hooks:

- Use both tow hooks when retrieving vehicle.
- Use a slow steady pull, do not jerk on hooks.
- Tow hooks are not designed for towing, retrieval only.

Before moving the towed vehicle, check for adequate road clearance of vehicle components. IC Bus recommends unloading the towed vehicle prior to towing to reduce any abnormal loads to the vehicle components resulting from the towing procedures. Before towing, be sure to fully release the parking brake; either Air or Hydraulic brake system.

Towing Preparation: Air Parking Brakes

The spring actuated type parking brake can be released by recharging the air system with at least 64 psi (441 kPa) of air. If brake system does not retain air pressure, then manually cage the spring brakes.

Towing Vehicle With Front Wheels Suspended

When it is necessary to tow a vehicle with the front wheels suspended, extra precautions must be taken to avoid transmission or differential damage.

Disconnect the axle shafts at the rear axle to prevent the wheels from driving the differential and the transmission. If axle shaft is not disconnected, remove the rear axle shafts from the axle assembly. Cover the wheel hub ends to prevent loss of axle lubricant and entrance of contaminants.

Towing Vehicles With Rear Wheels Suspended

Whenever possible, it is preferable to tow a disabled vehicle from the rear by raising the rear of the chassis. When towing a vehicle with the rear of the chassis suspended, the front wheels must be locked in the straight ahead position.

SECTION 11 — CLEANING



WARNING

To prevent personal injury and / or death, or damage to property, shift transmission to park or neutral, set parking brake, and install wheel chocks before performing diagnostic or service procedures.



WARNING

To prevent personal injury and / or death, or damage to property, read and adhere to all safety instructions on the labels of all cleaners. Many cleaners contain solvents that may become concentrated in the vehicle interior breathing space. While cleaning the interior area, maintain adequate ventilation by opening windows and doors.



WARNING

To prevent personal injury and / or death, or damage to property, read and adhere to all safety instructions on the labels of all cleaners. While most cleaning products are safe when used individually, certain cleaners can form hazardous gases if mixed with other cleaning products.

NOTE: Chemicals used to clean or disinfect your IC Bus® vehicle can adversely affect materials used to build the vehicle. Many common cleaning chemicals can damage or ruin the appearance of materials like ABS plastic, vinyl, rubber, aluminum, glass and painted surfaces. As with the cleaning chemicals used, the cleaning process (or the lack of a cleaning process), can also affect the life and appearance of the vehicle.

Chemicals used in premixed or aerosol disinfectant solutions can damage or affect the appearance of many interior surfaces.

The following information should be used to determine an acceptable method to clean your vehicle while maintaining the appearance and integrity of the components to be cleaned.

Surface Cleaning

General Cleaning, All Surface Types

Use a soft dry cloth on hard surfaces and a whisk broom or vacuum cleaner on flooring and upholstery to remove loose dirt and debris. Surfaces can then be washed with a damp cloth and a warm water and mild soap solution. Use a clear water damp cloth rinse to remove soap residue, then wipe dry.

Cleaning

NOTE: When using isopropyl alcohol as a disinfectant, the following precautions must be followed.

- Do not use a 70% isopropyl solution as a wash solution.
- Do not use a 70% isopropyl solution wipe on seats that are hot from daytime heat.
- Vapors can accumulate quickly when using a 70% isopropyl solution wipe. Maintain adequate ventilation by opening windows and doors.
- The effectiveness of the 70% isopropyl solution can be diminished when used in high heat conditions due to evaporation.

A 70% solution of isopropyl alcohol can be used as a disinfectant wipe. A 70% isopropyl solution is readily available from local sources.

ABS / Plastic

Plastic (ABS, Thermal Plastic, Plastic) material should only be cleaned with a warm water and mild soap solution.

Glass

NOTE: Use of abrasive cleaners can scratch or damage glass.

Use a soft cloth and glass cleaner only.

Interior

The best method to preserve the appearance and extend the life of the interior components of your IC Bus® vehicle is frequent and thorough cleaning of the components. A cleaning schedule and the cleaning requirements should be determined based on the type of service conditions in which the unit is operated.

Interior Light Bar Cleaning

All Interior Light Bars are only to be cleaned with a mild detergent and warm water. No other cleaners are to be used, as they may damage the surface.

Upholstery Care



To prevent personal injury and / or death, or damage to property, observe the following. Disinfectant products can contain solvent based chemicals that can adversely affect seat belt components.

Use a whiskbroom and vacuum cleaner to remove loose dust and dirt from upholstery and floor. Wash vinyl and woven plastic upholstery with warm water and mild soap. Wipe dry. If commercial cleaners are used, follow instructions supplied with cleaner.

Flooring

NOTE: Some buses are built with an insulating wooden sub-floor under the floor covering. Do not use a hose to clean the interior floor of the bus. Standing water may damage the wood sub-floor.

Use a damp mop with warm water and mild soap solution. Use a clear water damp mop rinse to remove soap residue. Remove any excess water remaining on the flooring after the rinse process.

Floor mounted wheelchair track should be clean of dirt, debris and cleaning solution residue when completed. Many chemicals used to maintain roads and walkways are tracked into the bus and may react with the cleaning solution. Failure to properly clean the floor track can result in track deterioration.

Exterior

NOTE: Certain cleaners contain chemicals that can damage emblems and decals. If the cleaning product label states that it should not be used on plastic parts, do not use the product to clean the unit or damage may occur that would not be covered by warranty.

The best way to preserve painted surface finish is to keep it clean by washing it often. Frequent and regular washing will lengthen the life of the vehicle's painted finish.

Wash the vehicle often with warm or cold water to remove dirt and preserve the original luster of the paint.

- Never wash the vehicle in the direct rays of the sun or when the sheet metal is hot to the touch as this may cause streaks in the finish.
- Do not use hot water, strong soaps or detergents.
- Never wipe dirt off a dry surface as the dirt will scratch the paint.

Always ensure that steps, grab handles, or any external accessories or components attached to the body exterior, are clean and free of road grime, salt, grease, ice and other debris.

To maintain optimum vehicle preservation, wash the vehicle thoroughly immediately after operating it in the presence of road salts. Many municipalities are now using magnesium chloride and calcium chloride salts in the winter time. These salts are much more corrosive than typical sodium chloride salt and must be brushed-off in addition to spraying with high-pressure water. Merely rinsing surfaces exposed to these chemicals will not remove them fully.

In addition, it is highly recommended, because of the various road chemicals used in harsh winter weather, that the under chassis and wheel ends be pressure washed during the winter and spring breaks. Adverse weather and road conditions may require more frequent washing. When exposed to heavier amounts of road chemicals, clean the vehicle as soon as possible.

Cleaning

Waxing or Polishing Vehicles

Thoroughly wash the vehicle before using any wax or polish. Use a high quality paste wax and follow the wax manufacturer's instructions to help prevent bus paint from fading.

Crossing Arm Cleaning

The crossing arm is only to be cleaned with a mild detergent and warm water. No other cleaners are to be used, as they may damage the surface.

SECTION 12 — MAINTENANCE

Preface



WARNING

To prevent personal injury and / or death, or damage to property, if the owner / operator of the vehicle is a skilled technician and intends to perform the vehicle maintenance and servicing, they are strongly urged to purchase and follow the appropriate IC Bus®, Navistar® engine or Allison Transmission service manuals or OnCommand® Service Information USB. Ordering information is included at the back of this manual.



WARNING

To prevent personal injury and / or death, or damage to property, observe the following. This vehicle has many parts dimensioned in the metric system as well as the English system. Some fasteners are metric and are very close in dimension to English fasteners in the inch system. Mismatched or incorrect fasteners can loosen and reduce clamping load, which could result in vehicle damage, personal injury or death.

NOTE: For vehicles equipped with Cummins® B engines, refer to Cummins QuickServe® Online, your Cummins Engine Operation Manual, or contact a certified Cummins repair location for specific engine maintenance intervals, capacities, and instructions.

Your bus has been engineered and manufactured to provide economical and trouble free service. However, it is the owner's responsibility to ensure the vehicle receives proper care and maintenance.

IC Bus® service parts and Navistar® engine service parts are available through your IC Bus® dealer. If IC Bus and Navistar engine service parts are not used, the owner must ensure the parts used are an equivalent.

As with any machine, take care to avoid being injured when performing maintenance, repairs or inspections. Improper or incomplete service could result in the vehicle not working properly which, in turn, may result in personal injury, damage to the vehicle or its equipment, or death. If you have any questions about performing some service, contact your nearest IC Bus® dealer or have the service done by a skilled professional technician.

Maintenance Guidelines

When servicing your bus, always:

- Turn OFF the engine unless the procedure calls for a running engine.
- Set the parking brake and install wheel chocks.

Maintenance

- Use support stands, not a jack, whenever you must be under a raised vehicle.
- Do not smoke.
- Wear safety glasses for eye protection.
- Operate the engine only in a well ventilated area.
- Do not work on brakes unless the proper precautions have been taken to avoid inhaling friction material dust.
- Do not wear loose clothing, hanging jewelry, watches or rings. Tie up hair when around rotating machinery.
- Avoid contact with hot metal parts; allow hot components to cool before working on them.
- Repair or replace any defects that were revealed during inspection, prior to operating the vehicle.



WARNING

To prevent personal injury and / or death, or damage to property, do not make modifications to any part, component, or system of the vehicle, as that can adversely affect the quality and reliability of your vehicle.



WARNING

To prevent personal injury and / or death, or damage to property, observe the following. Use only genuine IC Bus® or Navistar® engine service parts. The use of inferior parts can adversely affect the quality and reliability of your vehicle.



WARNING

To prevent personal injury and / or death, or damage to property, take care when performing any maintenance or making any checks or repairs. Some of the materials in this vehicle may also be hazardous if used, serviced, or handled improperly. If you have any questions pertaining to the service, have the work done by a trained technician.



WARNING

To prevent personal injury and / or death, or damage to property, park vehicle on hard flat surface, turn the engine OFF, set the parking brake, and install wheel chocks to prevent the vehicle from moving in either direction.



WARNING

To prevent personal injury and / or death, or damage to property, whenever disconnecting battery terminals, always disconnect ground terminal first. When reconnecting, always connect ground terminal last. Failure to follow this procedure could also result in a short to ground.

Supporting Your Vehicle for Service



WARNING

To prevent personal injury and / or death, or damage to property, always use floor stands to support the vehicle before working under it. Using only a jack could allow the vehicle to fall.

When performing service repairs on a vehicle, first:

1. Park vehicle on level concrete floor.
2. Set parking brake and install wheel chocks to prevent vehicle from moving.
3. Select jack with a rated capacity sufficient to lift and hold up the vehicle.
4. Raise vehicle with jack applied to axle(s). **DO NOT use bumper as a lifting point.**
5. Support vehicle with floor stands under axle(s).

If axle or suspension components are to be serviced, support vehicle with floor stands under frame side members.

Pre-Trip and Post-Trip Inspections

Pre-trip inspections should be performed each day by the operator before operating this vehicle. In many circumstances, a post-trip inspection can be even more valuable since it may reveal problems in time for service work to be performed prior to the next trip. This can help to minimize unwelcome surprises and unscheduled downtime. A convenient checklist of items to

include in a pre / post trip Inspection are identified in **Section 2 – Vehicle Inspection Guide** as well as Commercial Driver's License (CDL) Manuals.

Chassis Lubrication

New vehicles are lubricated at the factory. After the vehicle is placed in operation, regular lubrication and maintenance intervals, based on the type of service and road conditions, should be established. The loads carried, speed, road and weather conditions all contribute to the frequency of lubrication intervals. Thorough lubrication and maintenance at the specified intervals will insure Outstanding Life Cycle Value and will reduce overall operating expense.

In some types of operation, and where operating conditions are extremely severe (such as in deep water, mud or unusually dusty conditions), the vehicle may require relubrication after every twenty-four (24) hours of operation.

Only lubricants of superior quality, such as Fleetrite® lubricants, should be used. The use of inferior products will reduce the service life of the vehicle or result in failure of its components. IC Bus recommends the use of Fleetrite® lubricants and IC Bus® and Navistar® Engine original equipment parts.

The lubrication intervals specified should be performed at whatever interval occurs first, whether it is kilometers (miles), hours, or months.

Refer to the **Lubrication and Maintenance Intervals Chart** in the **Maintenance and Intervals section** for further details.

Engine Compartment Fluid Check Points

NOTE: Location of surge tank, power steering reservoir, washer bottle, transmission dipstick, air cleaner, oil fill tube, and oil dipstick may vary depending on model year and engine type.

NOTE: The following illustrations are for reference only and may slightly differ from the actual vehicle.

NOTE: For vehicles equipped with Cummins® B engines, refer to Cummins QuickServe® Online, your Cummins Engine Operation Manual, or contact a certified Cummins repair location for specific engine maintenance intervals, capacities, and instructions.

N9 and N10 Engine (Left-Side View)

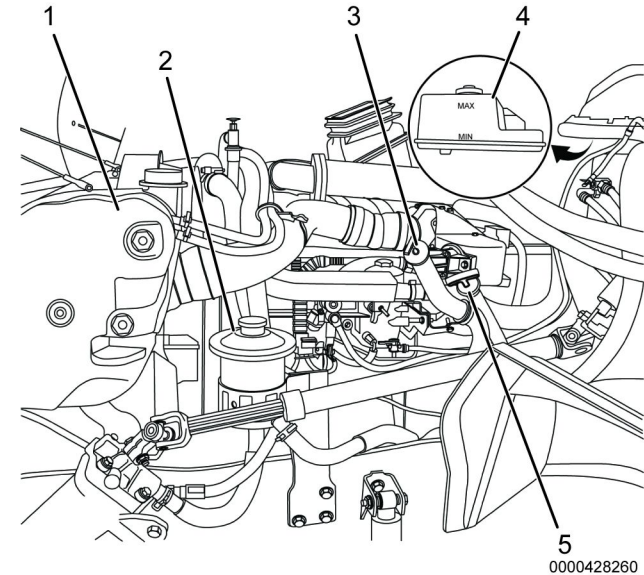

1. Engine coolant level
2. Power steering fluid level
3. Engine oil level
4. Brake fluid level (if equipped)
5. Transmission fluid level

N9 and N10 Engine (Right-Side View)

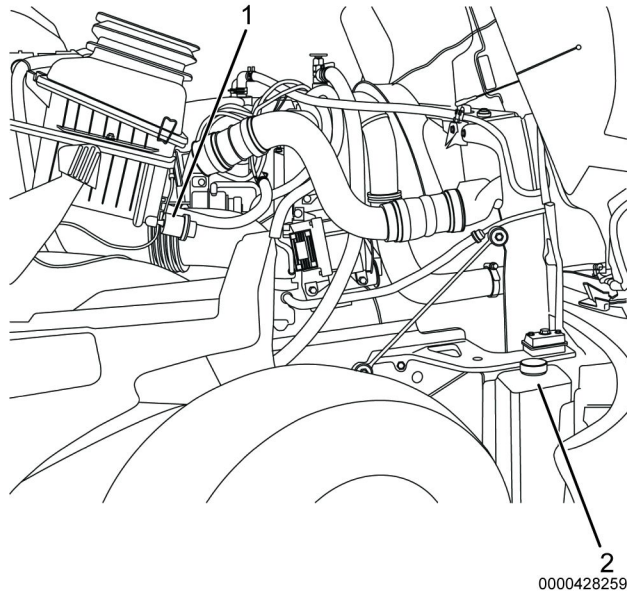

1. Air filter restriction gauge
2. Windshield washer fluid reservoir

Air-Operated Passenger Door Adjustments

The air operated door opening and closing speeds can be adjusted by the air control valve. The air valve is located behind the access panel above the entrance door. The closing force of the entrance door is determined by the adjustment of the pressure regulator. To perform these adjustments, open access panel door and use the procedures below.

Door Opening and Closing Speed Adjustment Points

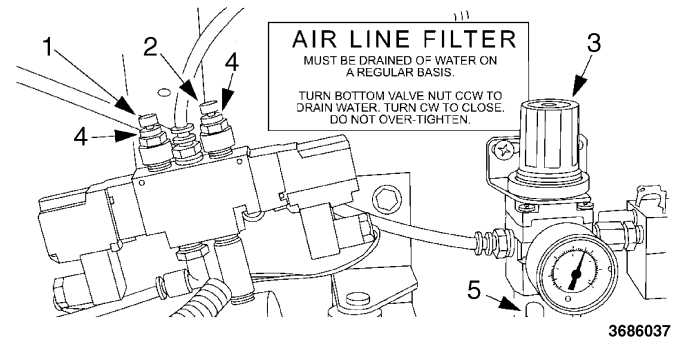

1. Opening speed screw
2. Closing speed screw
3. Pressure regulator adjustment knob
4. Locknuts
5. Air filter

Pressure Regulator Adjustment



To prevent personal injury and / or death, or damage to property, do not replace the air door regulator with one that allows pressure settings above 60 psi (414 kPa).

A properly adjusted entrance door should take approximately 4 - 5 seconds to open or close depending on the pressure and speed settings.

Maintenance

The pressure regulator should be set at approximately 40 - 50 psi (276 - 345 kPa). The regulator can only be set to a maximum of 60 psi (414 kPa). The door operates best at 40 psi (276 kPa). In cold weather, seals may stiffen and require more air pressure for proper operation. The pressure can be increased by lifting and turning the adjustment knob (3) clockwise. Then press the cap back down.

Opening Speed Adjustment

Loosen the locknut (4) and turn the opening speed screw (1) clockwise to slow the door opening speed, or counterclockwise, to increase the door opening speed. Tighten the locknut (4).

Closing Speed Adjustment

Loosen the locknut (4) and turn the closing speed screw (2) clockwise to slow the door closing speed, or counterclockwise, to increase the door closing speed. Tighten the locknut (4).

Electrically Actuated Entrance Door Adjustment

Electrically actuated doors are set to operate in 2 to 2 1/2 seconds. There is no adjustment for electrically actuated door opening and closing speed.

Axles

821280

MANUFACTURED BY IC CORPORATION			
DATE OF MANUFACTURE		5	MO. 03 YR.
GVWR	12474	KGS(27500	LBS)
GAWR FRONT	4536	KGS(10000	LBS)
GAWR REAR	7938	KGS(17500	LBS)
WITH	265/75R22.5G	TIRES	14 PLY
WITH	245/75R22.5G	TIRES	14 PLY
AT	759	KPa(110	PSI) COLD
AT	759	KPa(110	PSI) COLD
RIMS	22.5X7.50	RIMS	22.5X7.50
THIS VEHICLE CONFORMS TO ALL APPLICABLE FEDERAL MOTOR VEHICLE SAFETY STANDARDS IN EFFECT ON THE DATE OF MANUFACTURE SHOWN ABOVE.			
VEHICLE IDENTIFICATION NO.		4DRBRAAPX3A953275	
VEHICLE TYPE	SCHOOL BUS BODY# 953275MD		
452308001			

ICB100112

Typical Axle, Tire, and Rim Specifications-Vehicle Identification Label

Front Axle – Inspection and Lubrication

Check to ensure that the front axle mounting U-bolts and nuts are securely tightened.

Check front axle for damaged, binding, or worn parts, and adequate lubrication.

- Kingpin wear inspection requires that no weight is on the tires.

- Kingpin and kingpin bushing lubrication requires that the vehicle weight is off tires prior to installing grease to maximize grease distribution.
- Kingpin thrust bushing lubrication requires that the vehicle weight is resting on the tires.
- Power grease guns may be used. However, a hand-pumped grease gun should be used for optimal grease distribution within each component joint.

Refer to the **Lubrication and Maintenance Intervals Chart** and the **Lubricant and Sealer Specifications Chart** in the **Maintenance Intervals and Specifications** section for additional information.

- Inspect, lubricate, and adjust the wheel bearings at regular intervals. Refer to **Lubrication and Maintenance Interval Chart** at the end of this section for recommended service intervals. Also refer to **Lubricant and Sealer Specifications** and **Torque Specifications** in the **Maintenance Intervals and Specifications** section.

Front Axle – Normal Maintenance

During operation the air and oil inside the hub / wheel cavity expands. It is normal for a mist of oil to be present on the outside of the hubcap around the vent slit or hole. Over time, if not wiped off, this film may collect dust and appear unsightly. If the entire face and end of the hubcap become wet with oil, investigate the cause. Refer to the appropriate **Service Manual** for repair procedure.

Routinely clean the hubcap to ensure that the lube level can be easily observed through the clear window as intended.

In situations where the window is clean on the outside but discolored on the inside, check the lube level by removing the rubber fill / vent plug and insert a finger into the hole.

The specified lube level for clear window type hubcaps is from the minimum line to 5/16 in (8 mm) above the minimum line.

If the lube level suddenly drops dramatically below the minimum level, see the appropriate **Service Manual** for diagnostic procedure.

Front Axle – Alignment

Maintaining front axle alignment is very important to achieve maximum tire life and vehicle control. Inspecting steer axle tires in the first 3,000 to 10,000 service miles will generally show if tires are wearing normally.

- Rapid outside shoulder wear on both tires indicates too much toe-in.
- Rapid inside shoulder wear on both tires indicates too much toe-out.
- Excessive wear on the inside or outside of one steer tire but not the other can indicate a toe-in or toe-out condition coupled with a misaligned front or rear axle.
- Pulling to the right or left can indicate misalignment of the front or rear axle, unequal tire pressures, or a defective / mismatched tire.

Refer to the **Tires subsection** for additional related information.

Rear Axle – Inspection and Lubrication

Ensure the axle mounting U-bolt nuts, and attaching or mounting bolts and nuts are securely tightened. Loose or misaligned rear axles will affect vehicle alignment, front tire wear, and handling. Refer to **Axle U-Bolt Nut Torque Chart** in the **Maintenance Intervals and Specifications section** for torque specifications.

Check the rear axle oil level. Proper oil level minimizes gear wear, heat and damage to the wheel bearings and seals. The oil level should be at the lower edge of the level inspection hole when the vehicle is on level ground. Add oil as necessary.

Refer to the **Lubrication and Maintenance Interval Chart** and the **Lubricant and Sealer Specifications Chart** in the **Maintenance and Intervals section** for additional information.

Body

Inspect the undercoating of school buses annually and recoat as required.

Refer to **Section 2 – Vehicle Inspection Guide** and the **Lubrication and Maintenance Interval Chart** in the **Maintenance Intervals and Specifications section** for items to be inspected / serviced and recommended service intervals.

Brakes

General Information

All new IC Bus® vehicles are manufactured with non-asbestos brake linings. However, exposure to excessive amounts of brake material dust may be a health hazard.



WARNING

To prevent personal injury and / or death, or damage to property, pay strict attention to the following: if your vehicle is equipped with Automatic Traction Control or any type of locking or limited slip differential, power will be transmitted to the opposite wheel should one of the wheels slip. Both wheels must be raised free of the ground should it be necessary to operate one wheel with the vehicle stationary; otherwise, the wheel that is not raised will pull the vehicle off its support.



WARNING

To prevent personal injury and / or death, or damage to property, avoid breathing brake lining fiber dust. Always use a respirator while performing brake maintenance. Follow precautions listed below.



WARNING

To prevent personal injury and / or death, or damage to property, always check and maintain brakes in proper condition and adjustment. Out-of-adjustment brakes could cause reduced braking ability.

Follow the these precautions:

- Always wear a respirator approved by the National Institute of Occupational Safety and Health (NIOSH) or the Occupational Safety and Health Administration (OSHA) during all brake service procedures. Wear the respirator during removal of the wheels until assembly is complete.
- Never use compressed air or dry brushing to clean brake parts or assemblies.
- Clean brake parts and assemblies in the open air. During disassembly, carefully place all the parts on the floor to avoid getting dust in the air. Use an industrial vacuum cleaner with a High-Efficiency Particulate Air (HEPA) filter system to clean dust from the brake rotors / drums, backing plates, and other brake parts. After using the vacuum, remove any remaining dust with a rag soaked with water and wrung until nearly dry.
- NEVER use compressed air or dry sweeping to clean the work area. Use an industrial vacuum cleaner with a HEPA filter system and rags soaked in water and wrung until nearly dry. Carefully dispose of used rags to avoid getting dust into the air. Use an approved respirator when emptying vacuum cleaners and handling used rags.

- Wash your hands before eating, drinking or smoking. Vacuum work clothes exposed to brake dust after every use and launder them separately, without shaking them, to prevent dust from getting in the air.

Air Brakes

Brake Inspection and Adjustment



To prevent personal injury and / or death, or damage to property, always install wheel chocks when manually releasing the spring brakes, or the vehicle could roll.



To prevent personal injury and / or death, or damage to property, under no circumstances should a spring brake chamber be disassembled. Disassembly will release a powerful spring.



WARNING

To prevent personal injury and / or death, or damage to property, pay strict attention to the following. **Brake Automatic Slack Adjusters (ASA) should not need to be manually adjusted in service. ASAs should not routinely have to be adjusted to correct excessive pushrod stroke. Excessive stroke indicates that a problem exists with the foundation brake, ASA, brake actuator, other brake system components or their installation or adjustment.**

In the event that a manual adjustment must be made (although this should not be a common practice), a service appointment and full foundation brake, ASA, and other brake system component inspection must be conducted as soon as possible to ensure the integrity of the overall brake system prior to returning the vehicle to service.

IC Bus recommends that you establish a regular schedule for periodic cleaning, lubrication, adjustment and inspection of brakes, based on the type of vehicle operation. It is difficult to predetermine an exact maintenance interval (time or mileage), since vehicles are used in a variety of applications and conditions. If you are uncertain of the proper schedule and procedures for your vehicle, contact your IC Bus® dealer.

Periodically, check the push rod travel or brake adjustment. Check the push rod travel every service interval to determine if adjustment is necessary. Brake chamber push rods on original equipment chambers have a stroke indicator (an ORANGE /

RED paint marker / rib near the base of the push rod) to aid adjustment checks. If the push rod is clean and the brakes require adjustment, the ORANGE / RED marker can be seen protruding from the chamber when the brakes are applied.

Check the slack adjusters to ensure proper operation of the adjuster mechanism. Push rod travel should be at a minimum without brakes dragging.

This inspection or adjustment should only be performed by qualified service personnel and must be in accordance with instructions provided by the IC Bus® CE Service Manual.

At regular intervals, inspect the entire brake system. Check:

- Rubber components for deterioration. Replacement intervals vary according to environmental severity and time in service.
- Condition of rotors / drums, brake chambers, and slack adjusters.
- System for air leaks.
- Hose or pipes for corrosion, damage, deterioration.
- Operation of service and parking brakes.

Periodically, inspect the air brake chamber diaphragm, air compressor and air cleaner, and replace if unserviceable. Refer to **Section 2 - Vehicle Inspection Guide** as well as the **Lubrication and Maintenance Intervals Chart** in the **Maintenance Intervals and Specifications section**.

Inspect brake lining at every maintenance interval. When brake lining or blocks are worn to within 1/16 in (1.6 mm) of the rivets, replace the brake lining.

Air Dryer

The function of the air dryer is to collect and remove moisture and contaminants before the compressed air reaches the air reservoirs. This protects the air system components from malfunctioning including blockage, corrosion, and freezing. For air tank draining requirements, refer to the **Maintenance Instructions section** as well as local regulations.

The air dryer is installed in the discharge line between the air compressor and the air system reservoirs. The air dryer includes a replaceable desiccant cartridge and oil blocking filter that is periodically serviced. It also may include a heater to prevent the discharge valve from freezing in cold weather.

Air Dryer Desiccant Replacement

Open reservoir drain valves and check for presence of water. Small amounts of water due to condensation is normal. If the wet (air) tank and primary or secondary tanks are collecting an abnormally high amount of water between regular air tank drain intervals, replace the air dryer desiccant.

The air dryer desiccant replacement interval may vary; it is generally recommended that the desiccant be replaced every 12 months for small air dryers like the Bendix AD-IP[®], or every 24 months for large air dryers like the Bendix AD-9[®]. If experience has shown that extended or shortened life has resulted for a particular installation, then the interval should be increased or reduced accordingly.

Maintenance

Air Dryer Purge Valve

Check that the purge valve opens and expels moisture when the air governor shuts off the air compressor. Air should escape rapidly and then quickly stop. If the purge valve does not open, or you can hear a slight audible air leakage past the valve for longer than 30 seconds, the valve may be sticking and should be rebuilt. Purge valves may also stick if the air dryer heater has failed and ice is clogging the valve.

Air Dryer Heater

Check that the air dryer heater activates at temperatures below freezing. With the vehicle in a cold environment and before the engine is started, turn ON the ignition and touch the air dryer

housing. It should be warmer than other metallic items on the vehicle. If some warmth cannot be felt it, may indicate that the heater element or the wiring powering should be serviced.

Air Reservoir / Tanks Moisture Draining

Moisture taken in with the air through the compressor inlet valves collects in the reservoirs. Drain the wet tank reservoir every day at the end of the trip. Drain the primary and secondary tanks periodically. Open the drain cock located either on the bottom of the tank or in the end of the tank. For ease of draining, some or all tanks may be equipped with optional pull cords. There must be some air pressure in the system to ensure proper drainage. Close the drain cocks after all moisture has been expelled. If you are unsure which tank is the wet tank, drain all tanks daily.

On vehicles equipped with automatic drain valve(s), moisture and contaminants are automatically removed from the reservoir to which it is connected. It operates automatically and requires no manual assistance or control lines from other sources. Periodically, manually drain the reservoir and ensure the drain passage is not plugged.

Some vehicles are equipped with remote air piloted drain valves. These are actuated (drained) using dedicated individual controls from the driver's control panel.

SmartTrac™ Hydraulic Brakes (If Equipped)

Brake Inspection and Adjustment

This inspection or adjustment should only be performed by qualified service personnel and must be in accordance with instructions provided by the **IC Bus® CE Bus Service Manual**.

Establish a regular schedule for periodic cleaning, lubrication, and inspection, based on the type of vehicle operation. It is difficult to predetermine an exact maintenance interval (time or mileage) since vehicles are used in a variety of applications and conditions. Refer to the **Lubrication and Maintenance Interval Chart** in the **Maintenance Interval and Specifications** section for recommendations.

On a periodic basis of at least once per year inspect the entire brake system for:

- The proper operation of the service and parking brakes.
- The condition of the discs, calipers, and ABS exciter teeth.
- Hydraulic fluid leaks.

- Hose or pipe damage.
- The condition of the ABS wheel speed sensors and wiring.
- Proper ABS wheel speed sensor-to-exciter teeth gap.

Inspect brake lining at every maintenance interval. During severe service operations or prolonged periods of stop-and-go operation, the brakes may require more frequent inspection. Establish inspection intervals that provide for lining replacement before damage to the disc occurs. Excessive lining wear may allow the metal brake shoe to damage the brake disc.

Fluid Precautions

Use only DOT 3 or DOT 4 Brake Fluid that is properly identified in a sealed container. Avoid brake fluid contact with painted surfaces. It will damage the paint.

Brake Lines, Hoses, and Fittings

- Check lines for kinks, dents, corrosion, or ruptures.
- Check hoses for abrasion, kinks, soft spots, ruptures, collapse, cracks, twists or loose frame supports. When replacing a hose, be sure there is enough clearance to prevent the new hose from rubbing against other components.
- Examine all connections for leaks.
- Repair or replace brake line tubes, hoses or fittings as required.

Maintenance

Hydraulic Brakes

Brake Fluid Level (SmartTrac™ System)

NOTE: If brake fluid is added frequently to maintain the proper level in the master cylinder, it means that there is either rapid pad wear or a fluid system leak. A more frequent and thorough brake inspection is required.

Do not fill the master cylinder to the top of the reservoir. Overfilling may lead to overflow. A MIN and MAX indicator are located on the reservoir; do not exceed the MAX line with brake fluid.

Check and refill the brake fluid reservoir using the following procedure:

1. Clean the reservoir caps before removal to prevent dirt or water from entering the reservoir.
2. Visually inspect the fluid level.
3. If necessary, add brake fluid from a clean unopened container.
4. Use only DOT 3 or DOT 4 brake fluid certified to meet manufacturer specifications.

5. Fill the brake fluid reservoir to the MAX line, but do not exceed the MAX fill specifications.

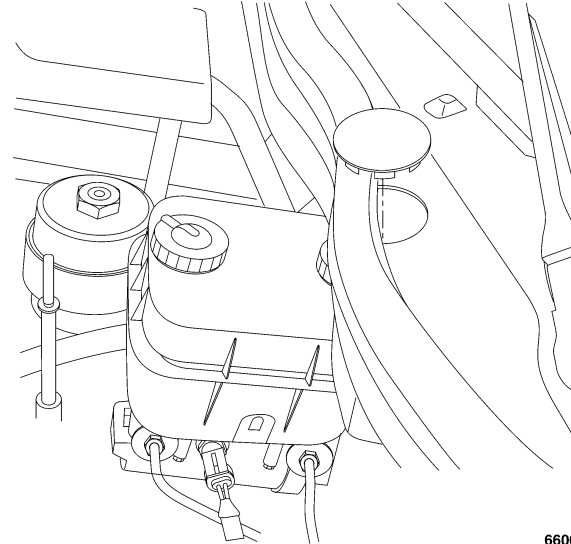

6600023

SmartTrac™ Hydraulic Brakes - Fluid Precautions

The SmartTrac™ brake system consists of two completely separate hydraulic systems operating with two different and incompatible fluids: power steering fluid and hydraulic brake fluid. Failure to observe precautions preventing the contamination of either system with fluid from the other will result in swelling and deterioration of rubber parts leading to reduced brake performance and eventual brake failure.

NOTE: Use only DOT 3 or DOT 4 Brake Fluid that is properly identified in a sealed container. Avoid brake fluid contact with painted surfaces. It will damage the paint.

The following should always be observed to avoid fluid contamination. Use only properly identified and specified (or equivalent) fluids, and add fluids only to the following locations:

- Brake fluid to the brake master cylinder
- Power steering fluid to the power steering fluid pump reservoir

Driveline Parking Brake



WARNING

To prevent personal injury and / or death, or damage to property, when servicing the vehicle, park on a flat level surface, set the parking brake, turn off the engine, and install wheel chocks.



WARNING

To prevent personal injury and / or death, or damage to property, operate vehicle in area with sufficient space to safely perform Parking Brake Burnishing Procedure.

Parking Brake Burnish Procedure

1. Accelerate the vehicle to 10 mph (16 km/h).
2. Shift the transmission to Neutral (N).
3. Using the parking brake foot pedal, bring the vehicle to a gradual and complete stop using only the parking brake.
4. Repeat the above steps nine times at two-mile intervals.

Parking brake adjustment should only be performed by qualified service personnel, and in accordance with instructions provided in the IC Bus® Service Manual.

Chassis Inspection

Regular maintenance and replacement of worn, loose, or damaged parts will usually prevent more serious problems from developing later.

The lubrication and maintenance intervals present a good opportunity to inspect the vehicle. Refer to the **Lubrication and Maintenance Intervals Chart** in the **Maintenance Intervals and Specifications section** for detailed information on specific chassis items to inspect.

Electrical

Alternator–Starter–Battery Test

An Amps-Volts-Resistance test should be performed periodically by a trained professional. The test checks for alternator amperage output, starter current draw, and battery amperage capacity. This type of testing detects weaknesses that may not yet be apparent during normal daily operations.

Terminal Inspection–Cleaning–Corrosion Protection

Periodically, inspect electrical connectors in the battery box, electrical panel box and engine compartment for corrosion and tightness. Clean all exposed terminals and apply a lubricant sealing grease such as Fleetrite® 472141–C1 or equivalent. The inspection / cleaning / corrosion protection should include feed through connections, power and ground cable connections for batteries, engines and the starter stud.

Inspect exposed cables for fraying or signs of abrasion.

Connectors that are more subject to corrosion may be disassembled and sprayed with a light coating of dielectric grease. Use grease sparingly. Too much grease will not allow air to escape from the connection and this compressed air will push the connection apart.

Accessory Feed Connections



To prevent personal injury and / or death, or damage to property, do not increase size of fuse or circuit breaker or change type of breaker supplied with your truck, as this could cause wiring to overheat and possibly burn. Electrical circuits are designed with a particular wire gauge to meet the fuse and circuit breaker current rating.

Vehicle electrical systems are complex and often include electronic components such as engine and transmission controls, instrument panels, antilock brakes, etc. While most systems still operate on battery voltage (12 volts), some systems can be as high as 90 volts or as low as 5 volts. Refer to the **Electrical Circuit Diagram Manuals** available from IC Bus to ensure that any additional body lights and accessories are connected to circuits that are both appropriate and not overloaded. No modification should be made to any vehicle control system without first contacting your IC Bus dealer.

Engine

General

The vehicle (engine) owner is responsible for the performance of all scheduled maintenance. The required maintenance operations may be performed by the owner or at a service establishment of the owners choosing. Any replacement parts used for required maintenance services or repairs should be genuine IC Bus or Navistar engine service parts. Use of inferior replacement parts may hinder operation of engine and emission controls and can reduce engine life and / or jeopardize the warranty.

Keep the receipts covering the performance of regular maintenance in case questions arise concerning maintenance. The receipts should be transferred to each subsequent owner of the vehicle (engine).



CAUTION

To prevent damage to the Engine Control Module it should never be directly spray-washed. Failure to heed this caution may result in vehicle and / or engine component damage.

NOTE: For vehicles equipped with Cummins® B engines, refer to Cummins QuickServe® Online, your Cummins Engine Operation Manual, or contact a certified Cummins repair location for specific engine maintenance intervals, capacities, and instructions.

NOTE: For complete operation and maintenance information pertaining to your engine refer to the Engine Operation and Maintenance Manual provided with the vehicle.

For effective emission control and low operating cost, perform the maintenance operations listed on the following pages. It is recommended to perform the operations at the specified periods or mileage intervals indicated (miles, kilometers, hours, or months) in the **Engine Operation and Maintenance Manual**.

Service intervals are based upon average operating conditions. In certain environments and duty cycles, more frequent servicing may be required.

Engine Fluids and Contaminated Material



GOVERNMENT REGULATION: Engine fluids (oil, fuel, and coolant) may be a hazard to human health and the environment. Handle all fluids and other contaminated materials (such as filters, and rags) in accordance with applicable regulations. Recycle or dispose of engine fluids, filters, and other contaminated materials according to applicable regulations.

Maintenance

Scheduled Maintenance

For information regarding routine scheduled maintenance such as replacement of oil, filters, coolant, belts, belt tensioners, etc, and inspection and adjustment of items such as valve lash, etc. refer to the **Engine Operation and Maintenance Manual** supplied with the vehicle.

NOTE: For vehicles equipped with Cummins® B engines, refer to Cummins QuickServe® Online, your Cummins Engine Operation Manual, or contact a certified Cummins repair location for specific engine maintenance intervals, capacities, and instructions.

Air Induction System



WARNING

To prevent personal injury and / or death, or damage to property, when performing maintenance and repairs to any turbocharged engine with engine air inlet piping disconnected, a turbocharger compressor air inlet protective shield should be installed over the turbocharger air inlet. Order the protective shield for engines from your local IC Bus® dealer.

Perform a complete inspection of the air induction system. Disassemble the joints of each aluminum component and

inspect for salt build up and chlorine that can cause aluminum particles to flake off and enter the engine combustion chambers.

If corrosion is present (usually appears at the pipe connections), use a wire brush to clean the inside of the pipes and inside the rubber hoses. Clean all components thoroughly before reassembly.

If the intake pipes are pitted at the joint ends, Room Temperature Vulcanizing (RTV) silicone may be used to seal the joints. Ensure that no excess sealant is on the inside of the pipe that can be pulled into the engine. If the service condition of the pipes, hoses, or clamps is questionable, replace them.

- Check for loose hoses and clamps.
- Check for ruptured or collapsed hoses.
- Check air cleaner housing for cracks.

Air Cleaner Element Service

NOTE: Do not change the air cleaner element configuration from the factory installed configuration. If equipped with a single element or dual element that configuration must stay with the vehicle. Failure to comply may affect engine performance.

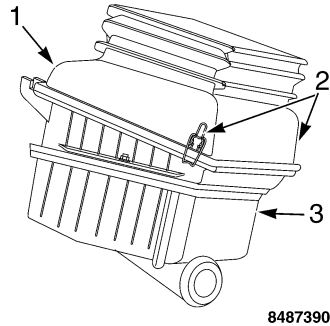

1. Inlet lid
2. Hold-down latch
3. Air cleaner housing

NOTE: Be careful not to bump the air filter element while it is in the housing; this can raise a cloud of dust that can enter the clean side of the piping to the turbocharger.

1. Unhook the hold-down latches and remove the inlet lid from air cleaner housing. Remove the filter element carefully and slowly, then discard the old element.

2. Wipe the inside of the air cleaner housing with a clean, damp cloth. Be sure to clean the gasket sealing surface. Be sure to wipe out any dust that has fallen into the port to the turbocharger. **DO NOT** use compressed air for this cleaning!
3. Visually inspect the air cleaner housing for damage or distortion, which could allow unfiltered air to enter the engine. Inspect to be sure that the rubber dust unloader valve at bottom of housing is in place, free of debris, and not cracked.
4. Inspect the new air filter element for a damaged or nonresilient rubber gasket. Inspect the air filter element body for dents or excessive pleat bunching. If any of the mentioned conditions exist, obtain and install an alternate new air filter element from your International dealer.

Maintenance

- Carefully install the new air filter element into the air cleaner housing.
- Seat and install the inlet lid squarely onto air cleaner housing, hook and latch inlet lid to air cleaner housing with hold-down latches.
- When servicing is completed, reset air restriction gauge by pushing and holding the reset button and releasing it. The YELLOW indicator will drop below the window. The air restriction gauge is now ready for the next operating cycle.

Air Restriction Gauge Service

The initial restriction with a new air filter element will vary with air cleaner design and installation.

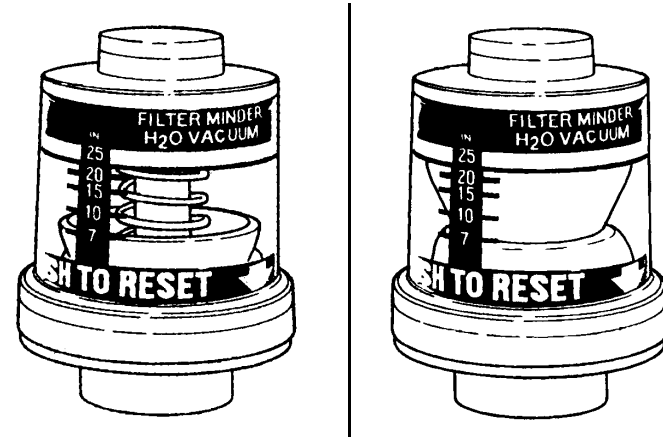

Troubleshooting

No Restriction Reading

Possible Causes	How To Check
Plugged fitting or vacuum line	Apply vacuum to gauge until locked up at RED zone. Reconnect line and hold in reset button. Indicator will fully return unless line or fitting is plugged. A slow return is normal due to safety filter in fitting.
Leak in vacuum line	Apply vacuum to gauge until locked up at red zone. Reconnect gauge and close end of line airtight. Hold in reset button. Indicator will drop slightly and then not move unless vacuum line has a leak.
Leak in gauge	Repeat above except close gauge connection airtight.
Engine air flow too low to generate a restriction reading after being reset	Rev engine from idle to full RPM multiple times to increase air flow enough to create an initial reading.
Air cleaner element split open	Visually inspect element.

High Restriction Reading

Possible Causes	Explanation
Plugged elements	Ultra fine particles are difficult to remove and cleaning may not sufficiently lower restriction.
Plugged inner element (if equipped)	Replace inner element.
Plugged inlet screens or ducts	Check system upstream from restriction tap for debris, damage, or improper installation.
Heavy snow or rain	Temporary high restriction can occur during a rain or snow storm and it disappears after drying out. cold air may be so dense that high restriction may not reduce engine power before elements are damaged from high vacuum. If gauge is locked up at red zone check elements for damage.

Chassis-Mounted Charge Air Cooler and Radiator Core Inspection and Cleaning

With the engine OFF, visually inspect the charge air cooler core and radiator core assembly for debris and clogging of external fins. Prior to engine operation, remove any debris blocking the core.

Cooling System



WARNING

To prevent personal injury and / or death, or damage to property, do the following when removing radiator or deaeration cap:

- Allow engine to cool for 15 minutes or more.
- Wrap a thick cloth around radiator cap or deaeration cap.
- Loosen cap slowly a quarter to half turn counterclockwise to vent pressure.
- Continue to turn cap counterclockwise to remove.



WARNING

To prevent personal injury and / or death, or damage to property, do not exceed the pressure rating on the deaeration tank cap. Ensure that the pressure rating of the deaeration tank cap matches that listed on the side of the tank, or the tank may burst.



CAUTION

To prevent vehicle and / or engine component damage, observe the following. If the coolant should get extremely low and the engine very hot, let the engine cool for approximately 15 minutes before adding coolant; then, with the engine running, slowly add coolant. Adding cold coolant to a hot engine may crack the cylinder head or cylinder block. Never use water alone.

Ensure that coolant level is maintained between the COLD MIN and COLD MAX lines on the deaeration tank when engine is cold.

Gravity-Fill Coolant Method

Filling Instructions

NOTE: If system has been drained, fill with fresh 50/50 diluted concentrate coolant or 50/50 premixed coolant. If the system has been flushed with water, a significant amount of the freshwater flush will remain in the system. In this case, refilling with a mixture with a higher percentage (75%) of coolant concentrate is advised in order to achieve a final mixture close to 50/50.

NOTE: Using the KL5007NAV coolant management tool is the recommended procedure for filling the cooling system.. However, in some cases this tool may not be available, and the following gravity-fill procedure may be used instead. Contact an International dealer for special instructions on filling the coolant system.

NOTE: This is a traditional gravity-fill-only method that involves pouring or pumping the coolant into the deaeration tank of the cooling system and using a combination of gravity and engine operation to purge the system of air. Depending upon your engine configuration, this method may include the disadvantage of a requirement to temporarily disconnect the Exhaust Gas Recirculation (EGR) wiring harness to protect the EGR from heat damage prior to being completely deaerated (freed of trapped air). This process may generate a fault code that might require further investigation by an authorized International dealer.

For vehicles with N9 and N10 engines, see the following instructions on filling the cooling system.

1. Open any shutoff valve in heater circuit, in-transit heat circuit, or Auxiliary Power Unit (APU) circuit (not shown).
2. Open cooling system vent valve (where applicable) on top radiator pipe.
3. Fill deaeration tank with proper coolant to top of fill neck.

4. Close cooling system vent valve when air is purged and coolant is seen flowing from valve (where applicable).
5. Disconnect EGR valve electrical connector. For N9 and N10 engine EGR location see N9 and N10 engine left-side view.

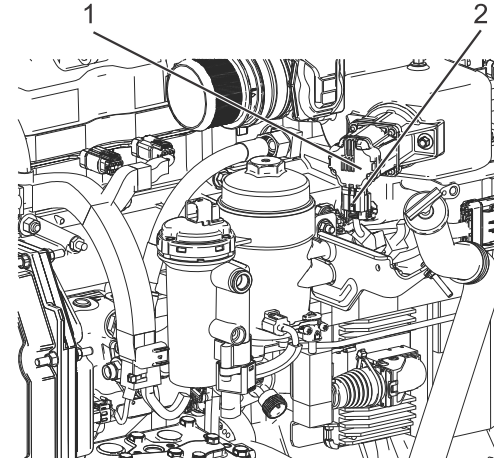

0000038374

N9 and N10 engine left-side view

1. EGR valve
2. EGR electrical connector

Maintenance

6. To purge air from cooling system, start engine and run at an elevated idle (1,500 rpm) for approximately 10 minutes. Do not exceed 220°F (104°C).
7. Verify coolant concentration and adjust coolant level to MAX level.
8. Install deaeration tank cap (not shown) once coolant is stabilized at MAX level.
9. Turn OFF engine and connect EGR valve electrical connector.
10. Verify coolant is at correct level and concentration.
11. Clear fault code that was set when EGR valve was disconnected (consult IC Bus® dealer).
12. Inspect and adjust coolant level as necessary, prior to daily operation.

For vehicles with Cummins® B engines, see the following instructions on filling the cooling system.

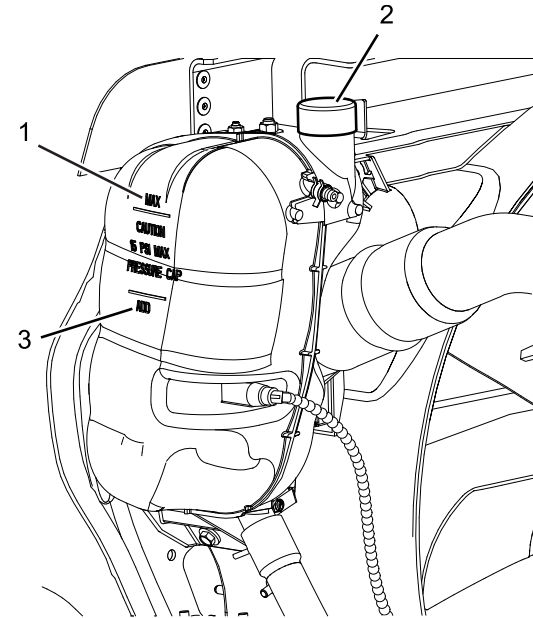

0000055766

Typical Deaeration Tank for Cummins B Engine. (tanks may vary)

1. COLD MAX lines
2. Vented fill cap
3. COLD MIN (ADD) line

To function properly, the coolant system must be completely filled with coolant and all air must be expelled. To accomplish this, the following procedures should be carefully completed:

1. Open the Heater Core Supply cutoff valve (page 123) .
2. Close the Heater Core Return cutoff valve (page 123).
3. Open the Heater Core Return Bleed Valve.
4. Fill the system to top of the fill neck in the Deaeration tank. Use a 50/50 mixture (75/25 if it has been flushed with water) of the proper coolant concentrate (refer to **Lubricant and Sealer Specifications** in section **Maintenance Intervals and Specifications**) and demineralized or distilled water into the deaeration tank. A 50/50 coolant mixture will achieve a -34°F (-37°C) freeze point. The first pour should reach to the top of the reservoir fill neck.
5. Turn on engine and operate at low idle.
6. Maintain coolant level above the add line as the bottle level draws down.
7. Increase engine speed to 1,000 rpm.
8. Continue to operate the engine at 1,000 rpm and maintain bottle level above the add line until the heater core return bleed valve begins to purge fluid.
9. Return engine to low idle.
10. Close the heater core return bleed valve.
11. Open the heater core return shutoff valve.
12. Raise engine speed to high idle until coolant temperature reaches 190°F (88°C).
13. Continue operating engine for an additional five (5) minutes after coolant temperature reaches 190°F (88°C).
14. Return engine to low idle, allow engine to cool and shut down.
15. Top off coolant level to COOLANT MAX line (1) on the deaeration tank.
16. Install pressure cap.
17. Let engine completely cool. Recheck coolant level and concentration / freeze point with a refractometer and top off as needed to achieve a coolant level at the COLD MAX line when cold.

Coolant and Optional Coolant Filter

IC Bus recommends using only approved coolant with 2010 cooling packages, and will not warrant cooling systems that have not utilized the recommended coolant.

The label on the deaeration tank provides additional coolant / antifreeze information. Consult the **Engine Operation and Maintenance Manual** for coolant service life details.

Some engines are ordered with an optional coolant filter that should be replaced periodically.

Maintenance

For Ultra ELC equipped vehicles use only water filters without Supplemental Coolant Additives (SCAs) as SCAs are not necessary with Ultra ELC. Any time a silicone gasket / seal exposed to the coolant is replaced while using Ultra ELC, a fresh charge of silicates must be added to the coolant to protect the new gasket / seal.

IC Bus recommends Ultra ELC due to its ease of maintenance and lower long-term cost of operation. Any system using or contaminated with more than 10% conventional coolant must be maintained like conventional coolant and receive regular tests for Supplemental Coolant Additive (SCA) levels.

Coolant Concentration / Freeze Point



CAUTION

To prevent vehicle and or engine component damage, always use the specified coolant to top-off the cooling systems. Failure to do so may result in the loss of extended life properties. Should top-off occur with conventional coolant(s) exceeding 10% of the total cooling system capacity, drain and refill with the proper coolant.

Check the cooling systems twice a year to ensure proper coolant / water concentrations. A 50/50 mixture created in the shop using coolant concentrate and water, Shell Rotella® ELC pre-Mixed coolant (RED) or Fleetrite® NOAT ELC premixed coolant (RED) and will provide freeze protection down to 34°F (-37°C) if no further dilution is experienced during installation.

Concentrations more than 67% are not recommended. The use of ELC pre-mix to make up for coolant loss will conveniently ensure the glycol / water concentrations stay in balance.

Fan Clutch

Inspect for proper operation, secure electrical connections, or air supply as appropriate. See the IC Bus® CE Bus Service Manual for details.

Heater and Coolant Hose Inspection and Replacement Guide

Proper maintenance and inspection of the heater and coolant distribution system is required to maximize hose life, maintain performance of the system, and avoid potential failures.

Poorly maintained coolant is cause for hose failure. Coolant level and condition should be inspected on a regular basis.

- Check coolant level as part of the daily inspection.
- Check coolant concentration per coolant manufacturer requirements.

Heater and coolant hose inspections should be performed on an annual basis, or anytime a hose repair is made. To properly inspect engine and body heater hoses, protective metal or plastic covers and closeout panels are to be removed to allow inspection of the complete heater and coolant / hose system.

Once protective covers and closeout panels are removed, the following basic steps should be followed.

- Perform a visual and touch inspection of all hoses. Hose inspection process is to include all engine compartment and body, interior and under body, hoses.
- Check heater and coolant system for signs of cold and hot leaks.
- Pay attention to the hose ends and contact points that will typically show early signs of hose failure. Observe the area around all hoses for signs of leakage.
- Synthetic rubber can oxidize and harden over time. Squeeze the hose to ensure it is pliable. Entire hose length should have a consistent feel and appearance.
- Many times hoses will fail from the inside. A hose that looks to be in good condition can fail due to deterioration of the inner hose and reinforcement. This type of deterioration can sometimes be detected during pressure testing.
- Cracks, blisters, or splits in the hose outer cover are the most visible signs of hose failure.
- Pressure test complete heater and cooling system annually. Test should be completed while performing hose inspection to allow all hoses to be observed for bulges and leaks.

Upon completion of the inspection process, reinstall all protective covers and closeout panels to original condition.

Many factors influence hose life such as location, years in service and service environment. Heater and coolant hose replacement is recommended after 5 years of service. In the event a hose failure is experienced prior to the recommended replacement time frame, age and condition of remaining hoses should be considered to determine if all engine and body hoses should be replaced to reduce the potential for additional failures.

Frame and Optional Tow Hooks

The Bus Chassis are manufactured with frame rails of High Strength Low Alloy (HSLA) steel and must be handled in a specific manner to ensure maximum service life. Specific instructions are published concerning proper repair of frame rails. Before attempting frame repair or modification, consult the service manager of your IC Bus® dealer.

Inspect front and rear tow hooks for damage or loose mountings.

Fuel System



GOVERNMENT REGULATION: Diesel fuel sold for use in 2007 and later highway vehicles must be limited to a sulfur content of 15 parts per million (ppm).



WARNING

To prevent personal injury and / or death, or damage to property, never overfill the fuel tank. Overfilling the tank could cause fuel spillage and / or increased pressure inside the fuel tank. Pressure in an overfilled tank may cause leakage in the fuel system, which could result in a potential fire / explosive hazard.

Frequently inspect condition of fuel tanks and mounting hardware, fuel tank cap and vent, fuel lines, clips and routing. Periodically drain water and sediment from the bottom of the fuel tank via the drain plug on the bottom of the fuel tank.

See the **Engine Operation and Maintenance Manual** service intervals for fuel filter water trap draining, fuel strainer draining and fuel filter replacement.

Fuel Tank Draining and Cleaning

Periodically (annually is recommended) drain water and sediment from the fuel tank via the drain plug on the bottom of

the fuel tank. Drain and flush sediment from fuel tank at least every 12 months or more frequently if fuel quality or type of fuel dictates.

Since Ultra-Low Sulfur Diesel (ULSD) fuel tends to absorb more water and engines are operating at higher temperatures, microbe growth in the fuel tanks has become more prevalent. Microbe growth results in more contaminants in the fuel and reduces fuel filter life. Since fuel tank draining does not remove all microbes, fuel tank draining alone will not eliminate the problem. For vehicle operators experiencing microbe growth in their fuel, the following is recommended:

1. Drain and clean the fuel tank(s) every 12 months or more often. Clean the tanks with a professional fuel tank cleaning system (available through your IC Bus® dealer) or have your local IC Bus® dealer perform the service for you.
2. Treat your vehicle fuel tanks and bulk tanks regularly with a biocide from a reputable vendor.
3. Purchase fuel only from vendors which you know pretreat their fuel with biocides.
4. Periodically, test the fuel supplied by your fuel vendor for the presence of microbes.

Heater System

Check all heating / cooling fans for operation. Ensure heater cut-off valves are opened / closed during appropriate cold / warm months for greatest passenger comfort. Maintain heat exchanger air filters (if equipped). The driver-side 's heater filter is located behind the grill near the floor, to the left of the driver's seat. The optional step well heater filter is located behind the grill to the front of the step well. Under seat heaters may have an optional filter on the top surface of each heater box.

Heater booster pumps should not be run dry for more than 30 seconds. This may cause the seals to fail.

Integrated Air Conditioning (IC Air) System

The following conditions require the immediate attention of your nearest authorized IC Air Service Center.

- Vibration and / or noise from engine compartment
- Oil around refrigeration hose connections
- Water dripping from evaporator and / or air ducts
- Vibration and / or noise from the evaporator area
- Noticeable decrease in system performance
- Reduced air flow (this condition is normally a result of dirty or clogged evaporator filters).

Noise Emissions – Maintenance, Use and Repair

Instructions for Proper Maintenance

In order to comply with federal exterior noise regulations, your vehicle may be equipped with noise emission items that must be properly maintained, used, and repaired. Depending upon the vehicle configuration, it may incorporate all or some of the following:

Air Intake System

- **Air Cleaner** – should be inspected and its location should not be altered. Do not alter inlet and outlet piping.

Body

- **Wheel Well** – splash shields, cab shields, and underhood insulation should be inspected for deterioration, dislocation, and orientation and repaired or replaced as necessary.

Cooling System

- Check fan for damage to blades. Replace, if damaged, with manufacturer's recommended parts. Inspect for fan-to-shroud interference and any damage to shroud, such as cracks and holes.
- Fan speed ratio should not be changed and fan spacer dimensions and position should not be altered.

Maintenance

- Inspect for proper operation of fan clutch, making sure that the fan is disengaged when cooling of engine is not required.

Engine Noise Shields / Blankets

- Engine valve covers, oil pans, and block covers are made to damp out engine mechanical noise and, if needed, should be replaced with original equipment parts.

Exhaust System

- Inspect for leaks at various joint connections and tighten clamps. Make visual inspection for cracks or holes in muffler and tailpipe. Always replace with manufacturer's recommended parts. Tailpipe elbow or offset tailpipe orientation must not be changed from standard position as originally received.
- To prevent abnormal changes in vehicle sound level, it is necessary for the owner to perform inspections and necessary maintenance at the intervals shown in the maintenance schedules, and record them on the maintenance record maintenance record form provided.

Maintenance

Drive Shaft

At the regular lubrication interval, check universal joints, slip joint, slip joint boot, and carrier bearings for any evidence of wear or looseness.

Suspension (Air and Steel Springs)



CAUTION

To prevent vehicle and / or engine component damage, do not adjust air suspension height to any setting other than the specified setting. Altering the height setting will change the driveline angle and may result in unwarrantable component damage, such as transmission component damage.

Periodically verify driveline axle air suspension height and height control valve performance. Refer to the **Lubrication and Maintenance Intervals Chart** in the **Maintenance Intervals and Specifications** section.

Periodically:

- Check condition of spring leaves for evidence of fatigue, bending or breakage.
- Check condition of suspension mounting brackets and bushings.
- Check that torque rod mounting fasteners are tight.

NOTE: When retorque is required, ensure the part is in like new condition. If it can't be retorqued, then the part needs to be replaced.

Suspension alignment must be maintained at all times.

Check the U-bolts as follows:

- After the bus has been operating under load for 1,000 miles (1,600 km), retorque the U-bolt nuts.
- Thereafter, retorque the U-bolt nuts every 36,000 miles (58,000 km).
- Clean and lubricate the U-bolt, nut threads, and seats to ensure a like new condition when retorquing.

Steering

General



WARNING

To prevent personal injury and / or death, or damage to property, always follow recommended procedures for steering system maintenance. Failure to maintain the steering system in proper condition can cause reduced steering ability.

NOTE: Steering problems must be corrected at once by a qualified mechanic.

Inspect the steering system:

- Check tie rod ends, drag link ends and kingpins. Joints and fasteners must be tight. Articulating joints must be well lubricated.
- Check for installation and spread of cotter pins and tightness of nuts at both ends of tie rod and drag link.
- Check that pitman arm (steering arm at steering gear) mounting is tight and locked. Check the power steering system for leaks or hose chafing. Repair at once.
- Maintain proper power steering fluid level.
- Regularly inspect steering column joint bolts and steering linkage, particularly for body-to-chassis clearance.

Tightening Steering Intermediate Shaft Joint Bolts

Check the steering intermediate shaft joint bolts for tightness every 60,000 miles (96,000 km) or annually, whichever occurs first. Tighten bolts to torque specified in the **Torque Specification Chart** at the end of this section. **Do not over tighten.**

Lubrication Points

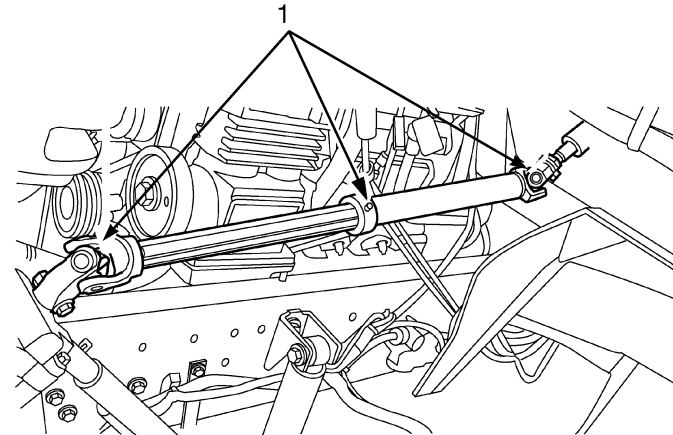

3813021

Typical steering shaft

1. Lubrication point (3)

The steering shaft is lubricated at the three points shown above. For the correct maintenance interval, refer to the **Lubrication and Maintenance Intervals Chart** in the **Maintenance Intervals and Specifications** section.

Maintenance

Power Steering

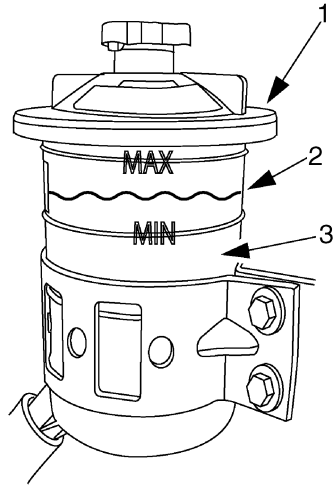

3813022

Power Steering Reservoir

1. Filter access cap
2. Fluid level
3. Internal power steering fluid filter

NOTE: The SmartTrac™ Brake System receives fluid pressure from the power steering pump to provide power assist during braking.

Periodically replace the power steering fluid.

Whenever the hydraulic (power steering) system has been drained and refilled, bleed air from the system before returning the vehicle to service. Failure to properly bleed the hydraulic system can result in shimmy complaints and / or steering wheel oscillation when striking a bump.

Consult your IC Bus® dealer or IC Bus® Service Manual for the proper procedures for filling and bleeding the system.

The power steering fluid filter is located inside the power steering reservoir. To remove the filter, unscrew the large cap on the power steering reservoir and unscrew the filter. Reverse the procedure to install the new filter.

Refer to the **Lubrication and Maintenance Interval Chart** at the back of this section for the fluid and filter replacement intervals.

DEF Tank Filling

 **CAUTION**

To prevent vehicle and / or engine component damage, proper care should be taken when handling, dispensing, or transporting DEF, as it is corrosive to some metals and materials.

 **CAUTION**

To prevent your engine from being de-rated due to DEF contamination and / or loss of DEF purity, before using containers or funnels that will be used to dispense, handle, or store Diesel Exhaust Fluid (DEF), ensure to wash thoroughly to remove any contaminants and then rinse with distilled water. **DO NOT USE TAP WATER** to rinse components that will be used to store or deliver DEF fluid. If no distilled water is available, rinse with tap water and then rinse with diesel exhaust fluid (DEF).

The DEF tank filler cap is located on the right-side of the vehicle behind an appropriately labelled access door. The DEF filler cap on this vehicle is BLUE in order to differentiate it from the fuel filler cap. Use only ISO 22241-1 approved DEF to ensure proper purity and concentration.

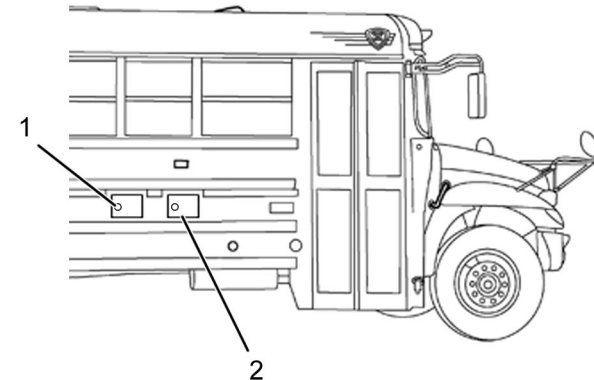

0000055775

Typical CE Bus Fuel and DEF Access Door Locations

1. Fuel access door
2. DEF access door

Exhaust Diesel Particulate Filter (DPF)

Regeneration

Collected soot particles in the Diesel Particulate Filter (DPF) are automatically burned off through normal regeneration (initiated by normal exhaust heat during the normal operation of the vehicle). If conditions for normal regeneration cannot be achieved, it may be necessary to perform a parked regeneration as indicated by the Instrument Panel Gauge Cluster warning indicators. See the Parked Regeneration Procedure in **SECTION 9 — DRIVING**.

Cleaning

If on-vehicle regeneration is unsuccessful at removing soot from the DPF, the DPF may need to be removed from the vehicle and be cleaned with the appropriate machinery and processes.

Ash residue in the DPF comes primarily from fuel and oil additives and will not burn or pass through the DPF. Ash residue accumulates very slowly in the DPF, but must eventually be removed to prevent excessive exhaust backpressure. If the DPF needs to have nonregenerable soot or the ash residue removed, please take the vehicle to an IC Bus dealer.

Transmission

Transmission Fluid Level

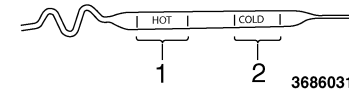

1. Hot fluid level
2. Cold fluid level

- Check fluid level with the parking brake applied, the engine running at idle speed, and the transmission in neutral. Consider the transmission fluid temperature when determining the correct level.
- When the transmission fluid is cold, the fluid level should fall within the COLD run band. When the transmission fluid is hot, the fluid level should fall within the HOT run band. Add fluid as required. **Do not overfill** or the transmission will overheat.
- Check the shift linkage for proper operation.
- Check operation of transmission neutral safety switch. Try to start the vehicle in all shift selector positions. The starter should only operate when the shift selector is in N (Neutral), or P (Park), if supplied.
- Refer to the **Lubrication and Maintenance Interval Chart** and the **Lubricant and Sealer Specifications Chart** in the **Maintenance Intervals and Specifications section** for information on automatic transmission fluids and fluid and filter change intervals.

Tires

Tire Warnings



WARNING

To prevent personal injury and / or death, or damage to property, for field maintenance, only inflate and load tires to the maximum of the least-rated tire on the axle. Due to tire manufacturers re-marking tires to conform to the SI (metric) system, tires marked with old and new loads or inflation pressures could be placed on the same vehicle.



WARNING

To prevent personal injury and / or death, or damage to property, always maintain your tires in good condition. Frequently check and maintain correct inflation pressures as specified by tire manufacturers. Inspect periodically for abnormal wear patterns and repair / replace cut or broken tire casing. Always use experienced, trained personnel with proper equipment and correct procedures to mount or remove tires and wheels.



WARNING

To prevent personal injury and / or death, or damage to property, always follow these instructions when mounting tires on wheels:

- Only personnel who have had proper training and experience should mount or remove tires from rims or wheels.
- Use only heavy-duty rims or rims approved for radial tires. It may be necessary to contact your wheel and rim distributor to determine if your rims are approved for radial tires.
- If a tube is to be used, ensure special radial tire tubes are used because of the increased flexing of the sidewalls on radial tires.
- Never use antifreeze, silicones, or petroleum-based lubricants when mounting radial tires. Only an approved lubricant should be used as an aid for mounting tires.
- Always inflate tires in a safety cage.



WARNING

To prevent personal injury and / or death, or damage to property:

- Do not mix stud-piloted wheels or fasteners with hub-piloted wheels or fasteners. Mixing wheel types may cause premature wheel failure.
- Do not change from steel wheels or a steel inner and aluminum outer wheel combination to aluminum wheels without changing the mounting hardware since the thicker aluminum wheels require longer studs. In some cases with flange nut mounting systems, changing the hub and stud assembly may be required. Improperly mixing components could cause wheel or fastener failures.
- Do not mix foreign (not made in North America) wheel mounting parts with domestic (made in North America) parts. Many foreign wheel components look similar to, but are not exactly the same as, domestic made components. Mixing components can cause wheel or fastener failures.



WARNING

To prevent personal injury and / or death, or damage to property, do not mount tube-type tires on tubeless wheels or tubeless tires on tube-type wheels.

Tire Maintenance

Preserving proper inflation pressure is a very important maintenance practice to ensure safe vehicle operation and long life for the tires.

Failure to maintain correct inflation pressure may result in sudden tire destruction, improper vehicle handling, and may cause rapid and irregular tire wear. Therefore, inflation pressures should be checked daily and always before long-distance trips.

Follow the tire manufacturer's recommended cold inflation pressure for the tire size, type, load range (ply rating), and axle loading typical for your operation. (Each steer axle tire load will equal 1/2 steer axle loading. Each drive tire load will be 1/4 the axle loading, if fitted with four tires.)

Checking Inflation

Always check inflation pressure when tires are cold. Never bleed air from hot tires to relieve normal pressure buildup. Normal increases in pressure during operation will be 10 - 15 psi (69 - 103 kPa), which is allowable in truck tires. Tires on the same axle should have the same air pressure as the corresponding other tire(s) on that axle. Steer tires should be within a 3 psi (21 kPa) pressure range of each other. All drive tires should be within a 5 psi pressure range of each other. Tag or pusher axle tires on the same axle should be within a 5 psi (34 kPa) pressure range of each other.

To minimize rim corrosion, it is particularly important to keep moisture from the inside of tires and proper selection of air compressor equipment, proper air line routing, and the use of shop air dryers is strongly recommended to avoid moisture in the high-pressure air used for tire inflation.

Underinflation

Tires should not be permitted to become underinflated. Increased flexing due to underinflation causes heat buildup within the tire components. This leads to reduced strength, breakdown of the rubber compounds and possible separation of the tire components (such as ply and tread separation and reduced retreadability).

Underinflation is also the primary cause of blowouts. In addition, low inflation causes an increase in rolling resistance. This results in reduced fuel mileage, a loss in tread life, and uneven wear due to increased tread movement. To determine proper inflation, refer to the tire inflation range stated on the tire sidewall and the tire manufacturer's tire load-pressure charts.

Inspection

Check condition of tires for abnormal wear patterns and proper inflation pressures. Cut or broken tire casing must be repaired or replaced.

Tires should be inspected for the following conditions. If any are present, the tire should be removed and repaired, retreaded, or scrapped as the condition indicates.

- Any blister, bump, or raised portion anywhere on the surface of the tire tread or sidewall (other than a bump made by a repair). These indicate the start of internal separation.
- Any cut that reaches to the belt or ply cords or any cut that is large enough to grow in size and depth.
- Any nail or puncturing object.
- If any stone or object is held by a tread groove and is starting to drill into the tread base, remove the object.

Proper tire inflation, toe-in adjustment, loads, and road speeds are important factors governing tire life, steering ease, maneuverability, fuel economy, and ride quality.

Loads



To prevent personal injury and / or death, or damage to property, do not load tires beyond their rated capacity as this decreases tire life, requiring more frequent replacement of tires. Overloading creates an unsafe condition that may result in sudden air loss from a tire failure resulting in an accident.

Maintenance

NOTE: The load rating of the tires installed on your vehicle at the time of your vehicle's production is at or in excess of the Gross Axle Weight Rating (GAWR) generally found on a label on the bulkhead above the driver. When replacing tires, be sure that the replacement tire load rating (listed separately in pounds and kilograms on the tire sidewall for single or dual applications) multiplied by the number of tires on that axle is equal to or higher than the specific listed Steer Axle or Drive Axle GAWR. Failure to do so will adversely affect maximum load-carrying capacity. Tires with the same size specification do not always have the same load specification.

Dual Tires Matching

Dual tires should be matched using tires of equivalent size. Tires which differ more than 1/4 in (6 mm) in diameter or 3/4 in (19 mm) in circumference should not be mounted on the same dual wheel assembly.

Dual Tires Mixing

NOTE: Never mix bias and radial tires on this vehicle.

It is recommended for best overall performance that only radial tires be used on this vehicle.

Never mix different tire sizes or constructions on the same axle.

Rotation

- Steer tires that have developed some type of irregular wear pattern can be rotated to drive axles if rib tires are being used on all wheel positions. Applying steer tires to a drive position will often wear off the irregularities and they can be moved back to the steer axles or run out to retread stage on the rear axle.
- Another rotation possibility for fleets with rib tires in all wheel positions is to break in the new steer tires in the drive axle positions, then move them to steer axles. This will wear away tread rubber relatively quick in the early life of a tire when it is most likely to develop an unusual wear pattern.
- Drive axle tires may be placed on the other end of the same axle so that direction of rotation is reversed. This is often helpful if a heel and toe or alternate wheel nut wear pattern has developed.

Rotation Is Advisable

1. If front (steering) axle tires become irregularly worn, move to rear position.
2. In a dual assembly, reverse the position of the tires if one tire wears much faster than its mate.
3. On the drive axle, if heel and toe wear or alternate wheel nut wear occurs, rotating the tires from one end of the axle to the other end of the axle may help even out this wear.

Tire Replacement

NOTE: Retread tires are not recommended for use on steering axles of trucks.

- **Front (Steering) Axle - Tires must be removed when tread is worn to 4/32 in (3 mm) or less. Retread or rotate worn tires to drive position.**
- **Rear Axles - Tires must be removed when tread is worn to 2/32 in (2 mm).**

If rib tire is used on front axle and lug- or off-road-type on rear axle positions:

- **Front (Steering) Axle - Replace tires at front wheels when tread is worn to 4/32 in (3 mm) or less.**
- **Rear Axles - Tires must be removed when the tread is worn to 2/32 in (2 mm) or less. Tires identified with the word regroovable molded on the sidewall can be regrooved. A minimum of 3/32 in (2.38 mm) of undertread must be left at the bottom of the grooves.**

Wheel and Tire Balancing

Out-of-round or out-of-balance wheels or tires can cause vehicle vibration and bounce, and shimmy. Replace damaged or out-of-round wheels. Out-of-round tires and wheel assemblies can be corrected by rechecking the tire relative to the wheel. The tire and wheel assembly should thereafter be dynamically balanced and reinspected while spinning for an out of round condition.

Wear

Radial tires can exhibit the following types of normal wear patterns, even, erosion, or chamfer.

Even Wear is a sign that the tire is being properly used and maintained.

Erosion Wear has also been called rolling wear, channel, or river wear. Erosion wear is found more often at free rolling tires. This is an indication that the tire is being used in a slow wearing operation. What happens is that the belt plies are held very rigid and the tread is not allowed to distort as it passes through the contact area. Wear will only occur at the edge of the tread. No corrective action required. If erosion gets to be 2/32 in (2 mm) or more, the tire may be rotated to a drive axle.

Chamfer or Shoulder Wear, with tires inflated properly, is a normal tendency of most radial tire designs. If both inside and outside shoulders are wearing evenly around the tire, no further action is required. Overinflation is not effective in correcting this effect.

Irregular Wear

If irregular wear is present, check the axle alignment, tire pressure, wheel balance, shock and suspension component condition, and wheel bearing end play.

This condition not only shortens tire life, but will adversely affect the handling of your vehicle.

Maintenance

Rotating tires from one wheel position to another is a way often used to even out many types of irregular wear or to avoid it altogether. See **Tires – Rotation** for more information. Some of the more effective tire rotation programs are:

Irregular wear can be minimized by:

- Using the correct inflation pressure for the load being carried.
- Maintaining proper front wheel alignment - **especially toe-in** - to specifications.
- Maintaining proper tire and wheel balance.
- Maintaining shock absorbers and suspension components.
- Maintain proper wheel bearing adjustment .

Use of Tire Chains

Refer to chain manufacturer's recommendation for correct tire chain usage, installation, and removal.

Wheels

Wheel and Wheel Nut Maintenance and Installation



To prevent personal injury and / or death, or damage to property, always follow these instructions when mounting tires on wheels:

- Only personnel who have had proper training and experience should mount or remove tires from rims or wheels.
- Use only heavy-duty rims or rims approved for radial tires. It may be necessary to contact your wheel and rim distributor to determine if your rims are approved for radial tires.
- If a tube is to be used, ensure special radial tire tubes are used because of the increased flexing of the sidewalls on radial tires.
- Never use antifreeze, silicones, or petroleum-based lubricants when mounting radial tires. Only an approved lubricant should be used as an aid for mounting tires.
- Always inflate tires in a safety cage.

**WARNING**

To prevent personal injury and / or death, or damage to property:

- Do not mix stud-piloted wheels or fasteners with hub-piloted wheels or fasteners. Mixing wheel types may cause premature wheel failure.
- Do not change from steel wheels or a steel inner and aluminum outer wheel combination to aluminum wheels without changing the mounting hardware since the thicker aluminum wheels require longer studs. In some cases with flange nut mounting systems, changing the hub and stud assembly may be required. Improperly mixing components could cause wheel or fastener failures.
- Do not mix foreign (not made in North America) wheel mounting parts with domestic (made in North America) parts. Many foreign wheel components look similar to, but are not exactly the same as, domestic made components. Mixing components can cause wheel or fastener failures.

**WARNING**

To prevent personal injury and / or death, or damage to property, when installing the tire and rim assembly on disc brake-equipped axles, ensure the tire valve stem clears the brake caliper. The use of either an International® truck valve stem retainer or a tire manufacturer's stem forming tool is the only acceptable method of obtaining clearance when necessary. Failure to obtain proper clearance may result in rapid tire deflation.

Wheel Nut Torque Maintenance

Tighten and maintain wheel and rim mounting nuts to the proper torque. Loose nuts or overtightened nuts can lead to premature wear and possible failure of the wheel, rim, and / or mounting hardware.

Hub-Piloted Wheel Installation Procedures**WARNING**

To prevent personal injury and / or death, or damage to property, use only the same type and style wheels and mounting hardware to replace original parts. Failure to do so may result in an assembly that looks fine but does not fit together properly. This could cause wheel or fastener failures.

Maintenance

Out-of-round tires and wheel assemblies can sometimes be corrected by reclocking the tire relative to the wheel.

Tightening procedure for disc wheels with flange nuts (hub-piloted).

1. Clean the mating surfaces of the hub, drum, and wheel(s) as well as the wheel studs and wheel nuts with a wire brush prior to assembly.
2. Lubricate the two-piece wheel nuts by putting two drops of oil in the slot between the nut and washer and spin the washer to spread the oil around the nut-to-washer contact surface.
3. Carefully lubricate the wheel stud threads by wiping them with a freshly oiled cloth. Do not get the oil on any other surfaces or the wheel clamping effectiveness will be reduced.
4. To prevent aluminum wheels from getting stuck on the hub due to corrosion, apply a thin coat of antiseize compound or disc brake corrosion control grease to the hub pilot pads only.
5. Slide the inner wheel (if duals) or steer wheel over the wheel studs and onto the pilot pads of the hub. Care must be taken to avoid damage to the stud threads while positioning the wheel. Ensure that the wheel is resting on the pilot pads and is against the brake drum.
6. Hand start all wheel nuts to avoid cross-threading.
7. Starting with the nut at the 12 o'clock position and using the appropriate star or crisscross pattern (see wheel nuts

torque sequence diagram), run the wheel nuts down the wheel studs with an impact wrench until they are snug against the wheel. The purpose of this step is to snug the wheel(s) in the correct position, not to apply the final torque. The tightening of each nut should be stopped immediately when the wheel is contacted, resulting in a wheel nut torque well below the final specified torque.

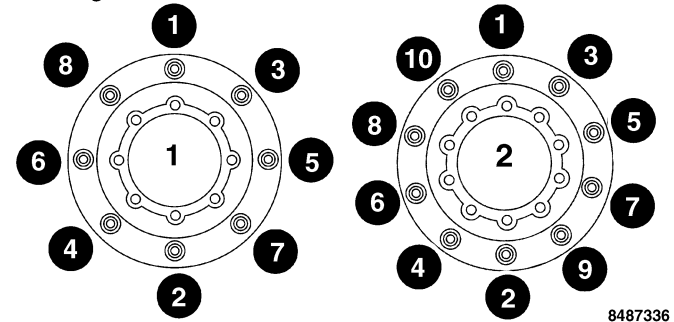

1. Flange nut mount – 8 stud
 2. Flange nut mount – 10 stud
8. Use a calibrated torque wrench to apply the specified torque to each wheel nut in the sequence specified in the wheel nuts torque sequence diagram above. Refer to **Maintenance Intervals and Specifications Section** for proper torque values.

9. All wheels undergo a process called joint settling when placed in service after a wheel installation has been performed. This process results in a reduction in the torque on the wheel nuts. To correct this condition, operate the vehicle normally for approximately 50 miles (80 km), then use a calibrated torque wrench to retorque the wheel nuts to specification using the appropriate pattern shown in the wheel nuts torque sequence diagram.
10. As part of a daily pretrip inspection, look for loose or missing wheel nuts. Also look for rust streaks extending outward from the wheel nuts; this can be an indicator that one or more wheel nuts are loose, even if they cannot be turned by hand. Normal periodic maintenance should also include checking the wheel nut torque with a torque wrench.

Windshield Wiper

Wiper Blade Assembly Replacement

1. Press the plastic lever at the wiper blade assembly to the wiper arm hinge.
2. Slide the wiper blade assembly up the wiper arm and detach it.

3. Snap the new wiper blade assembly on to the arm in the opposite direction of the removal.
4. Check to see that the rubber wiper blade rests flat against the windshield.

Wiper Arm Removal / Replacement

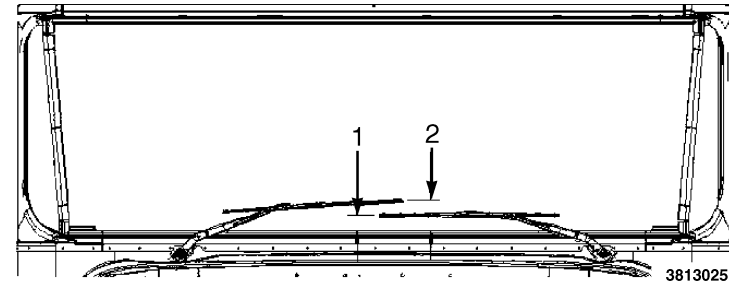

1. Driver-side measurement (2.06 in. +12 in. -20 in.)
2. Passenger-side measurement (3.98 in. -12 in. +20 in.)

Turn the windshield wiper switch to the on position. Allow wipers to complete a full cycle and turn OFF the switch. Wipers should stop in the parked position.

Removal

1. Locate and disconnect the wiper / washer supply hose from the supply port on the cowl.
2. With the wipers in the parked position, place a mark on the base section of the wiper arm assembly. Make a corresponding mark on the boot covering the drive mechanism.
3. Locate and remove the plastic cap cover at the wiper arm base.
4. With the cap removed, loosen and remove the nut securing the wiper arm to the drive stud. Remove the wiper arm from the drive stud by pulling the wiper arm outward.

Installation

1. Align the marks at the base of the wiper arm assembly and the drive stud boot.
2. Install the wiper arm on the drive stud. Confirm the correct height of each wiper from the base of the windshield per the figure shown.
3. Place the wiper arm retaining nut on the drive stud and tighten. Refer to the **Torque Chart** in the **Maintenance Intervals and Specifications** section for correct torque specification.
4. Replace the plastic cap on the wiper arm assembly covering the attachment nut.
5. Reconnect the wiper / washer supply hose on the cowl.
6. Operate the windshield wipers and washer to verify correct operation. If wipers contact each other or the window frames during operation, or if they look close and might contact each other or the windshield frame, adjust the wiper arm orientation as needed.

SECTION 13 — MAINTENANCE INTERVALS AND SPECIFICATIONS

Maintenance Intervals

All new vehicles are factory-lubricated. Once the vehicle is in operation, regular lubrication and maintenance intervals (based on the type of service and road conditions) must be established and performed. Load weight, vehicle speed, road conditions, and weather conditions all contribute to lubrication frequency. Performing thorough lubrication and maintenance at the specified intervals will ensure an outstanding vehicle life and will reduce overall operating expense.

The **Lubrication and Maintenance Interval Chart** contains an extensive list of components and systems. Listed items and systems must be regularly inspected, serviced, and / or replaced to maximize vehicle availability and minimize unexpected failures. Recommended synchronized intervals are shown for each item. This chart can serve as a convenient one-stop reference to research most maintenance needs.

Only lubricants of superior quality, such as Fleetrite® lubricants, should be used. The use of inferior products will reduce the service life of the vehicle or result in failure of its components. The use of Fleetrite® lubricants is recommended for optimum performance.

Maintenance intervals provided in this manual are for normal highway and environmental service conditions.

These intervals may be expressed in miles (kilometers), hours of operation, and / or months of operation. It is important to note

that in high duty cycle types of operation and / or where operating conditions are extremely severe (such as in deep water, mud or unusually dusty conditions), the vehicle may require lubrication much more frequently than specified in this manual.

The synchronized A and B service intervals are designed to coordinate maintenance activities and to provide the appropriate levels for servicing components. Following the service intervals minimizes the number of times per year that the vehicle must be brought into the shop. In addition to the A and B service intervals, the Special Service Interval column is provided for items that need infrequent servicing. In most cases, these service intervals represent the recommended maximum intervals. For some components, however, the manufacturer's recommended maintenance intervals may have been shortened to allow synchronization with other maintenance tasks.

The maintainer may wish to synchronize engine related items with other lubrication / maintenance intervals in order to reduce downtime, even though the recommended intervals in the Engine Manual may be longer. **Engine Manual maximum intervals (based on the actual operating conditions specified in that manual) must never be exceeded.**

NOTE: For vehicles equipped with Cummins® B engines, refer to Cummins QuickServe® Online, your Cummins Engine Operation Manual, or contact a certified Cummins repair location for specific engine maintenance intervals, capacities, and instructions.

Maintenance Intervals and Specifications

Lubrication and Maintenance Interval Chart Symbols Key

Symbol	Interval Definition
A	A interval: 10,000 miles (16,000 km) / 300 hours / 6 months
B	B interval: 20,000 miles (32,000 km) / 600 hours / 12 months

Lubrication and Maintenance Interval Chart Notes

NOTE 1: Use a hand-pumped grease gun for optimal grease distribution within the component joint.

NOTE 2: Lubricate Kingpin thrust washers with vehicle weight on tires. Kingpins and kingpin bushings must be lubricated with weight off of the wheels and tires.

NOTE 3: Certain services are performed at Special Intervals or in addition to A or B Service when the interval dictates.

Lubrication and Maintenance Interval: Bus – CE (Diesel)

System	Item	Intervals	Special Interval (3) : miles (km) / hours / months
Pre-Trip Inspection	Pre-trip inspection Items listed in Section 2 – Check All		
Front Axle	Wheel Bearing-Oil Type – Check Level	A, B	
	Axle U-bolts – Retorque		At first 1,000 miles (1,600 km) then every 36,000 miles (58,000 km) thereafter
	Drag Link – Lubricate (1)	A, B	
	Kingpins and Bushings – Lubricate (1,2)	A, B	
	Shock Absorbers – Inspect	A, B	
	Suspension Fasteners / Components – Check	A, B	
	Tie Rod Ends – Lubricate (1)	A, B	
	Wheel Bearings – Check End-play	B	
	Wheel Bearing-Grease Type – Repack		30,000 (48,000) / – / 6
Wheel Bearing-Oil Type (including synthetic) – Change Oil		96,000 (60,000) / – / 6	

Lubrication and Maintenance Interval: Bus – CE (Diesel) (cont.)

System	Item	Intervals	Special Interval (3) : miles (km) / hours / months
Electrical	ABS Sensors - Reseat	A, B	
	Alternator-Starter-Battery – Check	B	
	Electrical lines routing and clipping (lines are not tangled, crimped or pinched or rubbing against surfaces); not spliced or taped; insulation not cut, cracked, chafed or worn. – Inspect	B	
	Engine Start and Gauge / Warning Lights – Check	A, B	
	Instrument Readings Proper – Check	A, B	
	Power Distribution Center: Corrosion throughout case and on pins of fuses and breakers – Inspect	B	
Steering	Power Steering Filter – Replace		500,000 (800,000) / 1,500 / 60
	Power Steering Fluid – Change		40,000 (64,000) / – / 12
	Power Steering Fluid – Check Level	A, B	
	Steering Gear – Lubricate	A, B	ATTN: Install grease slowly at low pressure. Power grease guns may blow out seals.
	Steering Intermediate Shaft U-Joints / Slip Joint – Lubricate	A, B	
	Steering System – Check Tightness	A, B	
	Steering Intermediate Shaft U-Joints – Retorque		60,000 (96,000) / 1,500 / 24
Drive Shaft SPL	U-Joints – Lubricate; Slip Joint Boot – Inspect	B	
Drive Shaft Non-booted Slip Joint	U-Joints and Slip Joint – Lubricate		5,000 (8,000) / – / 3

Maintenance Intervals and Specifications

Lubrication and Maintenance Interval: Bus – CE (Diesel) (cont.)

System	Item	Intervals	Special Interval (3) : miles (km) / hours / months
Brakes – Air	Air Compressor Discharge Line – Check blockage		50,000 (80,000) / 1,500 / 24
	Air Dryer Desiccant – Replace		AD-9 Model: 250,000 miles (400,000 km) / – / 24 Other Models: 125,000 miles (200,000 km) / – / 12
	Air Dryer Heater & Purge Valve – Check		AD-IP: 12; AD-9: 24
	Air Tanks (all) – Drain Water	A, B	
	Air Wet Tank – Drain Water	A, B	
	Brake Chamber Rod Travel – Check	A, B	
	Governor Cut-in / Cut-out Pressure – Check	A, B	
	Low Air Pressure Warning Alarm – Check	A, B	
	Parking Brake Operation – Check	A, B	
	Rotors / Drums, Calipers, Chambers, Hoses, etc – Check for wear / damage	A, B	
	S-Cam Bushings – Lubricate	A, B	
	Service Brakes Operation – Check	A, B	
	Shoes – Check for wear and drag	A, B	

Lubrication and Maintenance Interval: Bus – CE (Diesel) (cont.)

System	Item	Intervals	Special Interval (3) : miles (km) / hours / months
Brakes – Hydraulic	Brake Pedal Holds Pressure – Check	A, B	
	Discs, Calipers, Lines, etc – Check for wear / damage	A, B	
	Hydraulic Brake Fluid – Change		Every 2 years from the date of manufacturing
	Master Cylinder Cap – Check Vent for Obstruction NOTE: If obstruction is observed, replace cap.	A, B	
	Master Cylinder – Check Fluid Level	A, B	
	Parking Brake Cable – Check condition	A, B	
	Parking Brake Operation – Check	A, B	
	Power Steering – Check	A, B	
	Service Brakes Operation – Check	A, B	
Cooling System	Coolant – Check Level	A, B	
	Coolant Filter (if equipped) – Replace		150,000 (241,000) / 6,000 / 30
	Extended Life Coolant – Add Extender	Refer to Engine Operation and Maintenance Manual	
	Extended Life Coolant – Replace		
	Fan Blade / Shroud – Check Damage / Contact	A, B	
	Fan Clutch – Check	A, B	
	Radiator & Charge Air Cooler (CAC) Fins – Check for Blockage	A, B	

Maintenance Intervals and Specifications

Lubrication and Maintenance Interval: Bus – CE (Diesel) (cont.)

System	Item	Intervals	Special Interval (3) : miles (km) / hours / months
Engine	NOTE: For vehicles equipped with Cummins® B engines, refer to Cummins QuickServe® Online, your Cummins Engine Operation Manual, or contact a certified Cummins repair location for specific engine maintenance intervals, capacities, and instructions.		
	Air Filter – Check Restriction	Refer to Engine Operation and Maintenance Manual .	
	Air Filter – Replace		
	Air Induction System – Check looseness / leaks		
	Engine Oil Level – Inspect		
	Engine Oil and Filter(s) – Replace		
	Fan Belt – Inspect		
	Fan Belt Auto Tensioner – Inspect		
	Fuel Filter – Drain Sediment Bowl (I-6 only)		
	Fuel Filter – Drain Separated Water		
	Fuel Filter – Replace		
	Valve Lash Adjustment (I-6 only)		
Fuel Tank	Fuel Sender, Hose Connections – Check for loose connectors		
	Fuel Tank(s) – Drain and flush		12 months
	Fuel Tank – Drain Water	B	
Exhaust System	Diesel Exhaust Fluid (DEF) Supply Module Filter – Replace	200,000 (322,000) or 6,500 hours	
	Diesel Particulate Filter (DPF) – Service	Refer to Engine Operation and Maintenance Manual .	
	Pipes / Diesel Oxidation Catalyst / Diesel Particulate Filter / Muffler – Inspect for leakage / looseness	A, B	

Lubrication and Maintenance Interval: Bus – CE (Diesel) (cont.)

System	Item	Intervals	Special Interval (3) : miles (km) / hours / months
Transmission	Automatic Trans Fluid – Check Level	A, B	
	Automatic Trans Fluid Filter(s) – Replace		Allison 1000 PTS – Spin-On Control Main filter with any fluid, first 5,000(8,000) / – / – With mixed conventional and Synthetic Trans fluid for Main or Lube / Aux filter – every 50,000 (80,000) / – / 24 With Synthetic Trans fluid only for Main or Lube / Aux filter – every 50,000 (80,000) / – / 24 Allison 2000 – controls filter with any fluid type At first 5,000 (8,000) / 200 / – and then every 50,000 (80,000) / – / 24 thereafter Allison MD Main Filter with any fluid type At first 5,000 (8,000) / 200 / – and then regular interval thereafter
	Automatic Trans Fluid Filter(s) – Replace (Continued)		Allison MD Main Filter and Lube Filter with conventional or conventional / synthetic mixed fluid every 25,000 (40,000) / 1,000 / 12 Allison Gold MD Main and Lube Filters with factory filled synthetic fluid every 150,000 (241,000) / 4,000 / 48
	Conventional or Conventional / Synthetic Mixed Automatic Trans Fluid – Replace		Allison MD – 25,000 (40,000) / 1,000 / 12 Allison 1000 PTS – 50,000 (80,000) / – / 24 Allison 2000 – 50,000 (80,000) / – / 24
	Factory-filled Synthetic Non-Mixed Automatic Trans Fluid – Replace		Allison 1000 PTS – 100,000 (160,000) / – / 48 Allison 2000 – 100,000 (160,000) / – / 48 Allison MD – 150,000 (240,000) / 4,000 / 48 (Allison GOLD FILTERS required)

Maintenance Intervals and Specifications

Lubrication and Maintenance Interval: Bus – CE (Diesel) (cont.)

System	Item	Intervals	Special Interval (3) : miles (km) / hours / months
Transmission (Cont.)	Neutral Start Switch – Check Function	A, B	
	Shift Selector / Linkage – Check Function	A, B	
Rear Axle	Axle Flange Nuts – Retorque	B	
	Axle U-bolts – Retorque		At first 1,000 miles (1,600 km) then every 36,000 miles (58,000 km) thereafter
	Rear Axle Wheel Ends – Inspect for leaks, lube level / condition, and check end play with dial indicator.		100,000 (160,000) / – / 12 Also at brake lining service If wheel end play is found to be outside the 0.001 in. to 0.005 in. specification, or lube condition is contaminated or low, then perform a full wheel end tear down. Inspect bearings, spindle, and spindle nuts for excessive wear and replace as necessary.
	Rear Axle Wheel Ends – Full tear down inspection of all wheel end components, regardless of condition of lube and wheel bearing endplay.		800,000 (500,000) / – / 60
	Rear Axle With Petroleum Oil – Change		60,000 (96,000) / – / 12
	Rear Axle With Synthetic Oil – Change		Dana® Spicer®: 180,000 (288,000) / – / 36 Meritor: 250,000 (400,000) / – / 36
	Ride Height – Check	B	
Stable Ride Suspension Fasteners / Components – Check	A, B		

Lubrication and Maintenance Interval: Bus – CE (Diesel) (cont.)

System	Item	Intervals	Special Interval (3) : miles (km) / hours / months
Tires / Wheels	Air Pressure – Check	A, B	
	Spin Balance		At time of tire mounting
	Wear and Condition – Check	A, B	
	Wheel Stud Nuts – Retorque	A, B	
Body / Components	Accelerator Pedal – Check Function	A, B	
	Air Conditioner (Optional) – Check Performance	B	
	All Seat Base Bolts	B	
	Body – Check loose, damaged, missing parts	A, B	
	Body Mounting Bolts – Inspect Tightness		1 month or 1,500 miles (2,414 km) and then 3 months or 3,000 miles (4,828 km) thereafter
	Chassis – Check for loose, damaged, missing, parts	A, B	
	Entry Door – Check Operation	A, B	
	Emergency Windows Slides – Lubricate		Every 12 months
	Emergency Doors / Exits and Buzzers – Check	A, B	
	Fluid Leaks – Check	A, B	
	Headlights, Bright / Dim / Daytime – Check	A, B	
	Heater Hoses and Connections – Check Condition		12 months NOTE: See Heater and Coolant Hose Inspection and Replacement Guide in this section for additional information.
	Inspect and Clean Step Well and All Other Heater Cores and Blower Areas	A, B	NOTE: For units without filter, more frequent cleaning may be required.

Maintenance Intervals and Specifications

Lubrication and Maintenance Interval: Bus – CE (Diesel) (cont.)

System	Item	Intervals	Special Interval (3) : miles (km) / hours / months
	Lights Interior / Exterior – Check	A, B	
	Optional Components As Equipped – Check	A, B	
	Post Trip Inspection Feature – Check	A, B	
	Roof Hatch(es) – Check Operation	A, B	
	Safety Equipment As Equipped – Check	A, B	
	Seat Belt(s) Bolts – Check Operation / Condition	A, B	
Body / Components (Cont.)	Step Well and All Heater Core Air Filters – Inspect / Clean or Replace	A, B	
	Undercoating Inspection		Inspect the undercoating of school buses annually and recoat as required.
	Warning lights, Stop Arm(s), Crossing Gate, Entrance door / Warning lights Interaction – Check	A, B	

Unit Refill Capacities

Air Conditioner Refrigerant

See air conditioner manufacturer's Service / Operator Manual for aftermarket bus A/C system specifications.

Axle-Rear

Axle	Axle Lube Capacities Pints (Liters)
Dana® Spicer® S11-130, S14-130, S16-130,	16 (7.5)
Dana® Spicer® 17060S, 19060S, 21060S, 23060SH	28 (13.2)
Meritor MS-17-14X-3DFL, MS-19-14X-3DFL, MS-21-14X-3DFL,	33.6 (15.9)
Meritor RS-23-160	39.5 (18.7)

Cooling System Refill Capacities

Cooling system capacities vary greatly due to variations in bus length, number of heaters and engine model. Total capacity may range from 9 - 15 gallons.

- For vehicles equipped with Navistar® N9 or N10 engines, fill with a 50/50 mixture of Shell Rotella® Extended Life Coolant (ELC) (RED) concentrate and demineralized or distilled water, Shell Rotella® ELC 50/50 Premix (RED), Fleetrite® NOAT ELC (RED) concentrate and demineralized or distilled water, or Fleetrite® NOAT ELC 50/50 Premix (RED).
- For vehicles equipped with Cummins® B6.7 engines, fill with a 50/50 mixture of Shell Rotella® Extended Life Coolant (ELC) (RED) concentrate and demineralized or distilled water, or Shell Rotella® ELC 50/50 Premix (RED).

If the system has been flushed with water or cleaner, a significant amount of the rinse water will remain in the system. In this case refilling with a mixture with a higher percentage (60 to 66%) of coolant concentrate is advised in order to achieve a final mixture closer to 50/50. Fill the system and run the vehicle until the thermostat opens. Before adding any fluid, check the coolant concentration and add additional water or concentrated undiluted coolant to adjust the concentration. Run the vehicle and retest for coolant volume level (set to MAX line) and concentration level.

Maintenance Intervals and Specifications

Diesel Exhaust Fluid Tank

Diesel Exhaust Fluid (DEF) tank refill capacity varies depending on the vehicle models. Its total capacity may range from 7 to 23 gallons (26 - 87 liters). The tank is typically located on the right side of the bus behind an access door.

Engine Crankcase

For specific engine crankcase capacities refer to separate **Engine Operation and Maintenance Manual** provided with vehicle.

NOTE: For vehicles equipped with Cummins® B6.7 engines, refer to Cummins QuickServe® Online, your Cummins Engine Operation Manual, or contact a certified Cummins repair location for specific engine maintenance intervals, capacities, and instructions.

Power Steering Systems

Steering Gear	Power Steering Fluid Volume (pints / liters)
M-100	8.4 / 3.9*
TAS40	7.4 / 3.5*
TAS66	8.4 / 3.9*
THP45	7.4 / 3.5*

Power Steering Systems (cont.)

Steering Gear	Power Steering Fluid Volume (pints / liters)
THP60	8.4 / 3.9*
* Approximate refill quantity, refer to power steering reservoir for proper fill marks.	

Transmission

Transmission Model	Transmission Fluid Volumes Pints (Liters)
Allison Automatic – 1000 PTS 5 Speed	38 (18)*
Allison Automatic – B-300 5 Speed	29 (14)*
Allison 5 Speed Automatic – 1000 PTS	38 (18)*
Allison 5 Speed Automatic – 2100 PTS	38 (18)*
Allison 5 Speed Automatic – 2200 PTS	38 (18)*
Allison 5 Speed Automatic – 2500 PTS	38 (18)*
Allison 5 Speed Automatic – 2550 PTS	38 (18)*
Allison 5 Speed Automatic, School and Shuttle Bus – 3000 PTS	58 (27)*
* Approximate refill quantity (less than initial fill since a portion of the used fluid remains in external circuits and transmission cavities). Check at operating temperature and top off as required.	

Tire and Rim Combinations**Approved Tire and Wheel Combinations**

Tire Size	Rim Width
9R22.5	6.75, 7.50
10R22.5	6.75, 7.50
11R22.5	7.50, 8.25
12R22.5	8.25, 9.00
225/70R19.5	6.75
235/80R22.5	6.75, 7.50

Approved Tire and Wheel Combinations (cont.)

Tire Size	Rim Width
245/70R19.5	6.75, 7.50
255/70R22.5	6.75, 7.50, 8.25
265/70R19.5	6.75, 7.50, 8.25
275/80R22.5	7.50, 8.25
295/75R22.5	8.25, 9.00
315/80R22.5	9.00

Maintenance Intervals and Specifications

Lubricant and Sealer Specifications

Lubricant and Sealer Specifications

Component	Component Vendor / Lubrication Type	Viscosity / Ambient Temperature / Notes
Non-driving Front Axle		
Front Axle Wheel Bearing Oil	Eaton® / Dana® axle (generic)	75W : -40°F to - 15°F (-40°C to -26°C) 75W-80: -40°F to 80°F (-40°C to 27°C) 75W-90: -40°F to 100°F (-40°C to 38°C) 75W-140: -40°F and above (-40°C and above) 80W-90: -15°F to 100°F (-26°C to 38°C) 80W-140: -15°F and above (-26°C and above) 85W-140: -12°C and above (10°F and above)
	Eaton® / Dana® axle: multipurpose Extreme Pressure (EP) gear lube of API GL-5 quality meeting MIL-PRF-2105E specs including *synthetic lubricants. * Do not mix conventional lube with synthetic lube.	75W : -40°F to 32°F (-40°C to 0°C) 75W-90: -40°F to 100°F (-40°C to 38°C) 75W-140: -40°F and above (-40°C and above) 80W : -15°F to 70°F(-26°C to 21°C) 80W-140: -15°F and above (-26°C and above) 90W : 10°F to 100°F (-12°C to 38°C) 85W-40: 10°F and above (-12°C and above) 140W : 40°F and above (4°C and above)

Lubricant and Sealer Specifications (cont.)

Component	Component Vendor / Lubrication Type	Viscosity / Ambient Temperature / Notes
Front Axle Wheel Bearing Oil – (Cont)	Meritor: Synthetic from factory with Cognis Emgard® 75W-90 will have a tag attached to fill plug that reads as follows: Filled with synthetic lube. Do not mix.	75W-90
	Meritor: Petroleum 0-76-A Hypoid Gear Oil 0-76-D Hypoid Gear Oil 0-76-E Hypoid Gear Oil 0-76-J Hypoid Gear Oil Petroleum oil: engine oil API-CF2	85W-140: 10°F and above (-12°C and above) 80W-90: -15°F and above (-26°C and above) 75W-90: -40°F and above (-40°C and above) 75W :-40°F to 36°F (-40°C to 2°C) SAE 40 or 50:10°F and above (-12°C and above) SAE 30: -15°F and above (-26°C and above)
Front Axle Wheel Bearing Grease, Tie Rod Ends, Drag Link, Kingpin and Bushing	Eaton® / Dana® axle, Meritor axle: Fleetrite® NLGI # 2 Lithium Complex Based Molybdenum Grease P/N 991044C2 or equivalent GC / LB NLGI #2 multi-purpose lithium complex grease	NOTE: Eaton® / Dana® and Meritor Easy Steer axles: With chassis load on axle, force grease through thrust bearings; then with axle lifted clear of floor, force grease between kingpin and bushing surfaces.
Brakes		
Brake Fluid	DOT 3 Brake fluid	
Body Components		
Emergency Window Slides	WD-40 Specialist Dirt & Dust Resistant Dry Lube PTFE Spray or equivalent PTFE lubricant	

Maintenance Intervals and Specifications

Lubricant and Sealer Specifications (cont.)

Component	Component Vendor / Lubrication Type	Viscosity / Ambient Temperature / Notes
Engine		
Engine Lubricating Oil	Refer to Engine Operation and Maintenance Manual	
Engine Lubricating Oil – Cummins® B6.7 Engines only	NOTE: For vehicles equipped with Cummins® B6.7 engines, refer to Cummins QuickServe® Online, your Cummins Engine Operation Manual, or contact a certified Cummins repair location for specific engine maintenance intervals, capacities, and instructions.	
Electrical		
Terminals –Lubricant Sealing Grease	Fleetrite® 472141-C1	
Connectors –Dielectric Grease	NYOGEL® 760 G	
Steering		
Strg. Gear Ross TAS – Output Seal –Lubricate	Fleetrite® Lithium Complex Based Moly grease P/N 991044C2 or equivalent GC / LB NLGI #2 Multi-purpose Lithium Complex grease	
Strg. Intermediate Shaft U –Joints / Slip Joint –Lubricate	Fleetrite® NLGI #2 Lithium Complex Based Moly grease P/N 991044C2 or equivalent GC / LB NLGI #2 Multi-purpose Lithium Complex grease	

Lubricant and Sealer Specifications (cont.)

Component	Component Vendor / Lubrication Type	Viscosity / Ambient Temperature / Notes
Approved (Power Steering Fluids)		
ATF Fluid (Approved for Use in Power Steering System)	Fleetrite® P/N FLTPSDX3Q (MPAPS B-6822 Specification) or Equivalent (Must Meet TES 389 / Dexron III Specification)	-40°F to 92°F (-40°C to 35°C)
Power Steering Fluid	Fleetrite® Power Steering Fluid P/N FLTPSF32 (MPAPS B-6811 Specification)	-24°F to 90°F (-33°C to 32°C)
Engine Oil (Approved for Use in Power Steering System)	Fleetrite® P/N FLTL15W40G (MPAPS B-21 Specification) or Equivalent API CK-4 15W-40 Motor Oil	18°F to 108°F (-10°C to 43°C)

NOTE: The power steering system is filled with ATF fluid at the factory.



CAUTION

To prevent component / system / property damage, **ONLY** use fluid types listed.

NOTE: Certain fluid types may be better suited for use in your vehicle, dependent on geographic location and temperature. It is recommended to use the Ambient Temperatures listed above to determine what fluid best fits the application of the user's fleet or vehicle.

NOTE: The same type of approved power steering fluid that is present in the system must be used when topping off. When switching to another approved power steering fluid type, the power steering system must be drained and flushed prior to refill.

Maintenance Intervals and Specifications

Lubricant and Sealer Specifications (cont.)

Component	Component Vendor / Lubrication Type	Viscosity / Ambient Temperature / Notes
Drive Shaft		
U-Joint –Lubricate	Fleetrite® NLGI #2 Lithium Complex Based Moly grease P/N 991044C2 or equivalent GC / LB NLGI #2 Multi-purpose Lithium Complex grease	
Clutch		
Release Bearing / Shafts / Fork –Lubricate	Fleetrite® NLGI #2 Lithium Complex Based Moly grease P/N 991044C2 or equivalent GC / LB NLGI #2 Multi-purpose Lithium Complex grease	
Cooling System		
Coolant	Refer to Engine Operation and Maintenance Manual	

Lubricant and Sealer Specifications (cont.)

Component	Component Vendor / Lubrication Type	Viscosity / Ambient Temperature / Notes
Transmission		
All Eaton Transmissions	Synthetic Transmission Oil: Emgard® MTF 7000 meeting Eaton PS-386	All temperatures
Eaton® / Dana® (Non –Synchronized) - Fill / Change (Lubricants are listed in order of preference)	Mineral Gear Oil API-GL-1 (Rust and Oxidation Inhibited) Fleetrite® P/N 991061C1 Petroleum Oil: Engine Oil API-CJ, or CI	SAE 90: Above 0°F (-18°C) SAE 80: Below 0°F (-18°C) SAE 50: Above 0°F (-18°C) SAE 40: Below 0°F (-18°C)
* EP Gear Oils are not recommended for use in manual transmissions.		
	Synthetic Oil: Synthetic SAE 50 Manual Transmission Oil Meeting API MT-1 Fleetrite® P/N 991884C1	SAE 50: All temperatures
Eaton® Fuller® UltraShift®	WetClutch (Synthetic): Castrol® TranSynd® or TES-295 Gear Box: EmGard® 2979	All temperatures SAE 50: All temperatures
Eaton® / Dana® (Synchronized) –Fill / Change (Lubricants are listed in order of preference)	Mineral Gear Oil API-GL-1 (Rust and Oxidation Inhibited) Fleetrite® P/N 991061C1 Petroleum Oil: Engine Oil API-CJ, or CI	SAE 90: Above 10°F (-12°C) SAE 80: Below 10°F (-12°C) SAE 50: Above 10°F (-12°C) SAE 40: Below 10°F (-12°C)
Eaton® / Dana® (Synchronized) – Fill / Change	Synthetic Oil: Synthetic SAE 50 Manual Transmission Oil Meeting API MT-1 Fleetrite® P/N 991884C1	SAE 50: All temperatures
	Synthetic Oil: API MT-1*	SAE 50: All temperatures

Maintenance Intervals and Specifications

Lubricant and Sealer Specifications (cont.)

Component	Component Vendor / Lubrication Type	Viscosity / Ambient Temperature / Notes
	* Do not use multi-weight and GL-5 EP gear oils because they may cause transmission failure or damage.	
Allison –Synthetic Automatic Transmission Fluid (ATF) Fill / Change (optimal - recommended)	Fleetrite® Synthetic ATF (P/N: FATF27101Q), or Allison / Castrol® TRANSYND® synthetic ATF, or fluids meeting AllisonTES 295 specification. Approved Synthetic ATF Supplier Web site: http://www.allisontransmission.com/home/	All temperatures. Recommended for highest transmission durability and lowest maintenance costs.
Allison –Conventional Automatic Transmission Fluid (ATF) Fill / Change	Meets the requirements for Allison TES 389 specification. Approved Conventional ATF Supplier Web site: http://www.allisontransmission.com/home/	Below -13°F (-25°C) preheat is required
Rear Axle		
Single speed	Gear oil meeting MIL-PRF-2105E, API MT-1, GL-5	75W : -40°F to - 15°F (-40°C to -26°C) 75W-80: -40°F to 80°F (-40°C to 27°C) 75W-90: -40°F to 100°F (-40°C to 38°C) 75W-140: -40°F and above (-40°C and above) 80W-90: -15°F to 100°F (-26°C to 38°C) 80W-140: -15°F and above (-26°C and above) 85W-140: 10°F and above (-12°C and above)

Lubricant and Sealer Specifications (cont.)

Component	Component Vendor / Lubrication Type	Viscosity / Ambient Temperature / Notes
Single speed – Continued.	International® axle: multipurpose EP gear lube of API GL-5 quality meeting MIL-PRF-2105E or SAE J2360 specs including synthetic lubricants.	75W : -40°F to 32°F (-40°C to 0°C) 75W-90: -40°F to 100°F (-40°C to 38°C) 75W-140: -40°F and above (-40°C and above) 80W : -15°F to 70°F (-26°C to 21°C) 80W-140: -15°F and above (-26°C and above) 90W : 10°F to 100°F (-12°C to 38°C) 85W-140: 10°F and above (-12°C and above) 140W : 40°F and above (4°C and above)
	Meritor:Synthetic from factory with Cognis Emgard® 75W-90 will have a tag attached to fill plug that reads as follows: Filled with synthetic lube. Do Not Mix.	
	Meritor petroleum: 0-76-A Hypoid Gear Oil 0-76-B Hypoid Gear Oil 0-76-D Hypoid Gear Oil 0-76-E Hypoid Gear Oil 0-76-L Hypoid Gear Oil	GL-5, SAE 85W-140: Above 10°F (-12°C) GL-5, SAE 85W-140: Above -15°F (-26°C) GL-5, SAE 80W-90: Above -15°F (-26°C) GL-5, SAE 75W Max outside temp.35°F (2°C): Above -40°C (-40°F) GL-5, SAE 75W-140: Above -40°F (-40°C)

Maintenance Intervals and Specifications

Torque Specification Charts

Disc Wheels Torque Chart

Stud Size	Nut Size	Specified Torque	
		lb-ft	N•m
22 mm	Flange Nut – 33 mm Across Flats	450 - 500	610 - 678
NOTE: Do not use lubrication on dry threads. Where excessive corrosion exists, a light coat of lubricant on first three threads of stud bolt is permitted. Keep lubricant away from:			
<ul style="list-style-type: none">• Hex nut• Flange nut washer surface and flat on disc wheel.			

Steering Column Bolts Torque Chart

Bolt Type	Specified Torque	
	lb-ft	N•m
7/16-20	70 - 75	95 - 102

Axle U-Bolt Nut Torque Chart

Feature Code	Rear Suspension Capacity and Type	Torque	
		lb-ft	N•m
14SBK	19,800-lb Capacity, 2 Stage Vari-Rate	260 - 300	353 - 407
14SBW	21,000-lb Capacity, V-Rate, with 4,500-lb Auxiliary Spring	260 - 300	353 - 407
14TBG	12,000-lb Capacity, International Air Suspension (IROS) for axles 14ADN, 14ADP, 14AJC, 14AJE, 14ATP, and 14ATR.	260 - 300	353 - 407
	12,000-lb Capacity, International Air Suspension (IROS) for all other axles.	370 - 400	502 - 542
14TBH	15,500-lb Capacity, International Air Suspension (IROS) for axles 14ADN, 14ADP, 14AJC, 14AJE, 14ATP, and 14ATR.	260 - 300	353 - 407
	15,500-lb Capacity, International Air Suspension (IROS) for all other axles.	370 - 400	502 - 542
14TBT	23,000-lb Capacity, International Air Suspension (IROS) for axles 14ADN, 14ADP, 14AJC, 14AJE, 14ATP, and 14ATR.	260 - 300	353 - 407
	23,000-lb Capacity, International Air Suspension (IROS) for all other axles.	260 - 300	353 - 407
14VAB	13,500-lb Capacity, RR, Springs, Vari-Rate, with 4,500-lb Auxiliary Rubber Spring	260 - 300	353 - 407
14VAC	15,500-lb Capacity, RR, Springs, Vari-Rate, with 4,500-lb Auxiliary Rubber Spring	260 - 300	353 - 407
14VAD	18,500-lb Capacity, RR, Springs, Vari-Rate, with 4,500-lb Auxiliary Rubber Spring	260 - 300	353 - 407
14VAM	10,000-lb Capacity, RR, Steel Springs	260 - 300	353 - 407
14VAN	9,000-lb Capacity, RR, Steel Springs	260 - 300	353 - 407
NOTE: For all other vendor supplied suspensions, refer to vendor's Web site for proper torque specifications.			
3ADA	8,000-lb Capacity, Parabolic Taper Leaf	260 - 300	353 - 407
3ADB	10,000-lb Capacity, Parabolic Taper Leaf	260 - 300	353 - 407
3AGZ	7,000-lb Capacity, Parabolic Taper Leaf	260 - 300	353 - 407

Maintenance Intervals and Specifications

Wiper Arm Torque Chart

	Specified Torque	
	lb-ft	N•m
Wiper Pivot M20 Hex Nut	21	28

Seat Base Bolts

	Specified Torque	
	lb-ft	N•m
All Seat Base Bolts	16 to 20	21.7 to 27

Filter List

Filter part numbers and / or specifications may change during the life-cycle of this vehicle. Current information on the appropriate chassis and engine filters for your vehicle can be obtained by contacting your local International dealer parts department. If you need assistance finding a local International dealer, use the Dealer Locator icon at www.icbus.com.

SECTION 14 — CUSTOMER ASSISTANCE

Service Information

The continued premium performance of this IC Bus® vehicle can best be ensured through proper servicing. This can be accomplished in several ways.

IC Bus® Dealers ... Your local IC Bus® dealer provides an excellent resource – through his knowledgeable, experienced, and well equipped service staff – to handle all your maintenance, repair, and replacement work.

Service Publications ... Those persons who are properly trained technicians with the facilities, equipment, tools, safety instructions and know-how to properly and safely service a bus can purchase the appropriate service manual sections applicable to specific vehicle components or areas of this vehicle. Engine diagnostic manuals and engine service manuals for all current Navistar engines are also available to these trained persons for purchase. Information on the purchase of available service publications for this vehicle can be found on the www.icbus.com or www.internationaltrucks.com Web site, or by contacting your local IC Bus or International Truck Dealer.

These resources are also available via the internet, by an annual subscription to the **International® Service PortalSM Web site**, or via **the OnCommand® Service Information USB**. For Information on the International Service Portal website's content, availability, and fee structure, contact your local

International Truck Dealer or, in the case of a National Account, your International Fleet Service Manager. The OnCommand Service Information USB contains International® and IC Bus® branded truck, engine, and bus information including service and diagnostic manuals, troubleshooting guides, circuit diagram manuals, and new vehicle processing manuals.

NOTE: When ordering any service information, be sure to provide your vehicle's model designation, build date, engine series, and the Vehicle Identification Number (VIN).

Navistar, Inc., Warranty Program

Standard Warranty • Optional Service Contracts • Custom Service Contracts • Performance PM®

The Navistar Warranty Program provides IC Bus customers with a better choice when it comes to Standard Warranty and Service Contract Coverage. The **Standard Warranty** is the first tier of the Navistar. Warranty Program. It provides the foundation for all extended coverages.

Vehicle Coverage, Towing, Engine and Engine Electronics, Major Component, and Pre-Packaged System Component protection can be obtained under the Navistar. Warranty Program through **Optional Service Contracts**.

Customer Assistance

Custom Service Contracts, the most flexible aspect of the Navistar Warranty Program, can provide extended protection that is specifically tailored to meet each customer's specific requirements.

Finally, through **Performance PM®**, customers can obtain a comprehensive preventative maintenance program designed to ensure consistency in pricing and the level of service received.

ADVANTAGES of Navistar, Inc. Warranties

- Extends warranty protection to specified length and component coverage to suit individual needs
- Honored at all IC Bus® dealer locations in North America
- Stabilized and predictable maintenance costs
- Increased owner confidence and peace of mind
- Improved resale value on your vehicle – International Truck Warranties may be transferable for a nominal fee. Contact the Service Contract Center 1-800-336-4500 option 5 for transferability
- Most coverage is 100% parts and labor with **NO DEDUCTIBLES**
- Customized warranty programs are offered to suit your needs - your specification - your vocation
- Optional Service Contracts, Custom Service Contracts, and Performance PM, designed to ensure the lowest possible cost of ownership, are also available

- Published Service Contracts Performance PM® Service, designed to ensure the lowest possible cost of ownership, are also available.
- Optional Service Contracts have been pre-packaged to fit most common applications.

HOW TO OBTAIN Navistar, Inc. Warranties

- **Standard Warranty:** Your new IC Bus® vehicle is automatically registered in the Navistar Warranty System at the time of delivery. No further action, on your part, is required.
- **Optional Service Contracts, Custom Service Contracts, or Performance PM®:** These programs are sold exclusively through your IC Bus® dealer. You have 365 days and up to a maximum of 100,000 miles (160,000 km), from DTU (delivery to end user), to purchase an extended warranty on your vehicle. The vehicle must also have coverage remaining under the Standard Warranty. For extended warranty purchases between, 181 through 365 days from DTU and < 100,000 miles (160,000 km) an additional fee will be assessed. If you would like the predictable cost of ownership and peace of mind provided by the Navistar Warranty Program, please contact your IC Bus® dealer today!

SECTION 15 — INDEX

Numerics/Symbols

39-Inch Flex Seat.....104

A

ABS / Plastic.....184

ABS Self-Check.....153

Accessory Feed Connections.....202

Activation.....78

Additional Components Covered.....8

Additional Unsafe Practices.....129

Adjustable Tilt Steering Column.....62

Adjusting the Length of the Tether.....98

After the Engine Starts.....127

Air Brakes.....148, 195

 Air Disc Brakes (0004JBZ, 0004JCC, 0004WEY,
 0004WEZ).....148

 Air Dryer.....197

 Air Dryer Desiccant Replacement.....197

 Air Dryer Heater.....198

 Air Dryer Purge Valve.....198

 Air Reservoir / Tanks Moisture Draining.....198

 Brake Inspection and Adjustment.....195

 Parking Brake Indicator Light.....150

 Using Air Brakes.....149

 Using the Air Parking Brake.....149

Air Cleaner Element Service.....204

Air Conditioner Refrigerant.....243

 Axle-Rear Table.....243

Air Conditioning.....121

A (CONT.)

Air Disc Brakes (0004JBZ, 0004JCC, 0004WEY,
0004WEZ).....148

Air Dryer.....197

Air Dryer Desiccant Replacement.....197

Air Dryer Heater.....198

Air Dryer Purge Valve.....198

Air Induction System.....204

Air Intake System.....215

Air Reservoir / Tanks Moisture Draining.....198

Air Restriction Gauge Service.....206

 High Restriction Reading Table.....207

 No Restriction Reading Table.....207

 Troubleshooting.....207

Air-Actuated Door.....81

Air-Operated Passenger Door Adjustments.....191

 Door Opening and Closing Speed Adjustment Points.....191

 Closing Speed Adjustment.....192

 Opening Speed Adjustment.....192

 Pressure Regulator Adjustment.....191

 Electrically Actuated Entrance Door Adjustment.....192

Allison Generation IV Push-Button Shift Selector.....163

Allison Generation IV T-Bar Gearshift Control.....162

Allison Transmission Mechanical Lever Shifters.....161

Alternator–Starter–Battery Test.....202

Antilock Braking System (ABS).....152

Antilock Driving Tips.....153

Approved Tire and Wheel Combinations Table.....245

Assistance Guide.....2

Audible Alarms Table.....53

Index

A (CONT.)

Audible Warning Buzzer.....	84
Automatic Headlights.....	75
Automatic Transmission Operating Temperatures.....	168
Automatic Transmission Operation.....	160
Allison Generation IV Push-Button Shift Selector.....	163
Allison Generation IV T-Bar Gearshift Control.....	162
Allison Transmission Mechanical Lever Shifters.....	161
Automatic Transmission Operating Temperatures.....	168
Backup Alarms.....	167
Eaton® Procision™ Transmission.....	164
Economy Mode.....	167
Parking the Bus With Transmission Shift / Wheelchair Lift Interlocks.....	166
Wheelchair Lift Extension Operation.....	166
Parking the Vehicle.....	164
Retracting and Stowing Operation.....	167
Standard Allison 1000 PTS Transmission.....	160
Starting Bus in Motion.....	166
Starting Bus in Motion With Transmission Shift / Wheelchair Lift Interlocks.....	167
Automatic Transmission Starter Interlock.....	126
Auxiliary Fuel-Fired Heater System (Optional).....	118
Description.....	119
Heater Control Switch.....	120
Heating Mode.....	120
Introduction.....	118
Operation.....	119
Switching-Off Sequence.....	121
Auxiliary Fuel-Fired Heater System Table.....	21
Auxiliary Heaters.....	118
Axle U-Bolt Nut Torque Chart Table.....	255

A (CONT.)

Axle-Rear Table.....	243
Axles.....	192
Body.....	194
Front Axle – Alignment.....	193
Front Axle – Inspection and Lubrication.....	192
Front Axle – Normal Maintenance.....	193
Rear Axle – Inspection and Lubrication.....	194

B

Backup Alarms.....	167
Basic Functions of Steering Wheel Controls.....	60
Bendix® Wingman® Advanced™ Collision Warning System... ..	155
Bendix® Wingman® Fusion™ System.....	157
Body.....	194, 215
Body Fluid Cleanup Kit.....	170
Body Fuse / Circuit Breaker Panel.....	174
Power Relays Table.....	177
Brake Fluid Level (SmartTrac™ System).....	200
Brake Inspection and Adjustment.....	195, 199
Brake Lines, Hoses, and Fittings.....	199
Brakes.....	194
ABS Self-Check.....	153
Air Brakes.....	148, 195
Air Disc Brakes (0004JBZ, 0004JCC, 0004WEY, 0004WEZ).....	148
Air Dryer.....	197
Air Dryer Desiccant Replacement.....	197
Air Dryer Heater.....	198
Air Dryer Purge Valve.....	198
Air Reservoir / Tanks Moisture Draining.....	198
Brake Inspection and Adjustment.....	195

B (CONT.)

Brakes (cont.)

Parking Brake Indicator Light	
Air Brake Gauge.....	150
Using Air Brakes.....	149
Using the Air Parking Brake.....	149
Antilock Braking System (ABS).....	152
Antilock Driving Tips.....	153
Chassis Inspection	
Parking Brake Burnish Procedure	
Parking Brake Burnish Procedure.....	201
Downhill Operation.....	144
Warning Indicators.....	144
General Information.....	194
Hydraulic Brakes.....	200
Brake Fluid Level (SmartTrac™ System).....	200
Driveline Parking Brake.....	201
SmartTrac™ Hydraulic Brakes - Fluid Precautions.....	201
Manual Foot Operated Parking Brake System with Hydraulic Brakes.....	146
To Manually Apply the Parking Brake.....	147
To Manually Release The Parking Brake.....	147
Parking Brake / Wheelchair Lift Interlock and Alarm.....	151
Parking Brake / Wheelchair Lift (Optional) Alarm.....	151
Parking Brake / Wheelchair Lift Interlock–Retracting and Stowing Operation.....	151
Wheelchair Lift Extension Operation.....	151
Pedal Adjustment Switch (If Equipped).....	154
Manual Pedal Adjustment.....	154
SmartTrac™ Hydraulic Brake Booster System (If Equipped).....	145
SmartTrac™ Hydraulic Brakes (If Equipped).....	199
Brake Inspection and Adjustment.....	199

B (CONT.)

Brakes (cont.)

Brake Lines, Hoses, and Fittings.....	199
Fluid Precautions.....	199
Split-System Feature.....	146
Brakes Table.....	15
Buckling Up.....	101
BUS-SCAN® 100 System.....	86
Unloading Students With Engine OFF.....	87

C

Canadian Registered Vehicles.....	5
Care of Seat Belts.....	98
Inspection of Seat Belts.....	99
Cautions / Warnings / Notes.....	1
CE Bus Front View.....	10
CE Bus Left View.....	12
CE Bus Rear View.....	10
CE Bus Right View.....	11
CE White Integrated Child Restraint Seats (Optional).....	107
Certified Clean Idle.....	128
Chassis Fuse / Circuit Breaker Chart.....	171
Chassis Inspection.....	201
Chassis Lubrication.....	189
Chassis-Mounted Charge Air Cooler and Radiator Core Inspection and Cleaning.....	208
Checking Inflation.....	224
Child Restraint Anchorage Systems (Optional).....	109
Location and Use of Lower Latch Anchors.....	110
Circulation Fans.....	122
Cleaning.....	222
Closing Speed Adjustment.....	192
Cold Weather Operation.....	142

Index

C (CONT.)

<i>Cold Weather Operation (cont.)</i>	
Engine Idling.....	143
Instructions.....	142
Winter Fronts.....	143
Compass Declination Zone Set Procedure.....	47
Compass Directional Calibration Procedure.....	50
Component Code Numbers.....	2
Coolant and Optional Coolant Filter.....	211
Coolant Concentration / Freeze Point.....	212
Cooling System.....	208
Cooling System Refill Capacities.....	243
Crossing Arm Cleaning.....	186
Crossing Gate.....	84
Cruise Control.....	60, 71
Basic Functions of Steering Wheel Controls.....	60
Mobile Variable Speed Control (12VXV).....	62
Operation.....	71
Operational Procedures.....	60
Stationary Pre-Set Speed Control (12VXU).....	61
Stationary Variable Speed Control (12VXT).....	61
Throttle.....	61
Cushion Release Latch.....	112

D

Deactivation.....	78
DEF Contamination or SCR System Fault.....	134
DEF Tank.....	132
DEF Tank Filling.....	221
Defrost Operating Instructions.....	118
Description.....	119
Diesel Exhaust Fluid.....	131
Diesel Exhaust Fluid (DEF) Storage.....	4

D (CONT.)

Diesel Exhaust Fluid Tank.....	244
Diesel Particulate Filter (DPF) Regeneration Table Table.....	139
Direct Drive Warning Indicators.....	29
Disc Wheels Torque Chart Table.....	254
Door Opening / Closing.....	79
Opening / Closing.....	79
Three-Position Door Switch.....	80
Two-Position Door Switch.....	79
Door Opening and Closing Speed Adjustment Points.....	191
Closing Speed Adjustment.....	192
Opening Speed Adjustment.....	192
Pressure Regulator Adjustment.....	191
Downhill Operation.....	144
Warning Indicators.....	144
Drive Shaft.....	218
Driveline Parking Brake.....	201
Driver Assist Systems.....	155
Driver Heater.....	117
Driver Seat Adjustment.....	93
Seat Height Adjustment.....	94
Driver Seat Belts.....	96
Driver Visual Warning Lights and Indicators.....	84
Driver's Adjustable Lap and Shoulder (Three-Point) Belt.....	96
Dual Tires Matching.....	226
Dual Tires Mixing.....	226

E

Eaton® Procision™ Transmission.....	164
Economy Mode.....	167
Eight-Lamp AMBER and RED Warning Lights.....	81
Electric-Actuated Door.....	80

E (CONT.)

Electrical.....202
 Accessory Feed Connections.....202
 Alternator–Starter–Battery Test.....202
 Terminal Inspection–Cleaning–Corrosion Protection.....202
 Electrically Actuated Entrance Door Adjustment.....192
 Electronic Safety Messages.....81
 Emergency Door.....89
 Emergency Equipment (Recommended On-Board).....169
 Body Fluid Cleanup Kit.....170
 Fire Extinguisher.....169
 First Aid Kit.....170
 Reflective Triangle.....171
 Emergency Exit Windows.....89
 Horizontal Emergency Exit Window.....89
 Vertical Emergency Exit Window.....90
 Emergency Exits.....88
 Emergency Door.....89
 Emergency Exit Windows.....89
 Horizontal Emergency Exit Window.....89
 Vertical Emergency Exit Window.....90
 Roof Vent / Hatch.....91
 Emergency Exits and Equipment Table.....21
 Emergency Starting Using Jumper Cables.....179
 Emission Control Systems.....7
 HD-OBd Foreword.....7
 Supplemental Federal Emission Control System Warranty...7
 Additional Components Covered.....8
 GHG Emission Control System Warranty Period.....7
 Supplemental Federal Emission Control System
 Maintenance, Repair, and Replacement.....8
 Engine.....203

E (CONT.)

Engine (cont.)

Air Cleaner Element Service.....204
 Air Induction System.....204
 Air Restriction Gauge Service206
 Troubleshooting.....207
 Chassis-Mounted Charge Air Cooler and Radiator Core
 Inspection and Cleaning.....208
 Cooling System.....208
 Engine Fluids and Contaminated Material.....203
 Frame and Optional Tow Hooks.....213
 Fuel System.....214
 Fuel Tank Draining and Cleaning.....214
 General.....203
 Gravity-Fill Coolant Method.....208
 Coolant and Optional Coolant Filter.....211
 Coolant Concentration / Freeze Point.....212
 Fan Clutch.....212
 Heater and Coolant Hose Inspection and Replacement
 Guide.....212
 Heater System.....215
 Integrated Air Conditioning (IC Air) System.....215
 Scheduled Maintenance.....204
 Engine and Exhaust Brake Systems Operation.....130
 Engine Brake, Exhaust Brake, or Retarder (Optional).....130
 Engine and Exhaust Brake Systems Operation.....130
 Operational Modes.....131
 Engine Compartment Fluid Check Points.....190
 Engine Crankcase.....244
 Power Steering Systems Table.....244
 Transmission Table.....244
 Engine Features.....127

E (CONT.)

<i>Engine Features (cont.)</i>	
Certified Clean Idle.....	128
HD-OBD Overview.....	128
Self Diagnostics.....	128
Engine Fluids and Contaminated Material.....	203
Engine Idling.....	143
Engine Noise Shields / Blankets.....	216
Entrance Door Lock (If Equipped).....	92
Exhaust Aftertreatment.....	131
Exhaust Diesel Particulate Filter Regeneration.....	138
Parked Regeneration Procedure.....	141
Regeneration Inhibit Switch.....	141
Three-Position Regeneration Inhibit Switch.....	142
Two-Position Regeneration Inhibit Switch.....	142
Selective Catalytic Reduction System (If Equipped).....	131
DEF Contamination or SCR System Fault.....	134
DEF Tank.....	132
Diesel Exhaust Fluid.....	131
Introduction.....	131
Low DEF Level.....	132
Exhaust Diesel Particulate Filter (DPF).....	222
Cleaning.....	222
Regeneration.....	222
Transmission.....	222
Transmission Fluid Level.....	222
Exhaust Diesel Particulate Filter Regeneration.....	138
Diesel Particulate Filter (DPF) Regeneration Table	
Table.....	139
Parked Regeneration Procedure.....	141
Regeneration Inhibit Switch.....	141
Three-Position Regeneration Inhibit Switch.....	142

E (CONT.)

<i>Exhaust Diesel Particulate Filter Regeneration (cont.)</i>	
Two-Position Regeneration Inhibit Switch.....	142
Exhaust System.....	216
Exterior.....	185
Crossing Arm Cleaning.....	186
Waxing or Polishing Vehicles.....	186
Exterior Checks Table.....	13
Exterior Lamp Check.....	78
Activation.....	78
Deactivation.....	78
Function.....	78
Switch Location.....	78
Exterior Noise Emissions.....	5

F

Fan Clutch.....	212
Filter List.....	256
Fire Extinguisher.....	169
First Aid Kit.....	170
Flashing Stop Arm.....	83
Flooring.....	185
Fluid Precautions.....	199
Frame and Optional Tow Hooks.....	213
Front / Rear Suspension Table.....	15
Front Axle – Alignment.....	193
Front Axle – Inspection and Lubrication.....	192
Front Axle – Normal Maintenance.....	193
Fuel.....	128
Additional Unsafe Practices.....	129
Engine Brake, Exhaust Brake, or Retarder (Optional).....	130
Engine and Exhaust Brake Systems Operation.....	130

F (CONT.)

Fuel (cont.)

- Operational Modes.....131
- Fuel and Lubricant Additives.....129
- Fueling Precautions.....130
- Fueling Procedures.....129
- Hazards of Diesel Fuel / Gasoline Blends.....128
- Reserve Fuel.....130
- Restarting After Running Out of Fuel.....130
- Ultra-Low Sulfur Diesel Fuel Requirements.....128
- Unacceptable Fuel Blends.....128
- Fuel and Lubricant Additives.....129
- Fuel System.....214
 - Fuel Tank Draining and Cleaning.....214
- Fuel Tank Draining and Cleaning.....214
- Fueling Precautions.....130
- Fueling Procedures.....129
- Function.....78
- Fuse / Circuit Breaker Charts.....171
 - Body Fuse / Circuit Breaker Panel.....174
 - Emergency Starting Using Jumper Cables.....179
 - Reflective Triangle
 - Chassis Fuse / Circuit Breaker Chart.....171
 - Tilt Hood.....178
 - Lowering the Hood.....179
 - Raising the Hood.....178

G

- General.....203, 218
- General Cleaning, All Surface Types.....183
- General Information.....194
- GHG Emission Control System Warranty Period.....7
- Glass.....184

G (CONT.)

- Gravity-Fill Coolant Method.....208
 - Coolant and Optional Coolant Filter.....211
 - Coolant Concentration / Freeze Point.....212
 - Fan Clutch.....212

H

- Hazard Warning Light Switch.....76
- Hazard Warning Switch.....169
- Hazards of Diesel Fuel / Gasoline Blends.....128
- HD-OBD Foreword.....7
- HD-OBD Overview.....128
- Headlight Switch.....75
- Headlight Switch and Panel Lighting Control.....75
 - Automatic Headlights.....75
 - Headlight Switch.....75
 - Panel Lighting Control.....75
- Heater and Coolant Hose Inspection and Replacement Guide.....212
- Heater Booster Pump.....122
- Heater Control Switch.....120
- Heater Cutoff Valve.....123
- Heater System.....117, 215
 - Auxiliary Heaters.....118
 - Driver Heater.....117
- Heating Mode.....120
- HIGH / LOW Beam.....77
- High Restriction Reading Table.....207
- Horizontal Emergency Exit Window.....89
- Horn.....59
- Hot Weather Operation.....143
- Hub-Piloted Wheel Installation Procedures.....229

H (CONT.)

Hydraulic Brakes.....	200
Brake Fluid Level (SmartTrac™ System).....	200
Driveline Parking Brake.....	201
SmartTrac™ Hydraulic Brakes - Fluid Precautions.....	201

I

IMMI® Seats Tether Installation.....	111
Installing Tether.....	111
Location and Use of Tether Anchors (BTI Bus Seats).....	111
Location and Use of Tether Anchors (SafeGuard® XChange Bus Seats).....	111
Indiana Mills and Manufacturing Inc. (IMMI®) Integrated Child Restraint Seats (Optional).....	105
Indicators about DEF Quality Problem (For Vehicles Equipped with Cummins® B Engines) Table.....	135
Indicators about Low DEF Level (For Vehicles Equipped with Cummins® B Engines) Table.....	133
Inspection.....	225
Inspection Check Lists.....	13
Underhood and Fluid Checks.....	16
Inspection of Seat Belts.....	99
Installation.....	232
Installing Tether.....	111
Instructions.....	142
Instructions for Proper Maintenance.....	215
Instrument Panel Gauge Audible Alarms.....	53
Audible Alarms Table.....	53
Instrument Panel Gauge Cluster.....	23, 28
Direct Drive Warning Indicators.....	29
Instrument Panel Gauge Audible Alarms.....	53
Instrument Panel Gauge Cluster.....	28
Integral Digital Display.....	30

I (CONT.)

<i>Instrument Panel Gauge Cluster (cont.)</i>	
Integral Digital Display Detailed Information.....	33
Quadrant 2: Text and Warning Messages.....	39
Warning Messages.....	45
Optional Instrument Panel Gauge Cluster Compass Calibration Procedure.....	46
Compass Declination Zone Set Procedure.....	47
Compass Directional Calibration Procedure.....	50
Outside Temperature and Compass Displays (Optional).....	45
Outside Temperature Reading.....	46
Quadrant 4: Transmission Gear Displays.....	46
User Switches.....	52
Warning Indicators.....	25
Integral Digital Display.....	30
Integral Digital Display Table.....	31
Integral Digital Display Detailed Information.....	33
Quadrant 1: Informational Displays Table.....	33
Quadrant 2: Text and Warning Messages.....	39
Quadrant 2: Text and Warning Messages Table.....	39
Warning Message Table.....	45
Warning Messages.....	45
Integral Digital Display Table.....	31
Integrated Air Conditioning (IC Air) System.....	215
Integrated Air Conditioning System (IC Air).....	121
Integrated Air Conditioning System (IC Air) Table.....	20
Integrated Child Restraint Seats (Optional).....	104
Indiana Mills and Manufacturing Inc. (IMMI®) Integrated Child Restraint Seats (Optional).....	105
Interior.....	184
Flooring.....	185
Interior Light Bar Cleaning.....	184
Upholstery Care.....	184

I (CONT.)

Interior (Dome) Lights.....75
 Interior Light Bar Cleaning.....184
 Interior Visual and Operational Checks Table.....18
 International® Ride Optimized Suspension (IROS) (If Equipped).....160
 Introduction.....9, 118, 131
 Brakes Table.....15
 CE Bus Front View.....10
 CE Bus Left View.....12
 CE Bus Rear View.....10
 CE Bus Right View.....11
 Exterior Checks Table.....13
 Front / Rear Suspension Table.....15
 Irregular Wear.....227

L

Lane Change.....77
 Left Console Switch Panel.....63
 Power Outlet.....66
 Rocker Switches and Their Functions.....63
 Line Set Ticket.....2
 Loads.....225
 Location and Use of Lower Latch Anchors.....110
 Location and Use of Tether Anchors (BTI Bus Seats).....111
 Location and Use of Tether Anchors (SafeGuard® XChange Bus Seats).....111
 Location of the Tether Anchor (Optional).....110
 Low DEF Level.....132
 Lowering the Hood.....179
 Lubricant and Sealer Specifications.....246
 Lubricant and Sealer Specifications Table.....246

L (CONT.)

Lubricant and Sealer Specifications Table.....246
 Lubrication and Maintenance Interval Chart Notes.....234
 Lubrication and Maintenance Interval Chart Symbols Key...234
 Lubrication and Maintenance Interval: Bus – CE (Diesel) Table.....234
 Lubrication Points.....219

M

Maintenance Guidelines.....187
 Maintenance Intervals.....233
 Lubrication and Maintenance Interval Chart Notes.....234
 Lubrication and Maintenance Interval Chart Symbols Key.....234
 Lubrication and Maintenance Interval: Bus – CE (Diesel) Table.....234
 Maintenance Record – Noise Control.....217
 Drive Shaft.....218
 Suspension (Air and Steel Springs).....218
 Manual Foot Operated Parking Brake System with Hydraulic Brakes.....146
 To Manually Apply the Parking Brake.....147
 To Manually Release The Parking Brake.....147
 Manual Pedal Adjustment.....154
 Mirror Adjustment.....72
 Mobile Variable Speed Control (12VXV).....62

N

Navistar, Inc., Warranty Program.....257
 No Restriction Reading Table.....207
 Noise Emissions – Maintenance, Use and Repair.....215
 Air Intake System.....215

Index

N (CONT.)

<i>Noise Emissions – Maintenance, Use and Repair (cont.)</i>	
Body.....	215
Engine Noise Shields / Blankets.....	216
Exhaust System.....	216
Instructions for Proper Maintenance.....	215
Noise Emissions Warranty.....	6

O

Opening / Closing.....	79
Opening Speed Adjustment.....	192
Opening the Entrance Door.....	80
Air-Actuated Door.....	81
Electric-Actuated Door.....	80
Opening the Entrance Door Manually.....	80
Opening the Entrance Door Manually.....	80
Operation.....	71, 119
Operational Modes.....	131
Operational Procedures.....	60
Optional Air Suspension Seat.....	95
Optional Instrument Panel Gauge Cluster Compass Calibration Procedure.....	46
Compass Declination Zone Set Procedure.....	47
Compass Directional Calibration Procedure.....	50
Optional Rocker Switches.....	82
Outside Temperature and Compass Displays (Optional).....	45
Quadrant 3: Display Messages Table.....	45
Outside Temperature Reading.....	46
Quadrant 4: Transmission Gear Displays.....	46
Quadrant 4: Transmission Gear Indications Table.....	46
Overview.....	55

P

Panel Lighting Control.....	75
Parked Regeneration Procedure.....	141
Parking Brake / Wheelchair Lift (Optional) Alarm.....	151
Parking Brake / Wheelchair Lift Interlock and Alarm.....	151
Parking Brake / Wheelchair Lift (Optional) Alarm.....	151
Parking Brake / Wheelchair Lift Interlock–Retracting and Stowing Operation.....	151
Wheelchair Lift Extension Operation.....	151
Parking Brake / Wheelchair Lift Interlock–Retracting and Stowing Operation.....	151
Parking Brake Indicator Light.....	150
Parking the Bus With Transmission Shift / Wheelchair Lift Interlocks.....	166
Wheelchair Lift Extension Operation.....	166
Parking the Vehicle.....	164
Passenger Seat Belts.....	100
CE White Integrated Child Restraint Seats (Optional).....	107
Child Restraint Anchorage Systems (Optional).....	109
Location and Use of Lower Latch Anchors.....	110
Cushion Release Latch.....	112
IMMI® Seats Tether Installation.....	111
Installing Tether.....	111
Location and Use of Tether Anchors (BTI Bus Seats).....	111
Location and Use of Tether Anchors (SafeGuard® XChange Bus Seats).....	111
Integrated Child Restraint Seats (Optional).....	104
Indiana Mills and Manufacturing Inc. (IMMI®) Integrated Child Restraint Seats (Optional).....	105
Location of the Tether Anchor (Optional).....	110
Passenger Three-Point Seat Belts (Optional).....	101
39-Inch Flex Seat.....	104

P (CONT.)

Passenger Seat Belts (cont.)

- Buckling Up.....101
- Unbuckling.....103
- Passenger Two-Point Seat Belt (Lap Belts).....101
- Passenger Three-Point Seat Belts (Optional).....101
- 39-Inch Flex Seat.....104
- Buckling Up.....101
- Unbuckling.....103
- Passenger Two-Point Seat Belt (Lap Belts).....101
- Pedal Adjustment Switch (If Equipped).....154
- Manual Pedal Adjustment.....154
- Post-Trip Inspection (No Student Left Behind).....85
- Snooze Mode.....86
- System Activation.....85
- System Deactivation.....85
- System Function.....85
- System Purpose.....85
- Power Outlet.....66
- Power Relays Table.....173, 177
- Power Steering.....220
- Power Steering Systems Table.....244
- Pre-Trip and Post-Trip Inspections.....189
- Preface.....1, 187
- Pressure Regulator Adjustment.....191

Q

- Quadrant 1: Informational Displays Table.....33
- Quadrant 2: Text and Warning Messages.....39
- Quadrant 2: Text and Warning Messages Table.....39
- Quadrant 3: Display Messages Table.....45
- Quadrant 4: Transmission Gear Displays.....46
- Quadrant 4: Transmission Gear Indications Table.....46

R

- Raising the Hood.....178
- Rear Axle – Inspection and Lubrication.....194
- Reflective Triangle.....171
- Chassis Fuse / Circuit Breaker Chart.....171
- Power Relays Table.....173
- Regeneration.....222
- Regeneration Inhibit Switch.....141
- Removal.....232
- Reporting Safety Defects.....5
- Canadian Registered Vehicles.....5
- U.S. Registered Vehicles.....5
- Reserve Fuel.....130
- Restarting After Running Out of Fuel.....130, 142
- Retracting and Stowing Operation.....167
- Right Console Switch Panel.....69
- Rocker Switches and Their Functions.....69
- Rocker Switches and Their Functions.....63, 69
- Roof Vent / Hatch.....91
- Rotation.....226
- Rotation Is Advisable.....226
- Tire Replacement.....227
- Rotation Is Advisable.....226

S

- Safety Recalls and Authorized Field Changes.....5
- Scheduled Maintenance.....204
- Seat Base Bolts Table.....256
- Seat Belt Cutter.....99
- Seat Belt Tether.....97
- Tether Adjuster Procedure.....97

S (CONT.)

Seat Height Adjustment.....	94
Selective Catalytic Reduction System (If Equipped).....	131
DEF Contamination or SCR System Fault.....	134
DEF Tank.....	132
Diesel Exhaust Fluid.....	131
Indicators about DEF Quality Problem (For Vehicles Equipped with Cummins® B Engines) Table.....	135
Indicators about Low DEF Level (For Vehicles Equipped with Cummins® B Engines) Table.....	133
Introduction.....	131
Low DEF Level.....	132
Warnings of SCR System Fault (For Vehicles Equipped with Cummins® B Engines) Table.....	136
Self Diagnostics.....	128
Service Information.....	257
Signaling for a Turn.....	76
SmartTrac™ Hydraulic Brake Booster System (If Equipped).....	145
SmartTrac™ Hydraulic Brakes - Fluid Precautions.....	201
SmartTrac™ Hydraulic Brakes (If Equipped).....	199
Brake Inspection and Adjustment.....	199
Brake Lines, Hoses, and Fittings.....	199
Fluid Precautions.....	199
Snooze Mode.....	86
Split-System Feature.....	146
Stability Control Systems – Bendix® Electronic Stability Program (ESP).....	159
Standard Allison 1000 PTS Transmission.....	160
Starting Bus in Motion.....	166
Starting Bus in Motion With Transmission Shift / Wheelchair Lift Interlocks.....	167
Starting Procedures.....	125
Starting the Engine.....	125

S (CONT.)

<i>Starting Procedures (cont.)</i>	
Automatic Transmission Starter Interlock.....	126
Starting the Engine.....	125
Automatic Transmission Starter Interlock.....	126
Stationary Pre-Set Speed Control (12VXU).....	61
Stationary Variable Speed Control (12VXT).....	61
Steering.....	218
General.....	218
Lubrication Points.....	219
Power Steering.....	220
Tightening Steering Intermediate Shaft Joint Bolts.....	219
Steering Column Bolts Torque Chart Table.....	254
Steering Wheel and Column.....	58
Adjustable Tilt Steering Column.....	62
Cruise Control.....	60
Basic Functions of Steering Wheel Controls.....	60
Mobile Variable Speed Control (12VXV).....	62
Operational Procedures.....	60
Stationary Pre-Set Speed Control (12VXU).....	61
Stationary Variable Speed Control (12VXT).....	61
Throttle.....	61
Horn.....	59
Steering Wheel Controls.....	58
Steering Wheel Controls (Optional).....	59
Steering Wheel Controls.....	58
Steering Wheel Controls (Optional).....	59
Storage Duration – One Month or Less.....	3
Storage Duration–Over One Month.....	4
Strobe Light.....	78
Supplemental Federal Emission Control System Maintenance, Repair, and Replacement.....	8
Supplemental Federal Emission Control System Warranty.....	7

S (CONT.)

Supplemental Federal Emission Control System Warranty (cont.)

- Additional Components Covered.....8
- GHG Emission Control System Warranty Period.....7
- Supplemental Federal Emission Control System Maintenance, Repair, and Replacement.....8
- Supporting Your Vehicle for Service.....189
- Surface Cleaning.....183
 - ABS / Plastic.....184
 - General Cleaning, All Surface Types.....183
 - Glass.....184
- Suspension (Air and Steel Springs).....218
- Switch Location.....78
- Switching-Off Sequence.....121
- System Activation.....85
- System Deactivation.....85
- System Function.....85
- System Purpose.....85

T

- Tampering with Noise Control System Prohibited.....6
- Telematics Module (If Equipped).....55
- Terminal Inspection–Cleaning–Corrosion Protection.....202
- Tether Adjuster Procedure.....97
- Three-Position Door Switch.....80
- Three-Position Regeneration Inhibit Switch.....142
- Throttle.....61
- Tightening Steering Intermediate Shaft Joint Bolts.....219
- Tilt Hood.....178
 - Lowering the Hood.....179
 - Raising the Hood.....178
- Tire and Rim Combinations.....245

T (CONT.)

Tire and Rim Combinations (cont.)

- Approved Tire and Wheel Combinations Table.....245
- Tire Maintenance.....224
 - Checking Inflation.....224
 - Underinflation.....225
- Tire Replacement.....227
- Tire Warnings.....223
- Tires.....223
 - Dual Tires Matching.....226
 - Dual Tires Mixing.....226
 - Inspection.....225
 - Loads.....225
 - Rotation.....226
 - Rotation Is Advisable.....226
 - Tire Replacement.....227
 - Tire Maintenance.....224
 - Checking Inflation.....224
 - Underinflation.....225
 - Tire Warnings.....223
 - Use of Tire Chains.....228
 - Wear.....227
 - Irregular Wear.....227
 - Wheel and Tire Balancing.....227
- To Manually Apply the Parking Brake.....147
- To Manually Release The Parking Brake.....147
- Torque Specification Charts.....254
 - Axle U-Bolt Nut Torque Chart Table.....255
 - Disc Wheels Torque Chart Table.....254
 - Seat Base Bolts Table.....256
 - Steering Column Bolts Torque Chart Table.....254
 - Wiper Arm Torque Chart Table.....256
- Towing Instructions.....180

Index

T (CONT.)

<i>Towing Instructions (cont.)</i>	
Towing Preparation: Air Parking Brakes.....	181
Towing Vehicle With Front Wheels Suspended.....	181
Towing Vehicles With Rear Wheels Suspended.....	181
Towing Preparation: Air Parking Brakes.....	181
Towing Vehicle With Front Wheels Suspended.....	181
Towing Vehicles With Rear Wheels Suspended.....	181
Track Seat Mounting Seat Type Specific.....	113
Traction Control.....	154
Traffic Warning System.....	81
Eight-Lamp AMBER and RED Warning Lights.....	81
Electronic Safety Messages.....	81
Optional Rocker Switches.....	82
WIG WAG Warning System.....	83
Transmission.....	222
Transmission Fluid Level.....	222
Transmission Fluid Level.....	222
Transmission Table.....	244
Transmission, Parking Brake, and Ignition Switch Panel.....	67
Troubleshooting.....	207
Turn Signal.....	58
Turn Signal Switch.....	76
HIGH / LOW Beam.....	77
Lane Change.....	77
Signaling for a Turn.....	76
Turning OFF the Engine.....	144
Two-Position Door Switch.....	79
Two-Position Regeneration Inhibit Switch.....	142

U

U.S. Registered Vehicles.....	5
Ultra-Low Sulfur Diesel Fuel Requirements.....	128

U (CONT.)

Unacceptable Fuel Blends.....	128
Unbuckling.....	103
Underhood and Fluid Checks.....	16
Auxiliary Fuel-Fired Heater System Table.....	21
Emergency Exits and Equipment Table.....	21
Integrated Air Conditioning System (IC Air) Table.....	20
Interior Visual and Operational Checks Table.....	18
Underhood and Fluid Checks Table.....	17
Underhood and Fluid Checks Table.....	17
Underinflation.....	225
Unit Refill Capacities.....	243
Air Conditioner Refrigerant.....	243
Cooling System Refill Capacities.....	243
Diesel Exhaust Fluid Tank.....	244
Engine Crankcase.....	244
Unloading Students With Engine OFF.....	87
Upholstery Care.....	184
Use of Tire Chains.....	228
User Switches.....	52
Using Air Brakes.....	149
Using the Air Parking Brake.....	149

V

Vandal Locks.....	91
Entrance Door Lock (If Equipped).....	92
Vandal Locks with Starter Interlock (If Equipped).....	91
Vandal Locks with Starter Interlock (If Equipped).....	91
Vehicle Identification.....	1
Vehicle Storage Instructions.....	3
Diesel Exhaust Fluid (DEF) Storage.....	4
Storage Duration – One Month or Less.....	3
Storage Duration–Over One Month.....	4

V (CONT.)

Vehicle Telematics (If Equipped).....55
 Overview.....55
 Telematics Module (If Equipped).....55
 Vertical Emergency Exit Window.....90

W

Warning Indicators.....25, 144
 Warning Message Table.....45
 Warning Messages.....45
 Warnings of SCR System Fault (For Vehicles Equipped with
 Cummins® B Engines) Table.....136
 Waxing or Polishing Vehicles.....186
 Wear.....227
 Irregular Wear.....227
 Wheel and Tire Balancing.....227
 Wheel and Wheel Nut Maintenance and Installation.....228
 Hub-Piloted Wheel Installation Procedures.....229
 Wheel Nut Torque Maintenance.....229
 Wheel Nut Torque Maintenance.....229
 Wheelchair Lift Alarm.....88
 Wheelchair Lift Extension Operation.....151, 166
 Wheelchair Lift Interlocks – Extending.....87
 Wheelchair Lift Interlocks–Retracting and Stowing.....88
 Wheelchair Lift Operation.....87
 Wheelchair Lift Alarm.....88
 Wheelchair Lift Interlocks – Extending.....87

W (CONT.)

Wheelchair Lift Operation (cont.)
 Wheelchair Lift Interlocks–Retracting and Stowing.....88
 Wheels.....228
 Wheel and Wheel Nut Maintenance and Installation.....228
 Hub-Piloted Wheel Installation Procedures.....229
 Wheel Nut Torque Maintenance.....229
 WIG WAG Warning System.....83
 Windshield Washer.....57
 Windshield Wiper.....231
 Wiper Blade Assembly Replacement.....231
 Windshield Wiper / Washer System.....57
 Windshield Washer.....57
 Windshield Wiper Speed Control.....57
 Wiper Blade Speed.....57
 Windshield Wiper Speed Control.....57
 Winter Fronts.....143
 Wiper Arm Removal / Replacement.....231
 Installation.....232
 Maintenance Intervals.....233
 Lubrication and Maintenance Interval Chart Notes.....234
 Lubrication and Maintenance Interval Chart Symbols
 Key.....234
 Removal.....232
 Wiper Arm Torque Chart Table.....256
 Wiper Blade Assembly Replacement.....231
 Wiper Blade Speed.....57