

Technical Service Information

MAXXFORCE®

ADVANCED DIESEL POWER

TSI-09-12-11

Date: February 2010
Subject File: Engine

Subject: Injection Pressure Regulator (IPR) Seals Kit

Engine Family: International® MaxxForce® DT, 9, and 10 (2007 through 2009 MY)

Description

IPR seals kit (1889027C91) has been released to replace damaged or eroded seals. This kit is used only on revised IPR valves. To determine if the engine was updated with a revised IPR valve (1832232C94), remove the IPR valve and measure the width of the middle O-ring groove. The O-ring groove on an old IPR valve (1832232C93) will measure 3.5 mm (0.1378 in). If the IPR valve has not been updated and has seal or other problems, the valve must be replaced.

For removal and installation procedures, see EGES-335 *Engine Service Manual*.

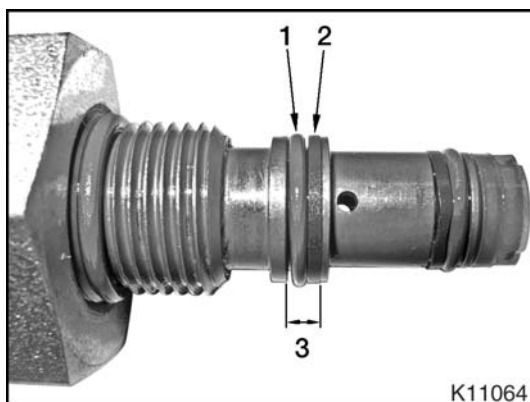

Figure 1 IPR valve (old)

1. O-ring seal
2. Middle back-up ring seal
3. 3.5 mm (0.1378 in)

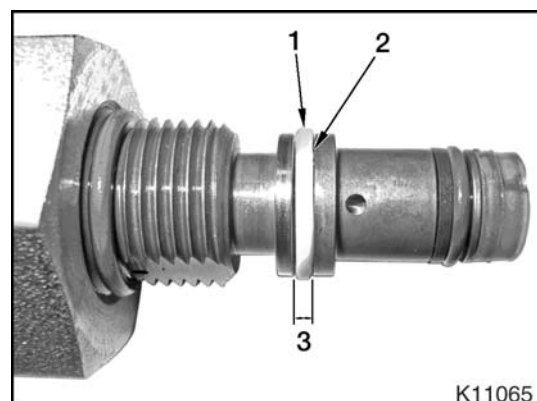

Figure 2 IPR valve (revised)

1. PTFE OE profile seal
2. O-ring seal #13 [10.82 mm (0.43 in) I.D.] (located under PTFE seal)
3. 2.14 mm (0.0843 in)